

# MASTER THESIS

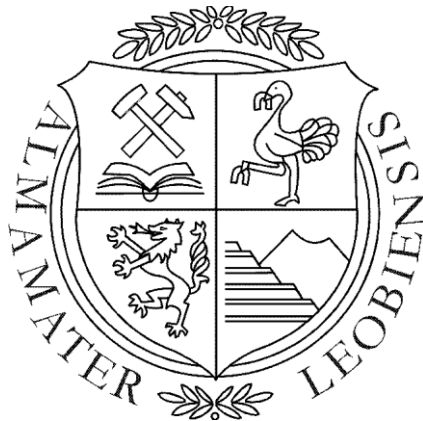

Department of Drilling and Completion Engineering  
Mining University of Leoben

**By:**

B.Sc. Philipp Fischer

**Under the supervision of:**

Prof. Dr. Gerhard Thonhauser

M.Sc. Andre EL-Alfy

Leoben, Oktober 2010

# **Cementation Optimization of Solid Expandable Liners**

I declare in lieu of oath, that I wrote this Thesis and performed the associated research myself using only literature cited in this volume.

This Master Thesis is dedicated to my whole family, love and friends. All my success is linked to their support and faith in me.

## **Acknowledgements**

First of all I would like to express my deepest gratitude to my parents Christine and Werner and my sisters Jeannine and Magdalena. They have always supported me on my path through life and my studies at the Alma Mater Leobensis.

Further I would like to thank Anna for her love and patience throughout the time I have written this thesis.

# Table of Contents

|  |           |
|--|-----------|
| <b>Abstract</b> .....                                    | <b>1</b>  |
| <b>SET - Technological Overview</b> .....                | <b>3</b>  |
| <b>SET Underlying Principles</b> .....                   | <b>3</b>  |
| SET - basic processes and material properties .....      | 3         |
| Underlying Process - cold forming of metal .....         | 3         |
| Process determining material properties .....            | 4         |
| Young's Modulus.....                                     | 4         |
| Strain hardening coefficient (n) .....                   | 5         |
| Ductility .....  | 6         |
| Spring back - Elastic recovery .....                     | 7         |
| The yield poin/strengtht .....                           | 8         |
| Practical Process - Solid tubular expansion .....        | 8         |
| The stress controlled expansion .....                    | 8         |
| Strain controlled expansion .....                        | 9         |
| SETs post expansion properties and capabilities .....    | 9         |
| Effect of expansion on pipe properties.....              | 9         |
| Geometry.....  | 9         |
| Material: .....  | 10        |
| Effect of expansion on pipe capabilities .....           | 12        |
| Collapse resistance .....                                | 12        |
| Burst resistance .....                                   | 13        |
| Tensile resistance .....                                 | 14        |
| Environmental resistance .....                           | 14        |
| Basic design considerations.....                         | 14        |
| Expansion pressure/pulling-pushing force .....           | 14        |
| Expansion cone design.....                               | 16        |
| Expansion cone angle.....                                | 16        |
| Operation mode .....                                     | 16        |
| Interfacial friction .....                               | 16        |
| Expansion rate.....                                      | 16        |
| <b>SET in drilling – benefits and applications</b> ..... | <b>18</b> |
| Planed Installation .....                                | 19        |
| Contingency Installation .....                           | 23        |
| Application designs .....                                | 24        |
| OHL/OHC .....  | 24        |
| CHL/CHC .....  | 24        |
| <b>Expandable Open-Hole Liner System</b> .....           | <b>25</b> |
| General-Aspects .....                                    | 25        |
| Top-down Expansion (Baker-Hughes) .....                  | 27        |
| Introduction.....  | 27        |
| System major components.....                             | 27        |
| Expansion Tool .....                                     | 27        |
| Running Tool.....  | 28        |
| Retrievable Guide Shoe.....                              | 29        |
| Recess Shoe .....  | 29        |
| System Description .....                                 | 32        |
| Operational sequence.....                                | 32        |

|  |           |
|--|-----------|
| System features.....                             | 34        |
| System Performance.....                          | 34        |
| Bottom -Up Expansion (Enventure).....            | 34        |
| Introduction.....                                | 34        |
| System major components.....                     | 35        |
| Launcher .....                                   | 35        |
| Nose assembly.....                               | 35        |
| Expansion assembly .....                         | 35        |
| System description.....                          | 36        |
| Operational sequence.....                        | 36        |
| System features.....                             | 37        |
| System Performance.....                          | 38        |
| <b>Cementation of SET .....</b>                  | <b>39</b> |
| <b>SET cementation techniques .....</b>          | <b>39</b> |
| Post-expansion cement placement .....            | 39        |
| System major components.....                     | 39        |
| Contingency Recess Shoe .....                    | 39        |
| Cement retainer .....                            | 40        |
| Step in/stinger cementation String .....         | 40        |
| Cement placement procedure .....                 | 41        |
| System features.....                             | 42        |
| Pre-expansion cement placement.....              | 43        |
| System major components:.....                    | 43        |
| Work string .....                                | 43        |
| Launcher .....                                   | 43        |
| Cement placement procedure .....                 | 43        |
| System features.....                             | 44        |
| <b>Cementation Optimization of SET .....</b>     | <b>46</b> |
| Well preparation and conditioning.....           | 46        |
| Open-Hole Quality .....                          | 46        |
| Solid removal and mud conditioning.....          | 46        |
| SET centralization.....                          | 47        |
| Classification .....                             | 47        |
| Centralization matter.....                       | 48        |
| Centralizer designs .....                        | 49        |
| SET centralizer adaption .....                   | 50        |
| The close tolerance expandable centralizer ..... | 50        |
| Rigid Solid Centralizer.....                     | 51        |
| Down-Hole Activated Centralizers .....           | 52        |
| Alternative strategies.....                      | 52        |
| Cement slurry design and preparation.....        | 53        |
| Governing Parameters.....                        | 53        |
| Thickening Time.....                             | 53        |
| Static Gel Strength.....                         | 54        |
| Compressive Strength .....                       | 55        |
| Fluid Loss.....                                  | 55        |
| Slurry Stability.....                            | 56        |
| Cement Testing .....                             | 56        |
| Cement Preparation.....                          | 59        |
| Cement placement optimization .....              | 59        |
| Fluid design.....                                | 59        |
| Washer.....                                      | 59        |
| Spacer .....                                     | 60        |
| Slurry .....                                     | 60        |

|   |            |
|---|------------|
| <b>Standoff Simulation of SEL Strings.....</b>            | <b>62</b>  |
| <b>SEL Operation Range base on Centralization .....</b>   | <b>62</b>  |
| Simulation - Objectives .....                             | 62         |
| Simulation - Base Case .....                              | 63         |
| Wellbore .....  | 63         |
| SEL-String .....  | 68         |
| Enventure SEL System.....                                 | 68         |
| Baker SEL System.....                                     | 70         |
| Calculation Approach.....                                 | 71         |
| Centralized SEL Pipe .....                                | 72         |
| Non Centralized SEL Pipes .....                           | 76         |
| Software Limitations .....                                | 79         |
| Results and Conclusion .....                              | 80         |
| Enventure SEL System.....                                 | 80         |
| Baker SEL System .....                                    | 81         |
| <b>Standoff Simulation – Real World Data Well A .....</b> | <b>82</b>  |
| Simulation.....   | 83         |
| Base case .....   | 83         |
| SEL-String .....  | 86         |
| Enventure SEL System.....                                 | 86         |
| Baker SEL System.....                                     | 88         |
| Results and conclusion .....                              | 90         |
| Enventure System .....                                    | 90         |
| Baker System .....  | 94         |
| Well A.....   | 97         |
| <b>Discussion .....</b>                                   | <b>98</b>  |
| <b>References .....</b>                                   | <b>101</b> |
| <b>Appendix A .....</b>                                   | <b>107</b> |
| <b>List of Figures .....</b>                              | <b>107</b> |
| <b>List of Tables.....</b>                                | <b>110</b> |
| <b>List of Equations .....</b>                            | <b>111</b> |





# Abstract

Solid expandable tubular (SET) are wellbore pipes produced from steel or non-ferrous metals like titanium or aluminum, which show proper mechanical and chemical properties to withstand cold forming operations, in which their diameter is increased, while maintaining conventional pipe geometry and the capability to withstand a certain level of down-hole conditions.

The process is performed via an oversized cone, which is forced through the pipe string. Within this procedure the pipe material is predominately deformed in hoop-direction under enormous tensional load. It is deformed over the elastic limit into the plastic region, resulting in a permanent increase in pipe body diameter. As the pipe is subjected to high stress without significant heat contribution the material properties are altered, changing the pipe load capabilities.

As the conventional casing program is based on a continuous diameter reduction with each string installed, due to drift considerations, the installation of solid expandable tubular allow a diameter conservation, compared to the previous string up to 100 percent. The dissolution of the telescopic profile allows to boost the drilling reach capabilities and the economic efficiency of drilling operations.

Based on the technological concept of SET several different application designs have proved to be economically deployable as a tool in well construction. Today's most common product is the solid expandable liner (SEL). This system consists of a liner string which is expanded down hole and hung in the preliminary base casing string. Although multiple products are available only two basically different design approaches for SEL could be identified. Both designs the bottom-up and the top-down expansion are offered by marked leading service providers.

As the SEL offer a range of advantages compared to a conventional liner it also differs precisely in design, necessitating an adaption of good practice in procedures related to the installation of a liner string, such as zonal isolation. Both design approached covered in this thesis allow cementation of the SEL string, but due to their design characteristics the common practice have to be adapted. Well known practices, parameters and supporting tools, used to achieve good cement job quality, can hardly be applied, due to the changes in design and operational sequence compared to conventional liners.

Due to these restrictions a good cementation quality for SEL strings is at least a challenging goal.

Analyzing the cementation techniques, developed for the investigated SEL systems as well as the recommendations for SEL cementation, based on literature and field experience, the poor centralization capability was identified as one of the major characteristics which have to be handled.

With the appearance of the SET technology as a commercial application, the good centralization technique became obsolete. Due to the low annular clearance while running typical SET strings and the expansion of the pipe it selves, standard centralizers couldn't be applied. As the leak of centralization is known to be a negatively influence on cementation quality, a low clearance centralizer designs was required, able to join the expansion process without causing any destruction on the casing or constricting the expansion process while maintaining or generating centralization capabilities.

Within the last years the first representatives of this new generation of centralizers entered the marked. For both investigated SEL designs, the service providers offer special centralization techniques.

To quantify the impact of this new option, a simulation with marked leading software was performed. Therefore the standoff, which represents the degree of centralization, was investigated for both SEL designs with and without centralizers installed, over a range of

application parameters. As a result an operation range could be identified, across which the minimum centralization requirements are fulfilled.

Furthermore available data of a real world case have been used to investigate the standoff for an individual situation to confirm the initial simulation, which has to be based for simplification reasons on a more generalized point of view, and to optimize the application parameters for the new centralizer techniques.

# SET - Technological Overview

## SET Underlying Principles

### SET - basic processes and material properties

Solid expandable tubular (SET) are wellbore pipes produced from steel or non-ferrous metals like titanium or aluminium, which show proper mechanical and chemical properties to withstand cold forming operations in which their diameter is increased, while maintaining the capability to withstand down-hole conditions. The underlying process is the permanent deformation of the tubular under ambient temperature (Static Down-Hole Temperature - DHTS), after running the pipe to its desired destination down-hole. The process is classified as cold forming of metal, as typical DHTS is too low to contribute perceptibly to the deformation (SPE67770; SPE105704; SPE60766).

### **Underlying Process - cold forming of metal**

The process is defined as altering shape or size of metal by plastic deformation, below recrystallization temperature.

Based on an idealized point of view each metal undergoes several stages during continuous deformation, visualized by the stress-strain curve (Figure 01). So if typical oil field pipe material (steel based alloy; aluminum; titan) is subjected to an external increasing tensional load, the initial stage of deformation ranges within the elastic region. Loading and unloading to any point of this area does not cause permanent deformation. The slope of this initial for most metals linear strain response to the induced stress is the Young's Modulus.

As the stress exceeds the Yield Strength the metal deforms plastically. Metal which is stressed beyond this stress limit into the plastic region will be deformed uniformly and after unloading a large portion of the deformation remains permanently. While following the deformation curve within the plastic region, the course implements a hardening with each unique increment of deformation.

Aligned with this increase in load required to deform the metal for a well defined increment, the geometry of any kind of object subjected to a unidirectional tensional stress, changes. The cross-sectional area, along which the applied load is distributed, is continuously reduced. This effect is called geometrical softening (Figure 01).

If the balance between the increasing softening and the constant hardening effect is reached, a load maximum can be observed (tensile strength) and deformation continues under decreasing load. As total material homogeneity can never be achieved, some weaker areas of the material reach this point of balance slightly earlier, causing a fastened deformation across this section. With the increase in deformation in portions of the material, the point of balance between the hardening and the softening effect can't be reached in the rest of the material, where no more deformation can be encountered. This non-uniform kind of deformation is called necking and represents the initial stage before the material fails completely (ultimate/fracture strength).

So the plastic region can be subdivided into the uniform and the post uniform deformation area on left and right hand side of the tensile strength and it is bounded by yield and ultimate strength.

The expansion process of the SET technology is governed by the tensional stress and strain in circumferential direction. As the most essential capability of SETs is to achieve a constant

pipe diameter and wall thickness, to provide uniform properties across the whole length of the string, the expansion process is limited to the uniform plastic deformation region.

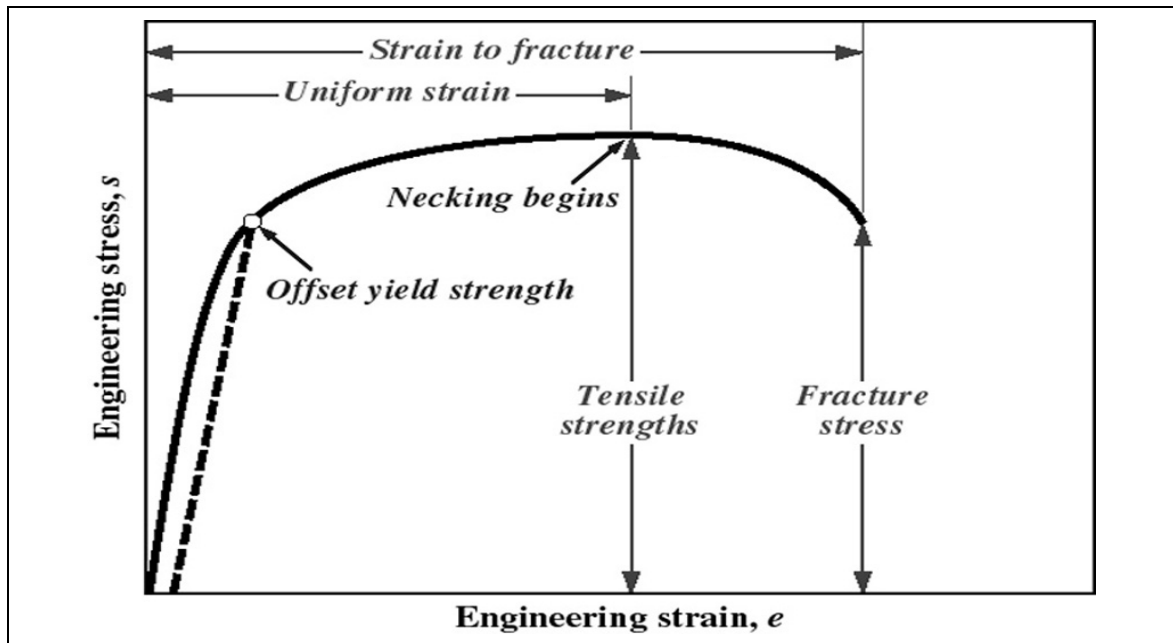

Figure 01: Idealized Stress-Strain curve of metal under axial load – SPE 60766, R.B. Stewart et.al

### Process determining material properties

#### Young's Modulus

Young's Modulus is defined as the ratio of stress over the strain in the elastic deformation region or as the slope of the straight initial response in the material stress strain curve (Equation 06). It is a measure of the stiffness adverse elastic deformation.

|  |  |
|--|--|
| $E = \frac{\sigma}{\epsilon} = \frac{F/A_0}{\Delta L/L_0}$ | ε..... Engineering strain  |
|  | σ..... Engineering stress  |
|  | F..... Applied force   |
|  | A o..... Initial cross-sectional area perpendicular to the force direction |
|  | Δ L..... Length variation in force direction                               |
|  | L o..... Initial length in force direction                                 |

Equation 06: Young's Modulus

### Strain hardening coefficient (n)

As already mentioned, if the yield strength is exceeded and plastic deformation can be encountered, a hardening process can be observed. Each further strain increment requires an increase in stress until the ultimate strength is reached.

To quantify this effect the true stress (Cauchy – Equation 01), which is a parameter eliminating the geometric weakening effect, as it is defined as the load over the current cross-sectional area, has to be contemplated. If the logarithm of the true stress is plotted over the logarithm of strain most steels show a straight stress-strain curve. The slope of this curve is the so called hardening coefficient “n” (Figure 03). If the engineering strain at ultimate tensile stress ( $\epsilon_{uts}$ ), where necking starts to occur, is known (inflection point) the factor “n” can be easily calculated by Equation 04.

The strain hardening coefficient represents one of the best measures for the formability of metals as outlined in by R.B. Stewart et. al. (SPE60766), and allows material specific prediction of the pipe expandability. In general it can be mentioned that materials with high “n” values show higher uniform plastic formability and therefore higher expandability (Table 01).

| <b>Material</b>                      | <b>Strain Hardening Coefficient [n]</b> | <b>Theoretical max. Expansion [%]</b> |
|--------------------------------------|---|---------------------------------------|
| <i>Low-carbon steel</i>              | 0,2                                     | 33,2                                  |
| <i>Interstitial-free steel</i>       | 0,3                                     | 52,5                                  |
| <i>High-strength low-alloy steel</i> | 0,18                                    | 29,6                                  |
| <i>Dual-phase (TRIP) steel</i>       | 0,25                                    | 42,6                                  |
| <i>Austenitic stainless steel</i>    | 0,5                                     | 97,3                                  |
| <i>Ferritic stainless steel</i>      | 0,23                                    | 38,7                                  |
| <i>Duplex stainless steel</i>        | 0,15                                    | 24,3                                  |

**Table 01:** Impact of Strain Hardening Coefficient “n” onto expansion ration of different steel materials analytically calculated - SPE 60766, R.B. Stewart et.al

|   |  |
|---|--|
| $\epsilon_{eng} = \frac{\Delta L}{L_{ini}}$           | <p><math>\epsilon_{eng}</math>..... Engineering strain</p> <p><math>\Delta L</math>..... Length variation in force direction</p> <p><math>L_{ini}</math>..... Initial length in force direction</p>  |
| $\sigma_{eng} = \frac{F}{A_{ini}}$                    | <p><math>\sigma_{eng}</math>..... Engineering stress</p> <p><math>F</math>..... Applied force</p> <p><math>A_{ini}</math>..... Initial cross-sectional area perpendicular to the force direction</p> |
| $\sigma_{true} = (1 + \epsilon_{eng}) * \sigma_{eng}$ | <p><math>\sigma_{true}</math>..... True (Cauchy) stress</p> <p><math>\epsilon_{eng}</math>..... Engineering strain</p> <p><math>\sigma_{eng}</math>..... Engineering stress</p>                      |
| $n = \ln(1 + \epsilon_{UTS})$                         | <p><math>n</math>..... Strain hardening coefficient</p> <p><math>\epsilon_{uts}</math>..... Engineering strain at ultimate tensile strength</p>  |

**Equation 01-04:** Evaluation process of Strain hardening Coefficient “n” based on a tensile strength test

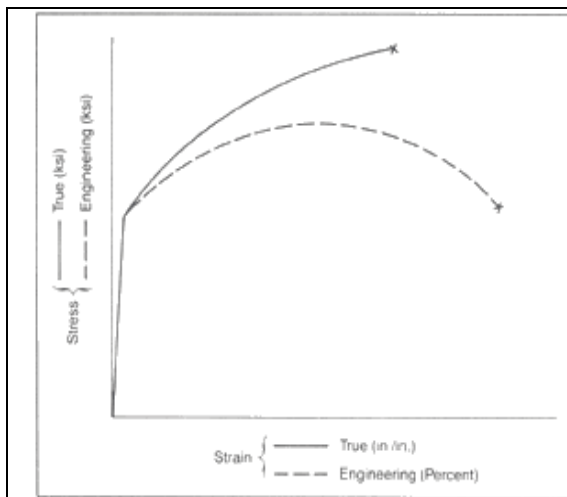

**Figure 02:** True and Engineering Stress-Strain curve - American Iron and Steel Institute

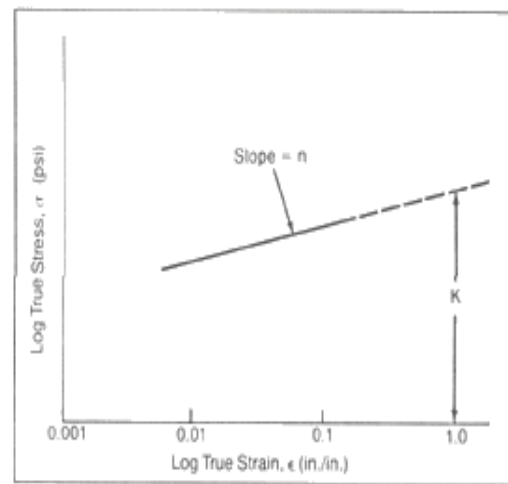
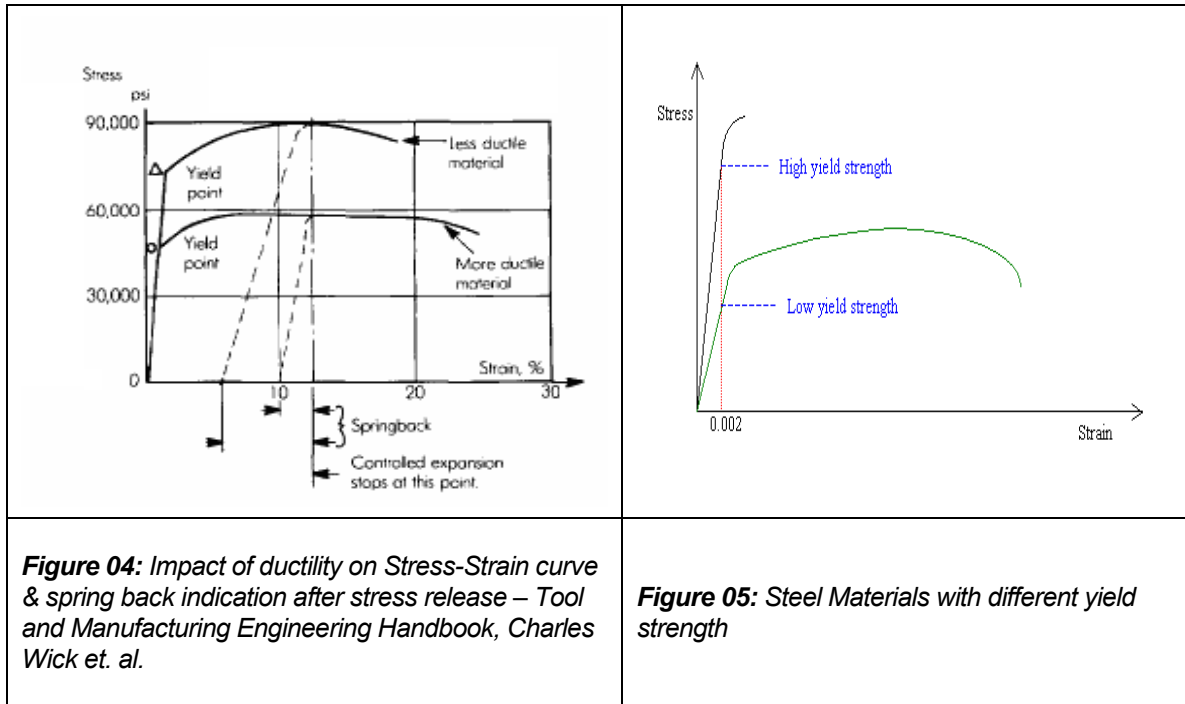

**Figure 03:** True Stress-Strain curve with a LOG-LOG scale - American Iron and Steel Institute

### Ductility

Ductility of a material is defined as the extent to which the material can sustain plastic deformation without rupturing. A high ductile material show large uniform deformation before

fractures start to occur and is therefore preferable to achieve high expansion ratios (Figure 04). The lack of ductility is termed brittleness. In the stress-strain diagram the ductility is indicated by the length of the curve within the plastic region (yield point-ultimate strength). Ductility is strongly related to the “n” value and therefore also an important indication for expandability.



Spring back - Elastic recovery

Spring back or elastic recovery is the non-permanent part of the deformation. Each material deformed into the plastic region will lose some strain after unloading due to a residue of elastic behaviour even in the plastic region. The spring back predominately depends on the yield strength and the Young’s modulus. As lower the yield strength and as higher Young’s modulus as lower the spring back effect observed after deformation. For the expansion of pipes a good rule of thumb to evaluate the diameter decrease after unloading is given by Equation 05. Today most SET materials and operations are optimized to cover this effect completely (SPE111742).

|                                |   |
|--------------------------------|---|
| $\Delta D = D * \frac{Y_s}{E}$ | <p><math>\Delta D</math>..... Diameter decrease after stress release</p> <p><math>D</math>..... Diameter under max. stress load</p> <p><math>Y_s</math>..... Material Yield Strength</p> <p><math>E</math>..... Young’s Modulus</p> |
|--------------------------------|---|

**Equation 05:** Rule of thumb for the evaluation of spring back after circumferential expansion



The yield poin/strengtht

The yield poin/strengtht represents the boundary between the elastic and plastic region. So the yield stress at the yield point has to be exceeded to cause permanent deformation (Figure 05). As a clear yield point often cannot be observed. The yield point for ferrous metals can be defined to be a strain of 0,5 [%] with the related yield strength or a strain offset to the modulus slope line. The stress at yield point is an essential property classifying the resistance against initialization of permanent deformation. Furthermore most materials show a decrease in ductility (formability) with an increase of yield strength. So it can be gathered that lower yield strength is favourable for the expansion process. But it has to be kept in mind that the post expansion capability of the pipe to withstand unintentional deformation due to external, internal pressure and tensional load also depend on the yield strength. A pipe material with too low yield strength would result in a pipe unable to withstand the typical down-hole conditions.

As a result a good compromise between yield strength and ductility has to be found for SETs. Therefore SET providers have developed, in conjunction with steel manufactures, special materials aimed to meet the objectives of materials used for expandable technology. To achieve proper material characteristics, metal chemistry and treatment procedures have been adapted. Detailed information about the material characteristics and treatment procedures havened been published by the providers such as Baker Oil Tools or Enventure due to confidentiality reasons.

**Practical Process - Solid tubular expansion**

The stress controlled expansion

The stress controlled expansion or expansion via internal pressure is a simple, but limited way of cold forming cylindrical tubular members. To increase the diameter the internal pressure has to exceed the yield pressure, which represents the pressure differential required to excess the pipe material yield strength. With increasing pressure, the expansion process would continue until pressure reaches the burst rupture pressure at which the pipe would fail. The strain hardening index is a measure of formability of metals which allows the evaluation of tubular expansion ratios. Based on the material properties and the specific stress situation caused by the pure pressure technique the expansion ratios achievable with stress inducement are below the industry requirements. Furthermore the process shows a high sensitivity to material imperfections causing unpredictable results. The Equation 07 (SPE60766) is an empirical equation to evaluate expansion capability for pressure induced forming process.

|  |  |
|--|--|
| $\delta_{MAX} [pct] = \frac{\Delta d}{d} = \left[ e^{\frac{n}{2}} - 1 \right] * 100$ | <p>δmax.....Maximum expansion ratio before failure</p> <p>Δd..... Diameter change</p> <p>d ..... Unexpanded pipe diameter</p> <p>n..... Strain hardening coefficient</p> |
|--|--|

**Equation 07:** Empirical equation to evaluate expansion capability for pressure induced forming process - SPE60766, R.B. Stewart et.al

Strain controlled expansion

The strain controlled expansion is based on pushing or pulling a conical shaped mandrel with larger outer diameter than the initial internal tube diameter through the pipe. The expansion cone can be pulled or pushed mechanically and or hydraulically while it has to be supported from one side (back end or front end) leading to an expansion process causing either tension in the expanded pipe section or compression in the un-expanded section.

The tube is expanded by the cone in three stages: an up-banding slightly in front of the device, the expansion across the conical surface of the mandrel and the back-bending over the edge of the cone. This kind of expansion process shows a different stress and strain pattern within the pipe, compared to the stress controlled expansion. Based on experimental observations the maximum expansion ratio of the strain controlled process can be evaluated by Equation 08. This rule of thumb shows that oil field pipes reach, related to the available materials, accurate diameter increases.

|   |   |
|---|---|
| $\delta_{MAX} [pct] = \frac{\Delta d}{d} \approx \frac{3}{2} * [e^n - 1] * 100$ | <p>δmax..... Maximum expansion ratio before failure</p> <p>Δd.....Diameter change</p> <p>d ..... Unexpanded pipe diameter</p> <p>n.....Strain hardening coefficient</p> |
|---|---|

**Equation 08:** Empirical equation to evaluate expansion capability for strain controlled expansion process- SPE60766, R.B. Stewart et.al

Due to the higher achievable expansion ratios the strain controlled process is the most commonly industrial utilized solution. The higher expandability can be related to the favorable stress pattern induced by the cone forced through the pipe to increase the diameter.

**SETs post expansion properties and capabilities**

**Effect of expansion on pipe properties**

Geometry

The first and most obvious changes caused by the expansion process are the changes in geometry. Depending on the expansion ratio the diameter of the pipe increases. The nominal expansion rate of the SET system is related to the inner diameter as the outer diameter always shows an increase slightly lower than the nominal rate.

This phenomenon can be related to the law of mass conservation. The increase in diameter and the related additional material requirement in hoop direction are balanced by shrinkage in

radial and axial direction. So each pipe which is expanded will shrink in wall thickness and or in length.

The balance and degree of the changes in radial and axial geometry strongly depend on system and operational parameters such as expansion-pressure, -force, -speed, -type, cone angle and pipe axial radial clearance as well as material properties. To predict the shrinkage of OCTG strings in radial and axial direction after expansion intensive physical tests and numerical simulations had to be performed for each system and pipe in use. As the operational parameters are hard to predict, and most commonly inhomogeneous, the change in wall thickness and string length after expansion, are preliminary hard to evaluate. Predictions have to be taken with caution.

Another geometrical effect, which has to be taken under consideration, is the intensifying of thickness eccentricity and or marking on the pipes during expansion. The thickness eccentricity is defined as deviation from average thickness in percent caused by the manufacturing process while marking might occur during transport and handling of the pipe. Along these imperfections and lower thickness areas the material develops concentrated stress risers during the expansion process. Higher stress level results in larger post expansion reduction in thickness and therefore an increase in eccentricity. This effect might even lead to a located exceeding of the ultimate strength and the induction of micro cracks (SPE 120193).

The ovality is another geometric irregularity, which is within a certain range, an acceptable side effect of the manufacturing process of steel pipes. The ovality was long time assumed to be reduced due to expansion, as the very accurately manufactured expansion cone and the flow of the material should equalize the normal pipe ovalization. But several experiments (SPE 120193) have shown an increase in ovality after expansion, which might be related to the gap between cone and inner pipe surface, thus the cone cannot accurately print its geometry in the pipe.

The fact that the volitional changes in geometry often do not follow the predetermined parameters which is intensified by unavoidable imperfections due to the manufacturing process, a good operational planning and execution of the process as well as accurate manufacturing control of the pre-expanded pipe is essential.

### Material:

The cold working of steel changes the basic material properties of pipes. Pipe material tests after expansion, based on sampling according to the common specifications in the circumferential and axial direction, for tension and compression showed the following results.

The first and most important observation is that the expansion (pre-straining) causes a hardening of the material. So the Yield strength of the material is increased as long as the pipe is loaded in the same direction as the pre-straining.

This effect is also known as isotropic hardening (Figure 02). The prevailing load in the pipe during the expansion process is tension in circumferential direction and with a lower magnitude compression in the axial direction. The loading in radial direction is not specified and hardly tested as it doesn't show significant influence on the casing capabilities.

Pipe expansion also intensifies anisotropy in material behaviour, causing higher Yield Strength in circumferential tension which is the initial deformation direction due to expansion but lower Yield Strength in circumferential compression which is the reverse direction of initial deformation. The increase in tensional YS can be related to the already mentioned hardening effect (isotropic hardening), while the reduction in compressional Yield Strength is most likely related to the "Bauschinger Effect" (Figure 06).

Bauschinger observed that most metal materials loaded in one direction, past the yield strength, to a certain maximum stress, unloaded and finally loaded in the reverse direction with the same magnitude of stress, will show a lower yield strength in the reverse load direction. The effect is based on stored residual stresses after plastic deformation also known

as kinematic hardening, respectively softening. This effect would explain the significant reduction in hoop compression Yield Strength of expanded pipes.

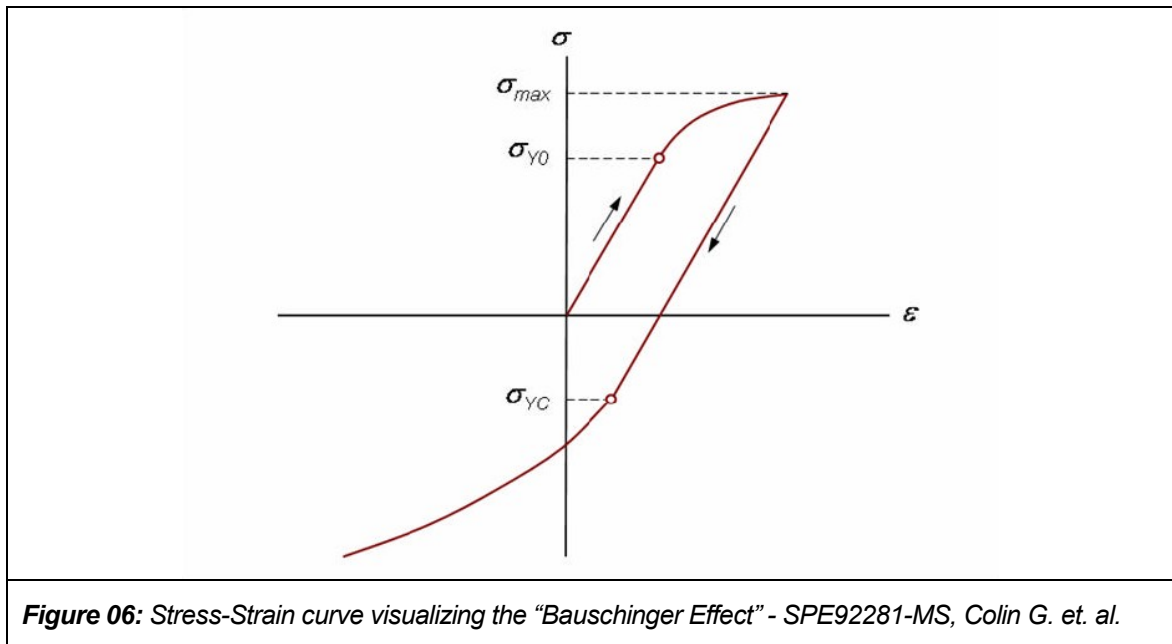

Most experiments show an increase in compressional Yield Strength in axial direction which corresponds to the hardening observation after pre straining in the same direction. The tensional Yield Strength in axial direction show a slight increase contradicting the Bauschinger Effect. A possible explanation is the lower magnitude of axial compression during the expansion process in comparison to the tensional load in circumferential direction. The tensile strength is increased in the circumferential, as well as in the axial direction. This corresponds to Yield Strength behaviour although the increase is not that strong (Table 02). And finally the uniform strain in both tensile directions is reached earlier after pre-straining.

| Axial Direction |                |                           |
|-----------------|----------------|---------------------------|
|                 | Yield Strength | Ultimate Tensile Strength |
| Tension         | constant       | slightly increasing       |
| Compression     | increasing     | -                         |
| Hoop Direction  |                |                           |
|                 | Yield Strength | Ultimate Tensile Strength |
| Tension         | increasing     | increasing                |
| Compression     | decreasing     | -                         |

**Table 02:** Quantitative indication of expansion caused changes of YS and TS in axial compression and tension direction and circumferential tensional and compressional direction – SPE111742, Fans J. Klever et. al.

As the changes in particular points described so far already indicate, the shape of the stress strain curve after expansion (pre-strain) changes completely, causing a different behavior to normal pipes of the same size, if it is subjected to external load (Figure 07). The sharp and well defined yield point which is typical for Oil Country Tubular Goods (OCTG) changes to become more rounded. The yield strength is higher, except for hoop compression, but hard to identify. However knowledge of the changes allows the adaption of existing and the creation of new methods to evaluate the down-hole capabilities of SETs.

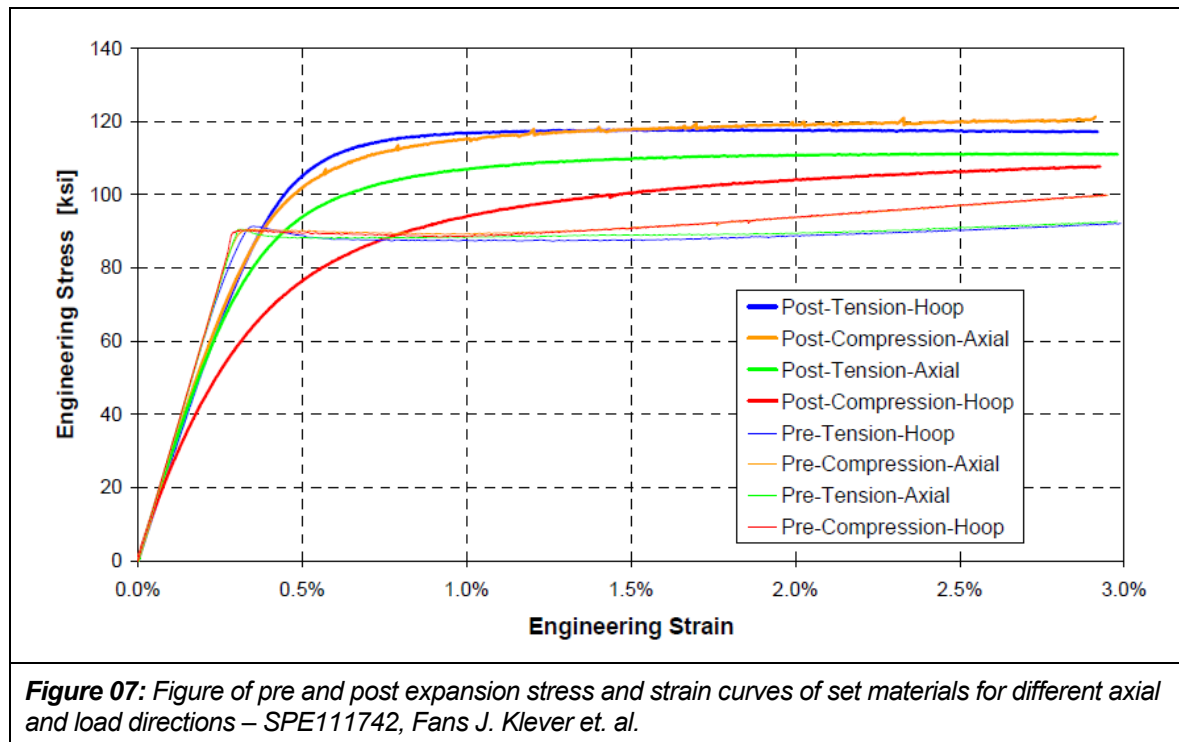

## Effect of expansion on pipe capabilities

### Collapse resistance

The collapse of a pipe due to high external pressure is a complex occurrence depending on pipe material and geometrical properties, which undergo significant changes during the expansion process. The collapse strength equations used for OCTG currently used in the oil field industry are described in API 5C3 (1994) and ISO TR 10400 (2007) standards.

All these available methods to evaluate collapse resistance are based on the standardized manufacturing and forming processes and their well known influence on the material properties as well as on the accurately controlled geometry specifications of the pipes. So far cold forming of steel under down-hole conditions and the influence on material and geometry are not considered by the standardization organizations.

The collapse of a pipe is a non uniform process, which occur in different modes depending on the geometry. It was observed that the diameter to wall thickness ratio ( $D/t$ ) can be used to relate the different pipes to the failure modes (Figure 08).

As expansion of a pipe causes an increase of the diameter and a decrease of the wall thickness (material balance/flow) this ratio is increased with expansion. Furthermore, the increase in thickness eccentricity cause by the expansion might lead to spots of inhomogeneous ( $D/t$ ) distribution along the string.

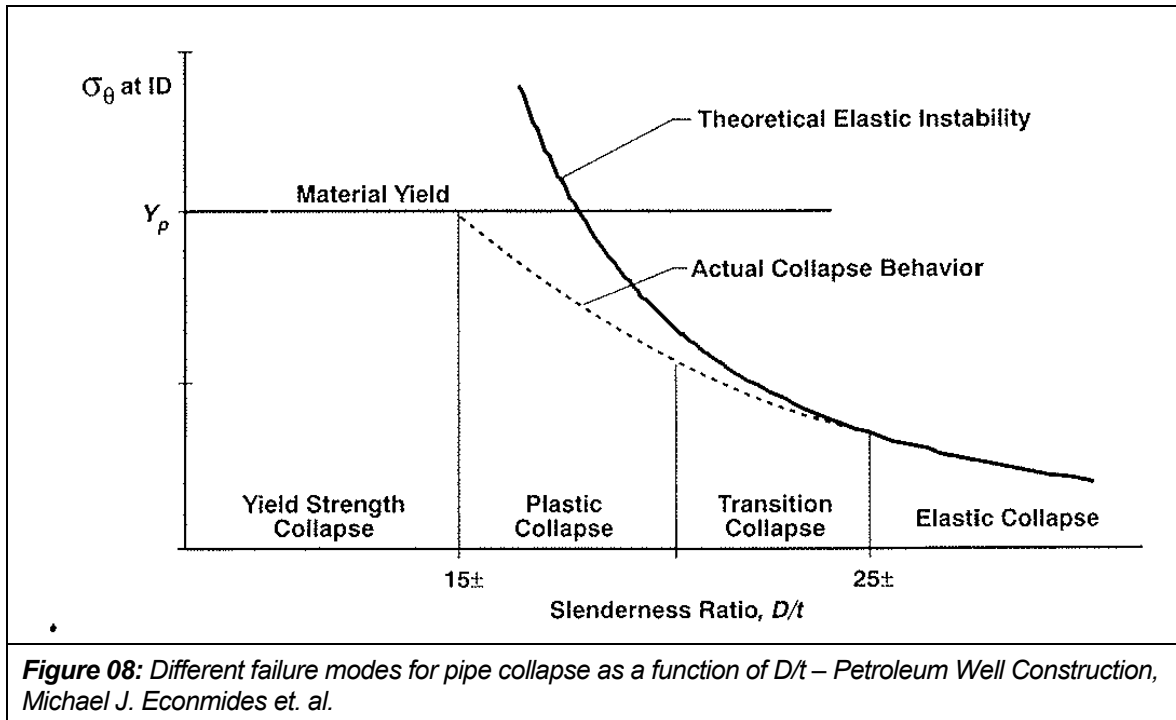

The general influence of  $D/t$  on collapse resistance can be described as followed. The higher the ratio, the lower the collapse pressure. This trend shows a higher sensitivity for low  $D/t$  values. As higher the ratio as lower the influence on the collapse pressure. So the changes in geometry due to expansion do have a negative influence on collapse resistance. Especially hardly predictable local  $D/t$  increases might exhibit high risk of collapse failure.

But nevertheless the changes in material properties have the highest impact on collapse resistance. For each failure mode in collapse, the yield strength of the material, especially in direction of circumferential compression, has enormous influence on the collapse pressure. The anisotropy in yield strength induced by the expansion effect, respectively isentropic and kinetic hardening, disqualifies the standard formulas to predict collapse resistance.

Most specifications such as American Petroleum Institute (API) or International Organization of Standardization (ISO) utilize isotropic yield strength criterions for normal OCTG, which are related to the stress-strain curves of the pre-strained material. With the changes in stress-strain curve after expansion mentioned earlier, it seems obvious that these methods can't produce an accurate output.

So several numerical studies have been performed to quantify the different influences on collapse to adapt the existing formulas (Frans J. Klever). Experimental studies on post expansion pipes showed a reduction of collapse resistance between 50 [%] and 30 [%] increasing with expansion ratio, compared to the original pipe (SPE120193).

### Burst resistance

The formulas to evaluate burst resistance currently used in oil field industry for OCTG can be found in specification ISO TR 10400 and API 5C3. Burst resistance show the same response to the geometrical changes due to expansion as collapse. The increase in diameter as well as the decrease in thickness causing a decrease in burst resistance. Probable irregularities in thickness (eccentricity) and geometry (ovalization) due to the cold working make the resistance inhomogeneous over the length and therefore hard to predict.

On the other hand the yield strength in circumferential tensional direction, which predominantly influences the burst pressure, is increased due to isotropic hardening. The yield criterion used in oil field formulas are predominately based on isotropic yield strength behaviour such as Lamé or Von Mises. The anisotropy of the material induced by the cold working and the related effects necessitates the adaptation of the equations by the use of an anisotropic yield criterion such as Hill. But the increase in burst pressure governing yield strength already indicates an increase in resistance compared to pipes with equal grade and geometry.

### Tensile resistance

As already mentioned most studies show a slight increase or an equal axial tension Yield Strength after expansion, although with the presence of Bauschinger Effect a different behavior would have been expected. The exact reason for the unanticipated characteristics is hard to evaluate due to the complex stress situation across the pipe during expansion. But never the less most studies (SPE111742) show at least an equal tensional yield and higher ultimate yield strength, so the tensile rating commonly remains unchanged.

### Environmental resistance

Several tests (SPE 110622) based on the NACE standard TM0177 have been performed to evaluate the resistance of post expanded pipes to evaluate the resistance against hydrogen induced cracking, sulphide stress cracking stress orientated hydrogen induced cracking. The test does not show any evidence of an increase in sensitivity against sour environment.

## **Basic design considerations**

### **Expansion pressure/pulling-pushing force**

To evaluate the required expansion force respectively the pressure requires to pull or push the cone through the pipe numerical simulations as well as simplified analytical solutions can be applied.

The easiest and most fundamental way to predict the operative requirements is to draw the energy balance of the expansion process. First of all, for this approach it has to be mentioned that it does not account for detailed stress and strain condition and has to be taken with caution.

Based on the law of energy conservation the work done by the cone has to equal the plastic deformation energy to deform the tubular from the initial to the final diameter plus the work required to overcome the friction along the contact surface between the expansion cone and the pipe (Equation 09).

|  |   |
|--|---|
| $\Delta W_C = \Delta E_P + \Delta W_F$ | $\Delta W_C$ ..... Work done by the cone      |
|  | $\Delta E_P$ ..... Plastic deformation energy |
|  | $\Delta W_F$ ..... Frictional resistance      |

**Equation 09: Energy balance of the pipe expansion process**

The single balance components can be evaluated via the following Equations 10-13 (SPE 92281).

|  |  |
|--|--|
| $\Delta W_C = \frac{1}{4} \pi d_c^2 p_L \Delta L$                          | $\Delta W_C$ ..... Work done by the cone               |
|  | $\Delta L$ ..... Expansion length                      |
|  | $d_c$ ..... Diameter of the cone                       |
|  | $p_L$ ..... Liquid pressure                            |
| $\Delta W_F = \frac{\pi(d_1 - d_0)}{2 \cos^2 \alpha} p_C \mu L_C \Delta L$ | $\Delta W_F$ ..... Frictional resistance               |
|  | $\Delta L$ ..... Expansion length                      |
|  | $d_1$ ..... Inner diameter of expander pipe            |
|  | $d_0$ ..... Inner diameter of un-expanded pipe         |
|  | $L_C$ ..... Cone length                                |
| $\Delta E_P = e_p \Delta V$  | $\Delta E_P$ ..... Plastic deformation energy          |
|  | $E_P$ ..... Plastic strain energy density              |
|  | $\Delta V$ ..... Volume of the expanded casing section |
| $F_C = \frac{1}{4} \pi d_c^2 p_L$  | $F_C$ ..... Pulling force                              |
|  | $d_c$ ..... Diameter of the cone                       |
|  | $p_L$ ..... Liquid pressure                            |

**Equation 10 - 13: Calculation to evaluate the force required to expand a pipe –  $p_L$  evaluated based on implementation of equation 10 - 12 into equation 09**

Based on this consideration the required pressures respectively force to expand the pipe can be calculated. The operational requirements strongly depend on the pre-strain material properties, the expansion cone angle, friction factor between cone and tubular surface and the pre and post expansion geometry (expansion rate) of the pipe.



For a more accurate prediction of the pulling-pushing force several numerical studies underlay with practical tests have been performed (SPE 84943; SPE 105704). The observations made are as followed.

As the analytical solution already indicated the drawing force tends to increase with friction coefficient. (SPE105704) mentions that with an increase of interfacial friction from 0,1 to 0,4 [1] the force requirements double irrespective of trajectory design. Furthermore an increase in drawing force can be observed with an increase in expansion ratio. A variation from 5 [%] to 35 [%] causes a triplication of expansion force. Variations of the mandrel angle from 10 to 45 [°] showed a slight but no significant increase of the drawing force. All biases of the analytical solution are confirmed by the numerical simulations.

## **Expansion cone design**

### Expansion cone angle

Additionally to the increase in drawing force a variation of mandrel angle show an impact in material flow behaviour. With an increase in cone angle, balance between thickness and length shrinkage tends to show more severe thickness reductions while the longitudinal reduction tends to decrease. For high cone angles of about 45 [%] even an increase in length can be encountered. The material to balance for the circumferential and under these circumstances the axial expansion has to be completely balanced by the shrinkage in radial direction. Numerical simulations (SPE105704) suggest an angle of about 20 [°] showing highest drawing force stability while maintaining accurate balance in material flow behaviour.

### Operation mode

Some SET providers allow an expansion process based on vertical and rotational movement of the cone. As the resulting tangential contact force across the cone – pipe surface is shifted with the additional rotational movement, the drawing force is reduced in aid of torque requirement to turn the string. This might be a design option in case of high drawing force expectations, but most simulations and tests performed so far show a significant impact of cone rotation on material flow. The shrinkage in length and especially in diameter of the pipe increases significantly with the rotation of the cone (SPE105704). This fact has to be kept in mind regarding post expansion pipe capabilities.

## **Interfacial friction**

The friction between the cone surface and the pipe can be changed by the variation of material composition and or treatment of the cone and tubular surface, or by the use of lubricants in the operation fluid. Additionally to the increase in drawing force a higher degree of deformation in radial and axial direction could be observed with an increase in friction factor. Numerical simulations show, that (SPE105704) a friction coefficient variation from 0,1 to 0,4 [1] causing the thickness reduction to increase from 15 [%] to 20 [%]. Similar, but not such intensive length reduction responses have been evaluated.

## **Expansion rate**

Today expansion ratios up to 40 [%] can be realized with current techniques and materials. As already mentioned above for the typical expansion process and materials used in the

industry, simple analytical solutions can be used to evaluate the expandability of a tube. For the design of the expansion ratio it has to be kept in mind that as far as the deformation reaches into the plastic region as higher the residual stresses remaining in the material. As a result the anisotropy in pipe stress-strain response in the pre-strained material increases, intensifying the effects on the post expansion capability of the pipe, as it was mentioned above.

## SET in drilling – benefits and applications

Even with the extreme economic uncertainty of the past years and the strong fluctuations in energy prices the further need for hydrocarbons show little sign of waning. Contemporaneously the conventional reservoirs which can be developed and produced based on well proved, cheap and simple technologies diminish.

To cover the future global hydrocarbon demand new technology, boosted by marked related advances in energy price, already convert unconventional and so far unrecoverable resources into economic reserves. Furthermore technological improvements, showing an impact on the efficiency of conventional reserve development and recovery, additionally increase the economic output and guaranty security of energy supply.

One technology which proved in multiple current application and due to its high further development potential to be one part of the technological puzzle, representing the further state of the technological art of oil well construction, is the solid expandable tubular. Based on this consideration, related to increase of commercial SET applications, several regional and international operators as well as service providers founded the ETF forum, where state of technological art is presented and the further development can be discussed. The multiple application areas of SET allow a substantial improvement in oil well construction efficiency and extend the operational options in reservoir development and recovery.

In case of drilling applications the SET in its most fundamental form allow to reduce or even eliminate the tapering effect (telescopic profile) of the conventional casing string design, preserving hole size. As an ultimate goal a single diameter mono-bore consisting of SET strings based on an initially selected diameter and arbitrary number of sections and length, would allow to reach almost any target regardless of the structural down-hole complexity (Figure 09). Reviewing today's commercial SET products, it has to be ascertained that it is still a long way to reach this technological goal of SET in drilling practice but nevertheless the technology already contributes to more efficient and ambitious drilling.

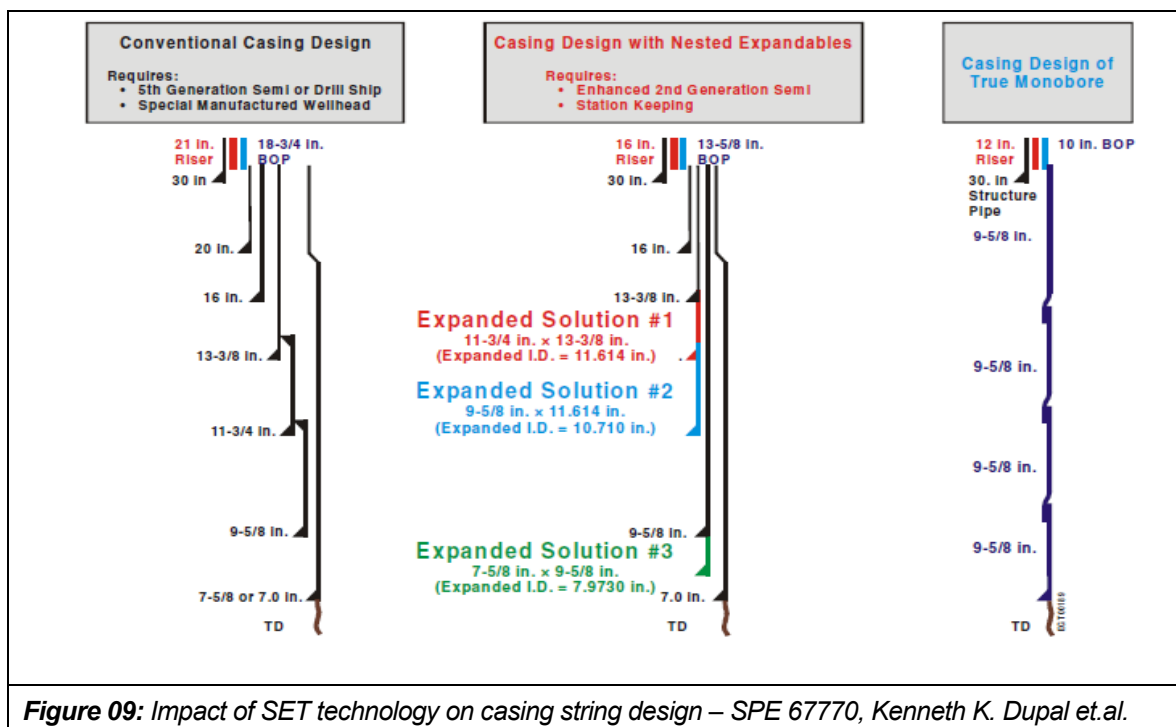

In current applications SETs are used as a part of the initial planning design or a contingency technology to handle unexpected wellbore problems while sustaining the initial targets and capabilities.

Furthermore SETs do have a wide range of applications in completion and workover and therefore add substantial value to existing wells but this issue will not be discussed in this theses.

## **Planned Installation**

SETs, which are already part of the initial well plan design, are in general solid expandable liners extending the length of a conventional string by maintaining hole- diameter. This allows to slim the entire conventional casing profile and/or pushing the drilling envelope while attaining the required casing size at total depth.

Based on several studies, done by industry representatives such as D. Tubs et. al. From Enventure Global Technologies, to investigate the impact of SET, slimming down the well profile reduces the drilling time and cost by improving drilling operation and reducing material costs. The operational influence consists of an increase in ROP due to a reduction in diameter, a better ECD planning and design based on SET optimized casing profile and a reduction in drilling equipment and installation rating (BOP; Riser; drilling vessel) permitted by the load and size reduction.

Additionally, to the economic impact of operational optimization cost savings due to a decrease in material (steel) demand can be encountered. The achievable cost savings using SET based slimming of the wellbore have been estimated to be 15-20 [%], compared to a conventional casing design (SPE-102929). Another strategy, to boost the internal rate of return via installation of SETs, is to use the hole-size conservation capability to deliver larger production/injection diameters across the desired reservoir section.

With operative and material cost comparable to conventional designs the pay out can be strongly increased. To evaluate the cost risk exposure of single SET applications or even individual aspects of the application to compare them to alternative design strategies, quantitative economic risk analyses should be applied. So the risk associated to particular expandable related issues can be quantified and compared to costs of alternative strategies like a non-expandable solution (SPE 107915).

Related to the discussion at the ETF meeting in June 2009 in Stavanger, extending the capabilities of the casing design to reach desired down-hole targets is next to the economics the second intention to implement SET to the initial design. Based on good practice the initial casing design starts with the evaluation of setting depth and number of strings required based on the mud weight program which is related to the pore pressure and fracture pressure prediction.

The setting depth for each individual string has to be based on the required ECD to drill the subsequent open-hole section and the equivalent fracturing resistance at the previous casing shoe. Based on good practices in casing string design it can be mentioned that, the higher the desired drilling depth and the narrower the pore pressure/fracture pressure window as more casing strings are required to reach the ultimate target depth (Figure 10).

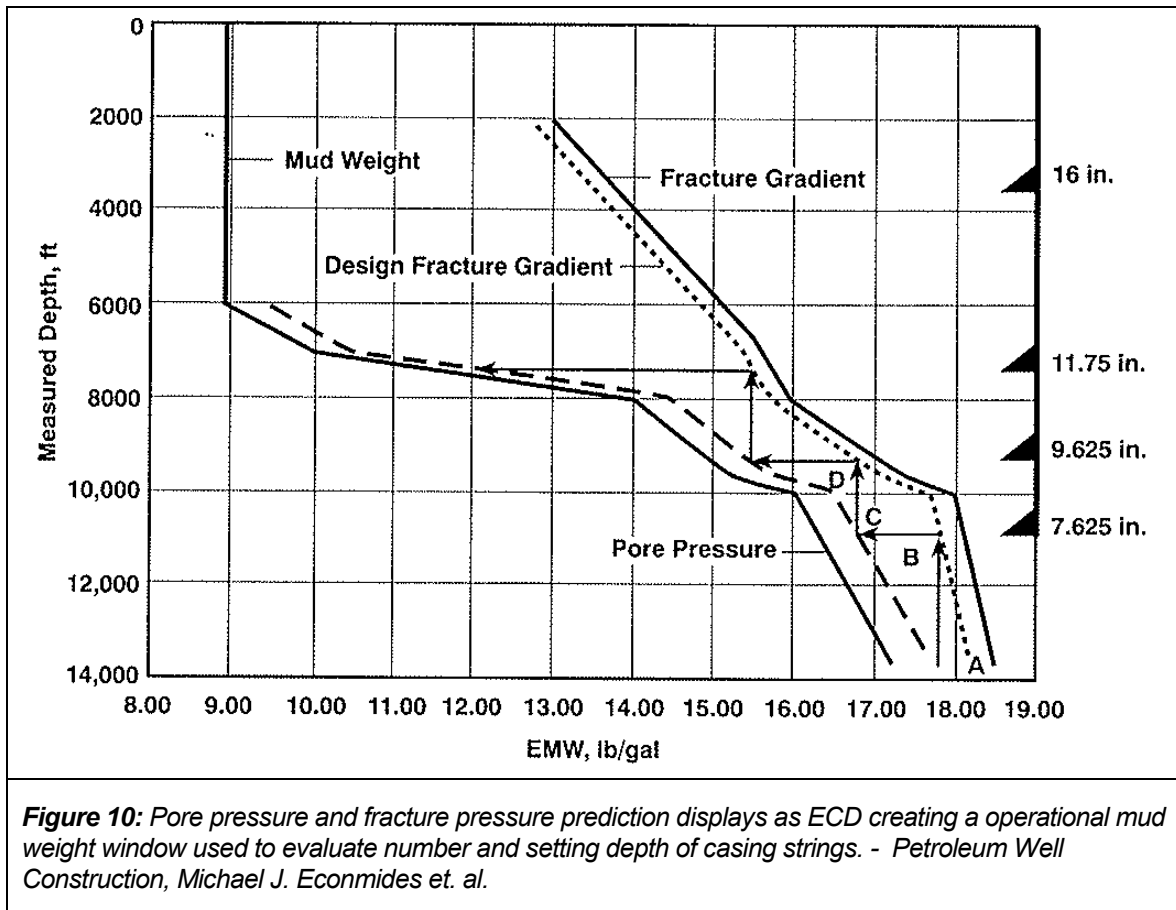

Base on geophysical investigations the shape of the mud weight window is predominately governed by the pore pressure which is influenced by geological structures (faults; seals; anticlines....) as well as physical and chemical processes (dehydration; migration; liberation.....) and the fracture gradient governed by the formation composition, static and tectonically induced stresses and the pore pressure. In general it can be observed that, as higher the geological complexity as more strings are required. Further factors causing a narrowing of the of the mud weight window are a directional well path (Figure 11) and offshore drilling especially in deep water environments (Figure 12), related to publications such as petroleum well construction by Michael J. Econmides et. al..

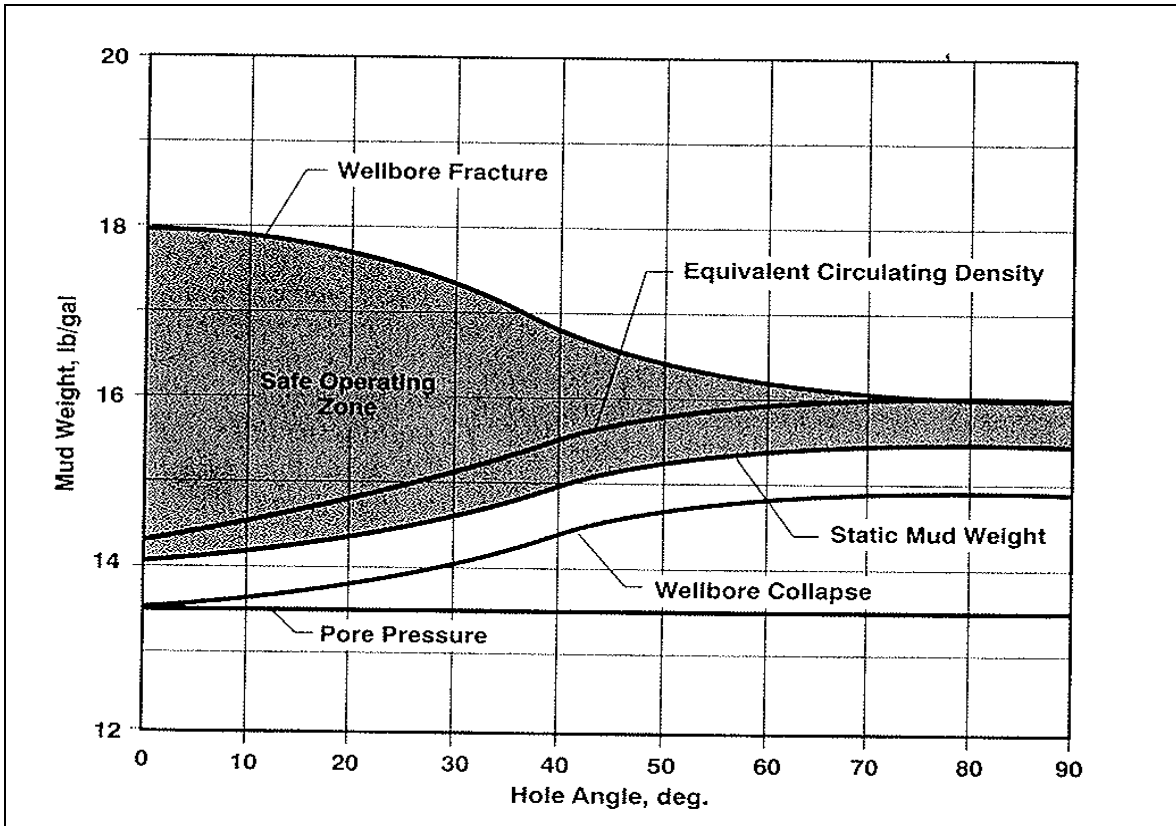

**Figure 11:** Mud weight window slimming effect due to hole-angle increase - *Petroleum Well Construction, Michael J. Economides et. al.*

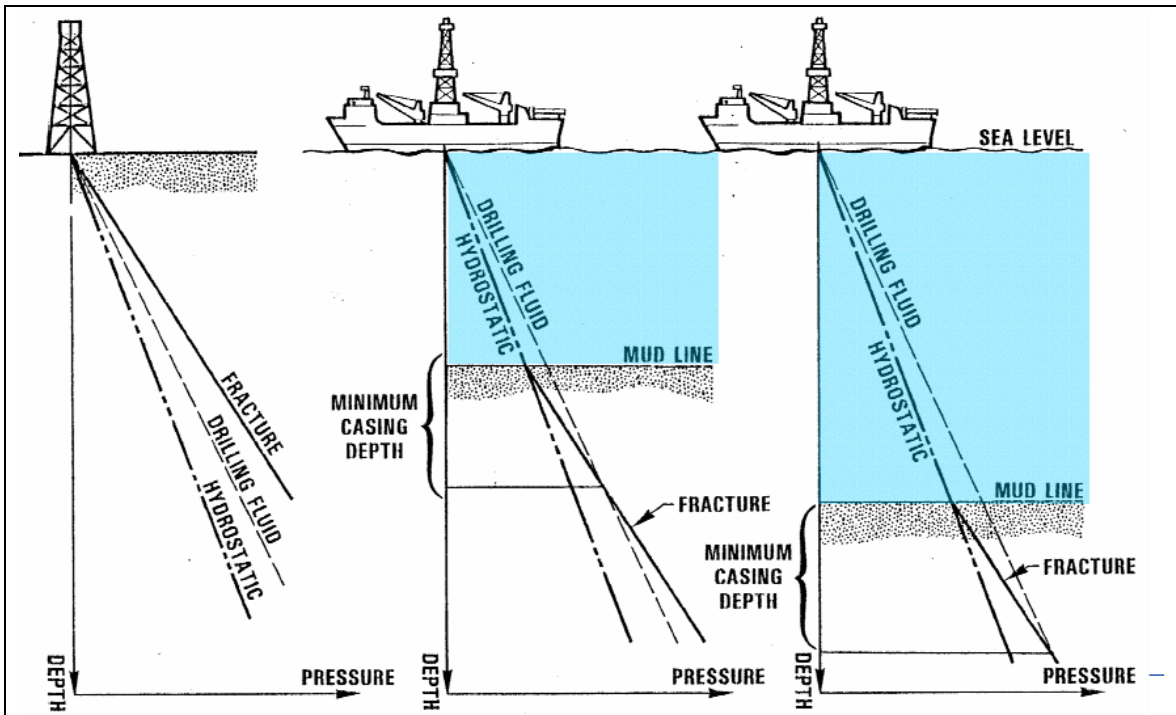

**Figure 12:** Effect of water depth on effective mud weight - *Drilling Engineering III / deepwater drilling, M. Doschek, 2008*

In addition to the required strings, related to the planning based on the mud weight window, known factors like reactive or unstable formations (salt; shale; unconsolidated – formations....) might necessitate additional strings.

With the conventional telescopic casing profile each subsequent casing string diameter is governed by the drift of the previous string. With the final open-hole or casing diameter which is governed by the well objective (exploration; appraisal: development) and the completion design, and the number of strings required, the single diameters can be easily evaluated. The initial and maximum diameter string at the well surface is limited in dimension by the surface facility capabilities and operational limitations governing the actual state of art in drilling industry to be between 24-36 [in].

As an upper and lower bound is given for the typical drilling applications the number of strings in conventional casing design is obviously limited to 6-9 strings (Figure 13). If the hole-size requirements based on the criteria cannot be satisfied with the conventional design a reconfiguration based on the SET technology might allow to reach the desired target.

With the installation of a SEL two strings across one wellbore size can be set without or hardly losing ID. Even with today's strong limitations in SET products range the impact to the casing design can be tremendous.

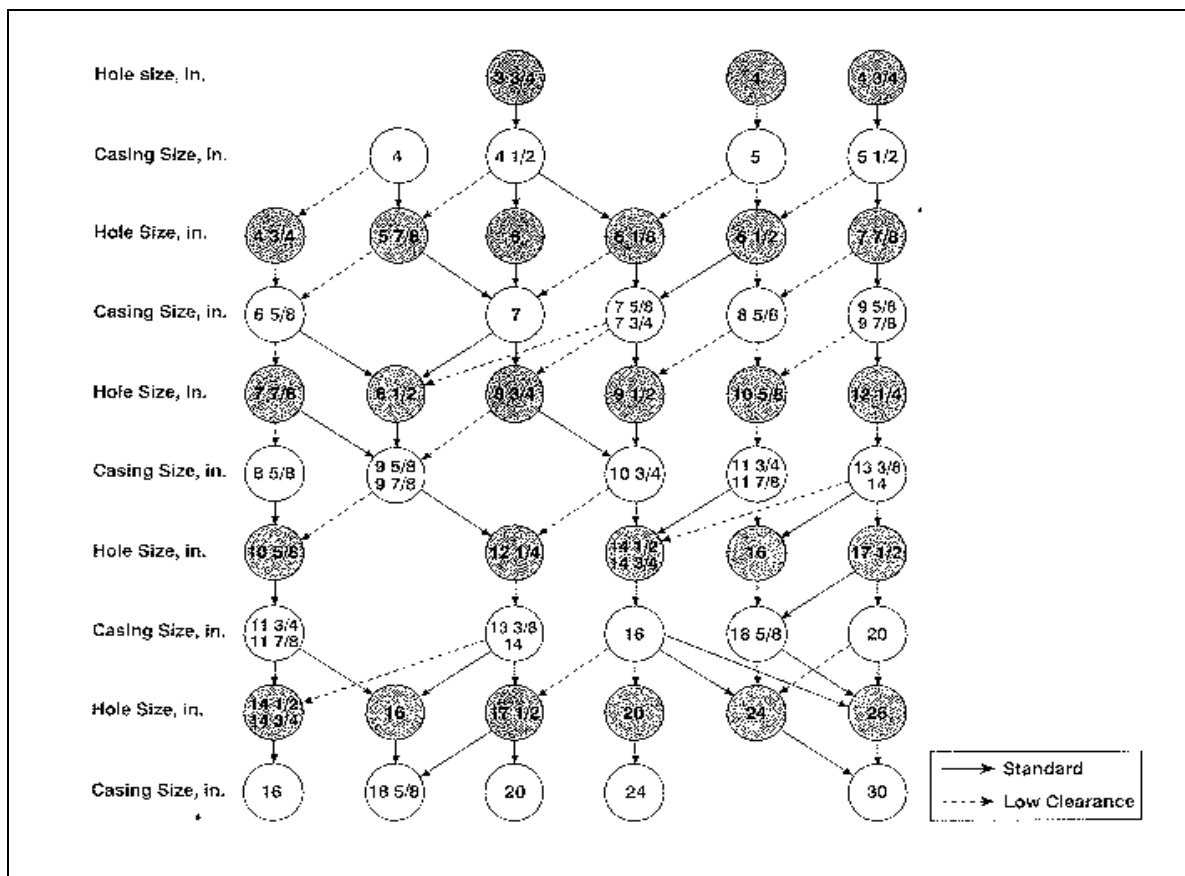

**Figure 13:** Typical graphic tool to evaluate the casing string section diameters based on a fixed prod casing size; today's additional intermediate sizes allow to increase number of strings for conventional designs from 5 up to 9 sections. - *Petroleum Well Construction, Michael J. Econmides et. al.*

## Contingency Installation

SET technology can also be used as contingency installation to handle unexpected down-hole conditions like high pressure or depleted zones, unconsolidated, reactive or fluid loss formations as well as shallow gas. Solid expandable liners as well as open hole clads can be set to isolate troublesome zones while maintaining the hole-size and therefore the initial casing design. Furthermore solid expandable cased-hole liners can be installed to repair leaking or worn casing sections.

Depending on the level of information based on offset (reference wells) and measurement data (seismic) the down-hole conditions are often hard or even impossible to predict and therefore difficult to implement in the initial well planning. Furthermore, these unattended conditions, as well as operational failures, may cause damage at down-hole installations. SET technology as a contingency installation often represents an economic and simple option to handle such operational difficulties.

So far problems which necessitate additional sealing or structural support by unplanned casing string inevitably caused a slimming of the well profile for the subsequent sections. Under these circumstances the well often is not able to meet the desired objectives. Especially in exploration wells where the level of information is at its minimum the planned targets often cannot be reached due to unexpected conditions. With the upcoming option to use different SET technology applications the operational range is significantly extended (Figure 14-15).

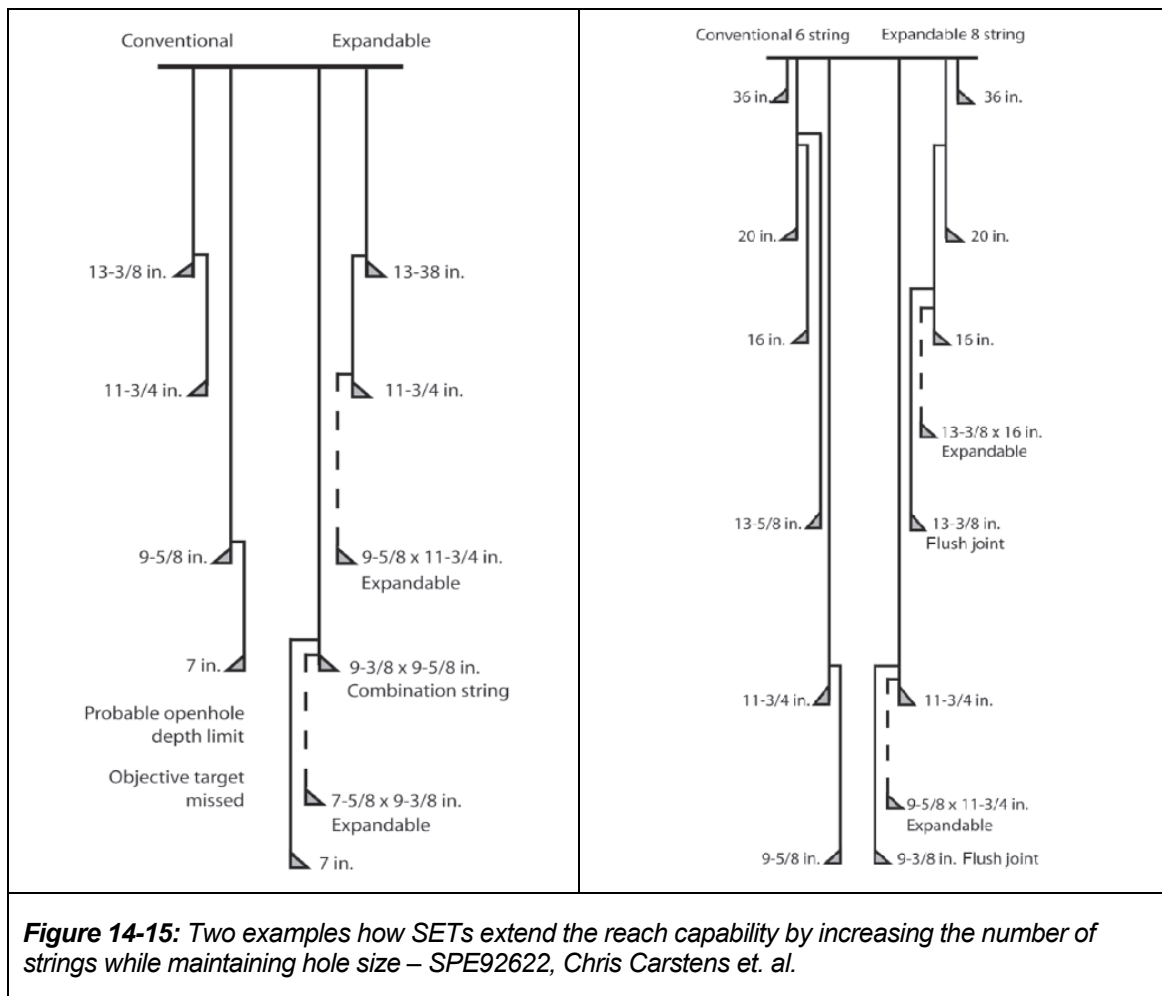



The economic impact of SET as contingency installation is strongly case dependent but facing the fact that down-hole integrity and well control problems might even cause the abandonment of single hole sections or as a worst case even of the entire wellbore, the economic benefit can be tremendous.

## **Application designs**

### **OHL/OHC**

Open-Hole liners (OHL) are, as already mentioned, in the planned installation section extensions of the preliminary string with no or minor inner diameter reductions along the overlap section compared to the base casing string. For the contingency installation of SEL the same criterions can be applied as for the planned installation.

Open-hole liner clads are expandable pipes set without overlap (hanging) to the previous casing string. The pipes are expanded only against the open hole. To anchor the pipe and provide zonal isolation, cementation, as well as the use of swell-able elastomeres coating, proved their accuracy. For high formation integrity even an expansion of the plain steel surface against the open-hole can be performed. Such clads can be used for the same purposes as SEL most commonly for very short or shallow trouble zone applications. After installation the initially planned casing string can be set across the installation as the diameter of the OH is only reduced by the clad wall thickness or if the section was under reamed before setting the OHC no diameter reduction has to be encountered.

### **CHL/CHC**

Cased-hole liners (CHL) or clads (CHC) are systems to repair damaged or worn casing strings. The pipe is expanded with sealing elements ore metal to metal towards the targeted casing section. The reduction of diameter for the casing repair system is based on the post expansion wall thickness. The resulting inner diameter provides in most cases enough clearance to retain the initial casing and drilling program.

# Expandable Open-Hole Liner System

## General-Aspects

The Expandable Open-Hole Liner or solid expandable liner (EOHL/SEL) is today's most commonly installed SET application. A range of international and local providers have created different system designs to utilize the idea of a down-hole expanded solid liner.

The core of all systems is a liner, a casing string which is not extended back to the well head but instead hung from another (base casing) string via a liner hanger. All currently available SEL systems provide typical liner technological advantages like: Reduced material costs; improved hydraulic and work string load performance due to conserved hole-size above the liner; deep well casing placement without exceeding rig load capacities.

As the SEL is expanded down-hole it additionally provides a conserved hole-size across the liner, ranging up to a full mono-bore system with a similar inner diameter for base casing and subsequent liner string. This characteristic will, if the technology proves long term reliability and further improvements, have enormous impact on casing design as the typical telescopic casing profile with successive diameter reduction for each additional string, will hardly be able to compete against the new technological approach in economic as well as technical matter of sense.

Although the available commercial systems differ in some aspects, the major components and the underlying design idea remain equal.

The expansion is largely conducted by an expansion cone. This conical shaped element has at its wider side the desired post expansion internal pipe diameter. It is pushed and or pulled via pressure applied across the tail end surface or via mechanical forces applied over a work-string, through the under gauged pipe.

As the expansion cone propagates through the SEL it is uniformly and permanently deformed, predominately in circumferential direction, ending up with the same inner diameter as the maximum cone diameter. The cone can be slightly different in design. The primary design criterions are the expansion cone angle ranging from a few degrees up to about 40 [°], which represents the angle between the centerline of the device and the cone expansion surface, as well as the length of the conical shaped element. Both characteristics determine the expansion ratio the SEL is subjected to.

Furthermore the cone can be designed as an inflexible rigid body unit (Figure 16) or as a flexible device (Figure 17) activated via axial.

The flexible cones are generally activated preliminary to the pipe expansion with the initial portion of vertical force applied. The procedure represents a reliability risk as all down-hole activated mechanical systems, but it is the only possible design option available so far to achieve the mono-bore target.

The cone which has to expand the pipe to the final internal SEL diameter is accommodated inside a housing attached at one end of the string. In case of an inflexible cone the diameter of the joint is determined by the cone and the wall of the housing.

As the entire element has to fit through the base casing the possibility to create a true mono-bore is already eliminated. With proper design the liner can, as a maximum, reach an inner diameter which is determined by the inner diameter of the base casing minus the wall thickness of the SEL.

Only with a down hole activated cone and thickness reductions of base casing and liner hanger section along the overlap a true mono-bore can be achieved.



**Figure 16:** Rigid body (inflexible) expansion cone – Solid Expandable Tubular Applications, Brent Emmerson (Baker Hughes/2004) et. al.



**Figure 17:** Inflatable (flexible) expansion cone – Expandable Monobore Drilling Liner Extension Technology, Carl Stockmeyer (Baker Hughes/2009) et. al.

Furthermore slight differences in expansion cone shape (cone; melon) and surface design are available trying to minimize the interfacial friction and to optimize the created stress response of the liner during expansion.

All available systems do have an overlap section of base casing and SEL along where the liner is connected tightly to the well casing string. The different design types can strongly differ but some major and general aspects can be identified. The hanging capability is achieved via expanding the liner against the inside of the casing along a well defined overlap section. The overlap interface can be a direct steel to steel contact but most commonly additional bonding elastomeric sections are incorporated along the SEL string, significantly increasing holding force and tightness of the hanger section. Furthermore, the hanger section design strongly depends on the different provided products.

As initially mentioned several different solutions by multiple service providers are currently available on the market. Most of the design types only differ slightly in construction details; only two basically different approaches could be identified. Both designs are offered by marked leading companies and therefore from the authors point of view, representative for the respective design approach. So the following description of the top-down and bottom-up expansion SEL systems are based on the products offered by these companies, and should give a more detailed technical view on the practical application of the SEL technology.

## **Top-down Expansion (Baker-Hughes)**

### **Introduction**

Up to now the system provided by major service company is only available as an extension of 9 5/8 [in] intermediate casing in a high and a low collapse resistance type. So far the product was predominately deployed as a contingency system if the risk of possible down-hole problems is considered to be high. The SEL is expanded from the top of the liner downwards. The pipe is under tensional load in front as well as behind the expansion cone. All axial shrinkage can be referred to the bottom of the string reducing the liner shoe depth. The system is based on a slightly oversized casing shoe which has to be installed as a contingency device, preliminary to the setting, of the 9 5/8 [in] base casing bottom string. The zonal isolation can either be achieved with swelling elastomer sealing elements (coating) or cementation. Based on the shoe and expansion cone design the SEL extension of the 9 5/8 [in] intermediate casing doesn't show any ID reductions along the entire string.

### **System major components**

#### **Expansion Tool**

The expansion assembly consists of a hydraulic stoker (cylinder and piston), an anchor and an expansion cone. It is designed to translate the pressure applied to the drill pipe fluid to a mechanical vertical force utilized to expand the SEL.

The hydraulic anchor (Figure 18) is the top part of the assembly and connected to the work string pipe. The function of the device is to anchor the assembly via radial forces to provide sufficient axial grip to fix the assembly while pushing the expansion cone on the top of the piston through the liner. As the pressure is increased via surface pumps (optional rig pumps or cement pump units) the anchor is activated hydraulically. Gripping slips are extended from the device and forced against the casing wall.

The expansion assembly is locked in place as the created frictional force is high enough to balance for the reaction (counter) force created as the cone deforms the liner over one stroke length. As the pressure is released the radial force pushing the gripping slips against the casing wall diminish and the elements are drawn in, allowing vertical movement of the assembly to run to the subsequent stroke section.

Below the anchor a hydraulic stoker (Figure 19) with an operation length of 14 [ft] is installed. The piston is hydraulically extended via pressure applied over the surface pumps transferred through the drill pipes and the overlying anchor. As soon as the anchor is activated and the pressure is increased via pumping at rates of about 40 [lpm] until (SPE 102150) the elastic limit of the pipe is exceeded, the expansion stroke is initiated.

The hydraulic cylinder has a volume of 220 [l]. When a further pressure increase is detected the piston has reached its full stroke length. To continue the expansion for the subsequent section the pressure has to be released to unlock the anchor and depressurize the piston pressure chamber. By applying weight on bit with open bleeding valves the piston is cycled back to its initial closed position.



**Figure 18:** Hydraulic Anchor – Solid Expandable Tubular Applications, Brent Emmerson (Baker Hughes/2004) et. al.



**Figure 19:** Hydraulic Stroker in extended position – Expandable System Overview, Carl Stockmeyer (Baker Hughes/2007) et. al.

The inflatable expansion cone (Figure 17) is attached at the end of the stroker's piston. Initially the cone is in its unexpanded position with an external diameter of 8 3/8 [in], accommodated within the launcher. The reduced initial diameter of the device permits the ability to run the assembly down hole while maintaining the ability to expand the pipe to an equal inner diameter as the base casing utilizing the activated (expanded cone). The diameter increase is simply achieved by applying axial force pushing the cone on top of the piston forward against the inner surface of the unexpanded pipe.

The single steel wedges, arranged as segments of a cycle alternately and simply supported at the top and bottom segment of the device, are shirtd together while sliding up an internal cone surface. As soon as the single wedges are completely shifted together and the cone axial operation offset is covered by the axial movement of the piston, the maximum cone diameter of 8 5/8 [in] is reached. Further piston pushing force will be directly transferred over the expanded cone to the cone-SEL interface causing pipe deformation, extending the inner diameter of the pipe permanently to the post expanded cone diameter.

When the assembly is POOH the cone collapses again as the frictional forces pull the single elements apart until a stop element in the inside of the cone latches. In the collapsed mode the cone can be POOH with high annular clearance reducing the risk of stuck pipe.

### Running Tool

The hydraulic liner running tool latches into and therefore represents the connection to the liner while running the string in hole. It provides the possibility for an emergency pressure release activated via ball drop and takes liner set down weight without pre-expansion of the string if running through tight spots.

## Retrievable Guide Shoe

The retrievable guide shoe (Figure 20) attached to the bottom joint of the string protects the SEL while running down hole and provides better hydraulics for washing the pipe down hole if necessitated by the well conditions. Instead of conventional guide shoes which has to be milled the device is retrievable via the expansion assembly. This allows an open ID through the entire length of the liner when fully expanded and avoids the milling operation creating commonly problematic junks down-hole. During the last cycle a retrieval collet at the bottom of the expansion tool engages to the guide shoe. Between 9 to 14 [ton] of set down weight are required to shear the nose out of the bottom joint. Once sheared out, the nose is attached to the retrieval collet, and the expansion of the last few feet is completed. As the liner is now expanded completely it provides sufficient annular clearance to retrieve the oversized shoe.

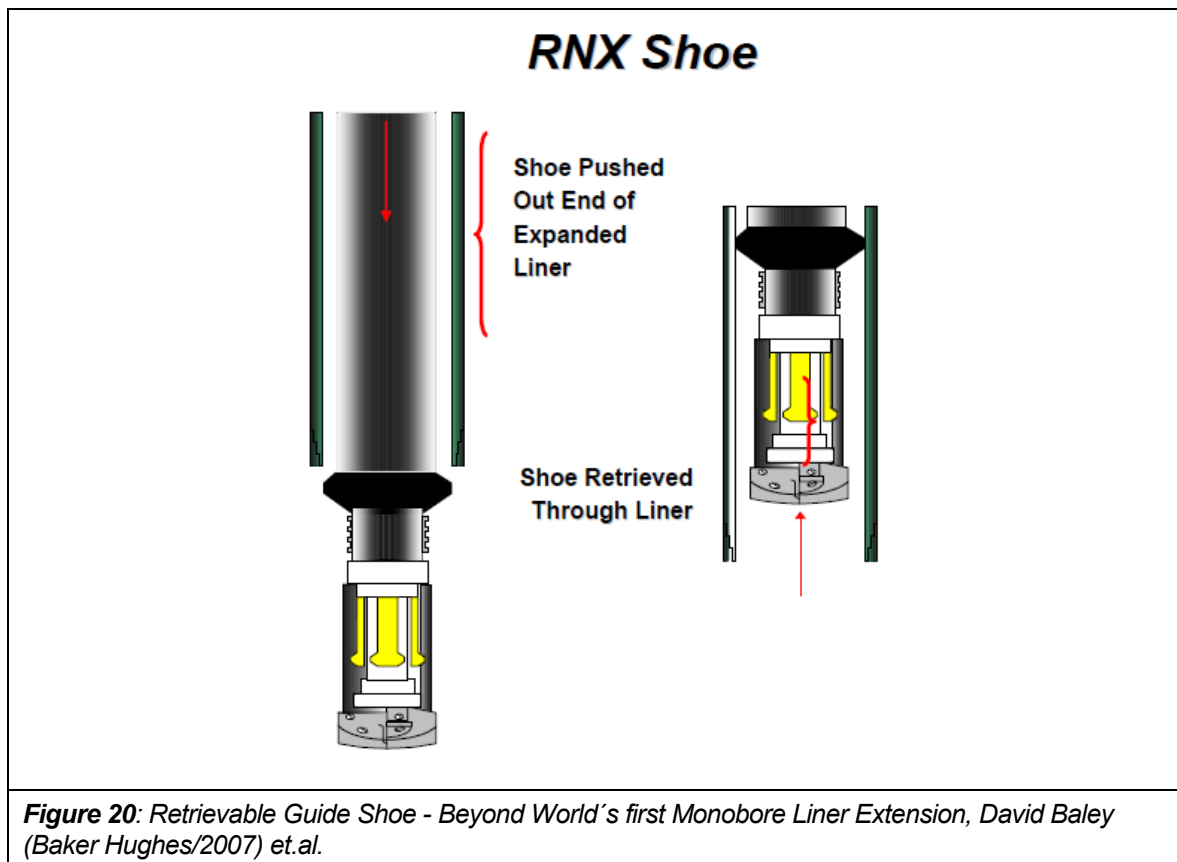

## Recess Shoe

The system provides two different designs for the contingency recess shoe. One which provides flow passes to allow circulation through the annulus of the post expansion SEL permitting the possibility to cement the liner and one without. The second design option is aimed to provide zonal isolation with swell-able rubber packing elements.

The non cement-able recess shoe (RC9) is an oversized casing string component (Figure 21) with a 10 1/4 [in] outer diameter attached at the bottom joint of the 9 5/8 [in] base casing. The oversize in outer diameter and the recess area along the SEL hanging section is necessary to accommodate and hang the expanded liner without causing an inner diameter reduction along the overlap section. The increased inner diameter across the shoe together with the flexible cone and the related ability to be run down hole within a protective housing in a



collapsed mode and anyhow be capable to expand the liner in the expanded mode to the base casing ID, enable the creation of a true mono-bore. The RC9 doesn't provide a cementation option for the expandable liner as no cross-flow can be established between SEL annulus and base casing after the expansion was initiated. Zonal isolation for the liner if required can be achieved with the additional application of swelling elastomer ring elements or a complete coating diverted over the SEL surface. But the shoe allows the cementation of the 9 5/8 [in] base casing while maintaining the hanging capacity.

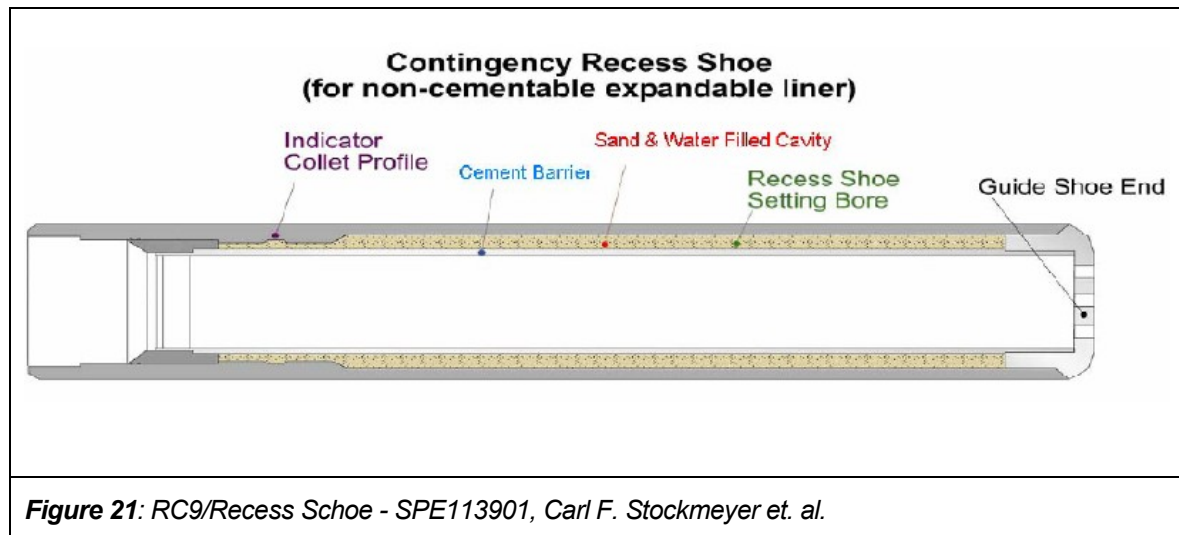

Therefore the major components of the RC9 are two concentric sleeves shifted into each other. The inner sleeve represents the cement barrier protecting the hanger (base casing to liner interface) surface against damage and staining, while cementing the base casing. The outer sleeve represents the hull of the device, with a slight oversizing compared to the base casing allowing an increased inner diameter (recess area) compared to the base casing, which accommodates the expanded pipe.

The inner sleeve is made of composite material and is aimed to guide the cement used to isolate base casing through the casing shoe into the open-hole annulus. Therefore it is tightly connected to the base casing and merges just as tightly into a drillable guide shoe representing the connection at the bottom between the two sleeves. The gap between the inner and the outer sleeve is filled with a water – sand mix. After the primary base casing cement job is finished the inner sleeve as well as the guide shoe and the filling material are drilled respectively cleaned out, with a normal drilling assembly.

A special indicator profile slightly above the recess area of the outer sleeve allows the exact positioning of the SEL in the shoe. While RIH with the SEL string Slag off and pick up readings are taken before and when reaching the desired depth. When the indicator collet latches into the profile it provides 40 [K] up and 40 [K] down indicating the positioning of the overlap section. The pressure rating of the shoe is 5000 [psi] for burst and 1200 [psi] for collapse.

The cement-able recess shoe (RC9-R) (Figure 22) provides the same capability as the RC9 to hang up the SEL in the base casing without inner diameter reduction after installation but further allows the zonal isolation of the SEL via cementation. Therefore a flow pass can be activated allowing cross-flow between liner annulus and base casing. Due to the additional capability the design of the shoe is slightly more complex and an accessory down-hole operated function is added to the system increasing the risk of failure.

Instead of to the RC9-R consists of three concentric sleeves shifted into one another and connected at the top of the tool. The major sleeve is the outer hull of the oversized shoe with

an OD of 11 ¼ [in]. The annular clearance between its outer surface and the formation provides a flow pass and further accommodates the cement to support the base casing string (shoe track).

The lower part of the medial sleeve represents the liner hanger with a recess internal diameter compared to the ID of the base casing along the overlap section. When the SET is anchored via expansion into the recess section of the medial sleeve no inner diameter size restriction is produced.

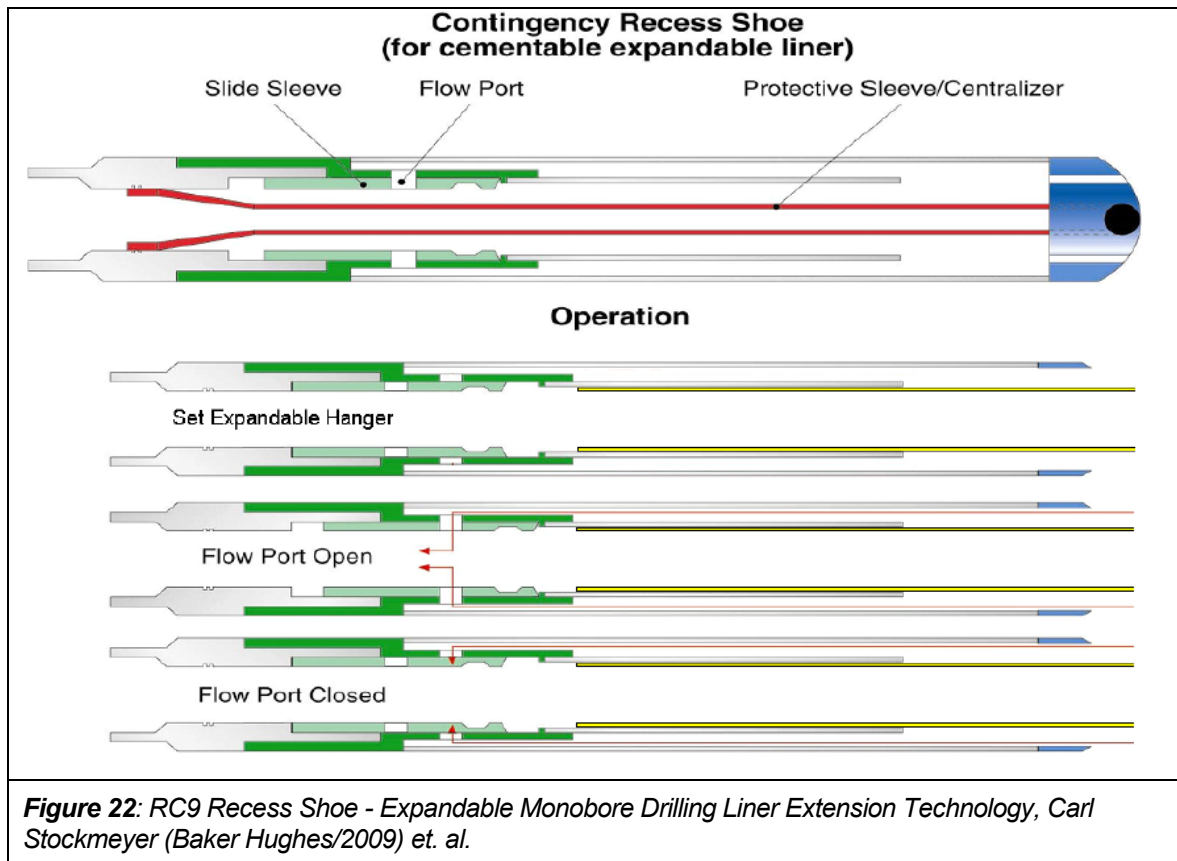

A gap between the outer and medial sleeve represents the initial part of the SET annular flow pass within the shoe. At the top where the two sleeves merge into one another the inner sleeve accommodates a mechanically activated cross flow device consisting of outer and an inner member, which is initially in a closed position. Later four ports will bypass the annular flow along the outside of the SET into the base casing string. It is constructed as a sliding sleeve port, which is opened and closed mechanically via shifting tool, installed as part of the step in cementation string.

The four cross low ports on the sliding sleeve housing (outer member) are 1 ¼ [in] in diameter providing a total flow area of 4,908 [in<sup>2</sup>] the four associated ports on the sleeve (inner member) are 2 [in] in diameter with a total flow area of 12,57 [in<sup>2</sup>]. As it can't be guaranteed that after activation by sliding the sleeve the ports are aligned rotationally, the sleeve is grooved between the seals allow for flow. In this case the flow area is 0,466 [in<sup>2</sup>] for each misaligned port resulting in a total flow area of 3,728 [in<sup>2</sup>].

The inner sleeve made out of composite material is aimed to isolate the liner hanger section and the flow port of the medial sleeve from the cement slurry used to support the base casing. It guides the cement slurry through the shoe over a float collar into the annulus between outer shoe sleeve respectively base casing and formation. After the cement has developed sufficient strength the inner sleeve and float collar are drilled out using a standard



assembly to drill through the cement shoe. The major function of the shoe regarding the cement job is the ability to bypass the annular flow into the casing string after the SET is already anchored to the base casing. This feature allows a more or less standardized step in cementation for the expanded liner.

### System Description

#### Operational sequence

Figure 23 shows that, both recess shoes as already mentioned provide a flow path for the base casing cement job through a composite pipe installation sealing the rest of the shoe. After the cement job is accomplished and the slurry has developed sufficient strength the inner mandrel is drilled out with a standard drilling assembly used to drill ahead. Now the subsequent section is drilled and under-reamed to provide sufficient diameter to set the SEL. The open-hole section is in general drilled with an 8 ½ [in] pilot-bit and under-reamed depending on the zonal isolation strategy. With the RC9-R a hole-enlargement to 10 ¼ [in] is required to provide adequate hydraulics for circulations annular return under a post expanded condition. Using the RC9 a hole enlargement to 9 ½ [in] is required to accommodate the swellable-elastomer packer elements.

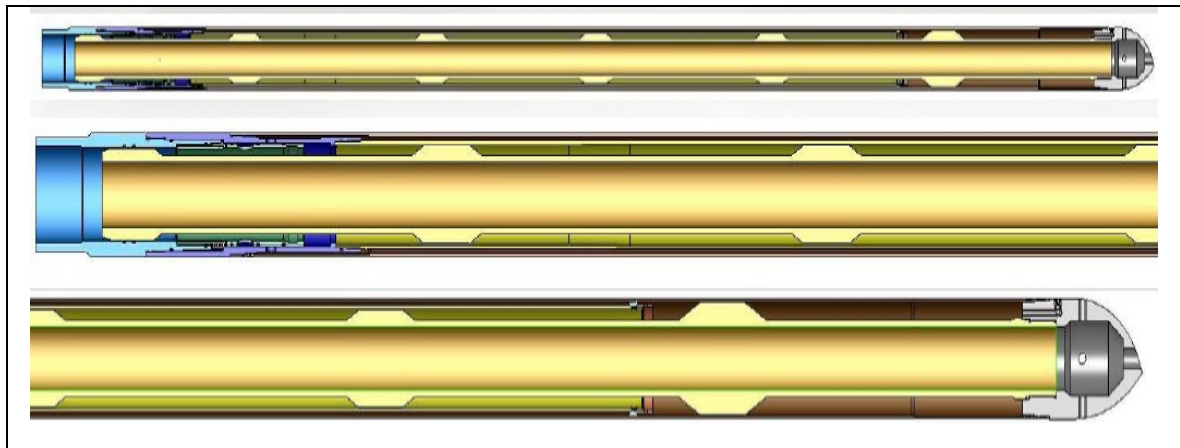

**Figure 23:** Composite Pipe - Expandable Monobore Drilling Liner Extension Technology, Carl Stockmeyer (Baker Hughes/2009) et. al.

After well conditioning the liner installation procedure is started (Figure 24). The surface system is adapted to handle and run the liner pipe; surface procedures are similar to the more standardized chrome tubular installation. The SEL string is assembled and run over the desired length with the retrievable guide shoe installed at the bottom joint. The expansion tool assembly with the pre-described components is assembled and attached to the top joint of the liner string via liner hanger running tool. Now the liner is slowly run to the desired setting depth. The top section of the liner has to be exactly located in the recess shoe. Therefore the indication collet of the string is slowly path through the top section of the shoe.

The string is slowly picked up to engage the indicating collet onto the indicating profile of the recess shoe. Once latched the indicator provides up and down resistance based on the preliminary taken slag of and pull up readings this gives a clear indication, if the string has reached the desired position. Now the expansion process is initiated by breaking the surface connection and dropping the ball to activate the assembly.

After the ball gravitated to its seat pressure build up is performed via mud pumps and slow rates of ¼-1/2 [bbl/min]. The initial pressure build up activates the anchor which provides sufficient counterforce allowing the cone to be pushed through the liner. At a pressure of

approximately 2500 [psi] the piston starts to move downwards, forcing the cone into the liner and starting the expansion process. By continuous pumping while keeping the pressure constant the expansion process continues until the piston reaches its full stroke length, indicated by a pressure increase up to 4500 [psi]. For one stroke 220 [litr] with a rate of  $\frac{1}{4}$  [bbl/min] have to be pumped resulting in an average expansion speed of about 2,5 [ft/min]. Now pressure is bled off to unlock the anchor and allow axial movement of the string. The slack off reading is recorded and the string is run in hole while keeping the top drive open, detecting the backflow.

The string is run in for 13,8 [ft] resetting the stroker to its initial position and set down 4,5 [ton]. With the first stroke the liner is expanded into the recess area of the shoe, the liner outer surface is forced against the hanger area causing sufficient grip to hang up the string. The upper liner joint is special designed assembled with sealing elements providing a tight and strong connection between base casing and expanded liner.

Now the procedure is continuously repeated expanding the liner in 14 [ft] increments. Outside the recess shoe the pump rate can be increased to  $\frac{1}{2}$  [bbl/min] while the maximum expansion pressure diminishes to 1000 [psi] as the pipe is free to expand without an encasing outer profile.

With the final expansion stroke the retrieval collet at the bottom of the expansion string latches into the guide shoe and with 9-14 [ton] the shoe is sheared out of the bottom string. The guide shoe is now attached to the string and after the cone leaves the liner (complete expansion of the pipe) the shoe can be retrieved through the expanded pipe. The exit of the cone is indicated by a pressure drop. The string should be run in for additional 20 [ft] to guaranty that the liner is completely expanded before the string is POOH. If the RC9-R shoe was utilized the cementation is performed with a step in cementation job described later in this thesis.

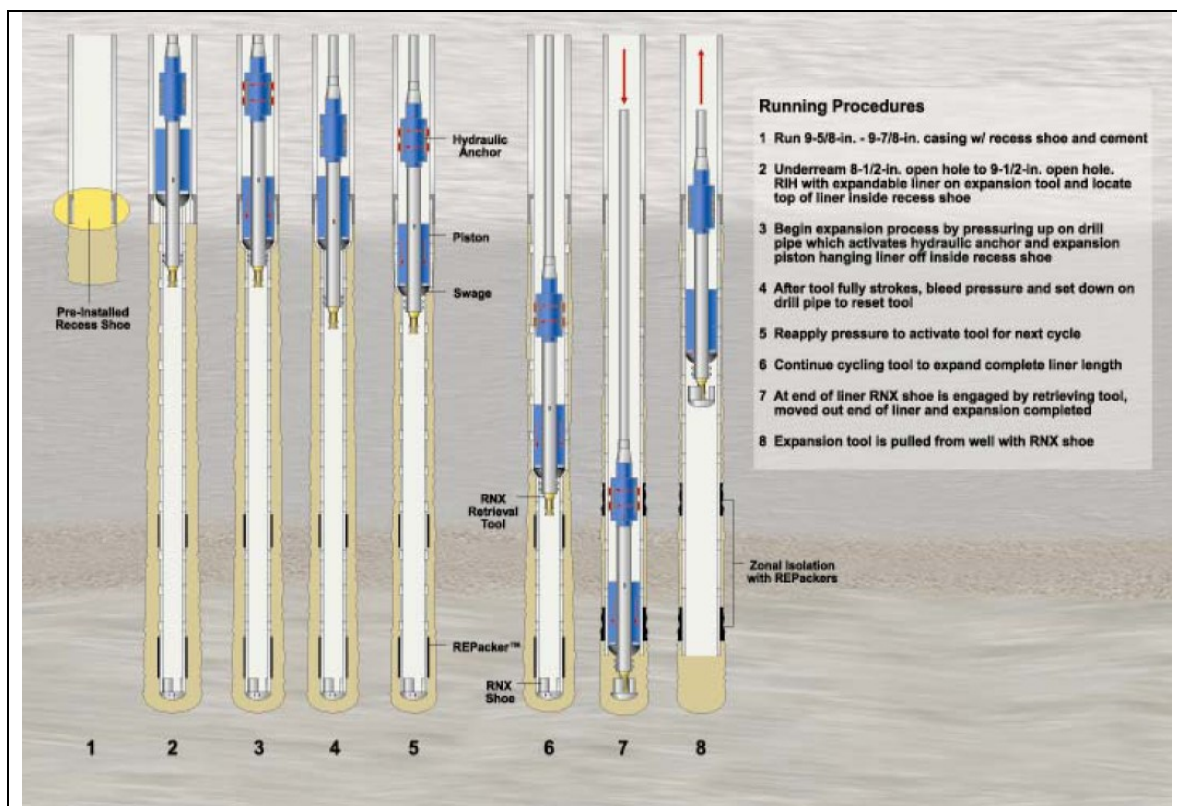

**Figure 24:** System operational sequence - Expandable Monobore Drilling Liner Extension Technology, Carl Stockmeyer (Baker Hughes/2009) et. al.

## **System features**

(1)The primary system feature is the capability to cement the liner post expansion. Although an additional run is required the cement job is simplified as the slurry compositional requirements are lower compared to the pre expansion cement placement.

(2)The oversized casing shoe allows the installation of a SEL without any inner diameter reduction, creating a smooth profile and a maximized drift diameter. But the oversize of the shoe may cause problems while running the base casing string of even necessitate more annular clearance (larger open-hole diameter) for the base casing open-hole section.

(3)The top down expansion allows easy retrieval of the expansion assembly at any point of the process. Problems with annular clearance like junks in the annulus or instable open-hole conditions can impede pipe expansion so in case of bottom up expansion this will inevitable cause the loss of the expansion assembly. The pipe section above this occurrence can with a standardized (section-milling; fishing) procedures still be used.

(4)As the guide shoe is designed to be retrievable a risk involving milling operation can be avoided. Junks created during milling can cause sever problems during the complex SET installation procedure.

(5)The moving parts in the RC9-R shoe allow post expansion cement placement but also represent an operational risk. As known from comparable multiple-stage cement jobs the sliding sleeves often get plugged and cannot be activated accurately.

## **System Performance**

Several notable operating oil companies have utilized the system over the last years. The system was installed in Egypt, Norway (Statoil – Kvitebjorn; Statoil – Kristin) and USA (BP – Oklahoma Arcoma). But nevertheless often only the recess shoe was installed as a contingency device to handle unexpected down-hole conditions. Furthermore the cement less solution is so far the more often finalized system as it is less complex, reducing the risk of system failure.

## **Bottom -Up Expansion (Enventure)**

### **Introduction**

Today the bottom up expansion system offered by Enventure is available for a wide range of specifications and can be regarded as the most established product. It was the first marketable product introduced, in its initial design, in 1999. The expansion of the system is performed from the bottom of the string upward. As no special base casing shoe is installed the cement has to be placed before the expansion of the string is initiated. The casing is hung and sealed via expansion against the base casing string, supported by rubber elements, over a predefined overlap section. As a result the inner diameter of the section is at least reduced by twice the wall thickness of the SEL compared to the base casing.

## System major components

### Launcher

The Launcher is a high strength steel sleeve installed at the bottom of the SEL string. The external diameter of the device equals the base casing string drift diameter while the internal diameter, due to a reduced wall thickness, equals the post expansion SEL diameter. This design allows the launcher to accommodate the expansion cone, which deforms the liner to the desired diameter.

### Nose assembly

The nose assembly (Figure 25) made of composite and aluminum consists from bottom to top of a guide nose a transition nose and a flapper valve. The guide nose is conically shaped to guide and protect the SEL bottom while the transition nose is fitted in the launcher to provide a close connection to the SEL. This allows a certain set down load in case of a stuck string without forcing (pushing) the shoe out of the launcher. The flapper valve inserted in the top of the transition nose avoids backflow into the string and further accommodates the landing surface for the latch-down plug to seal of the nose assembly flow pass and establish the expansion pressure chamber above. The entire assembly is left down hole and has to be milled before subsequent drilling procedures can be progressed.

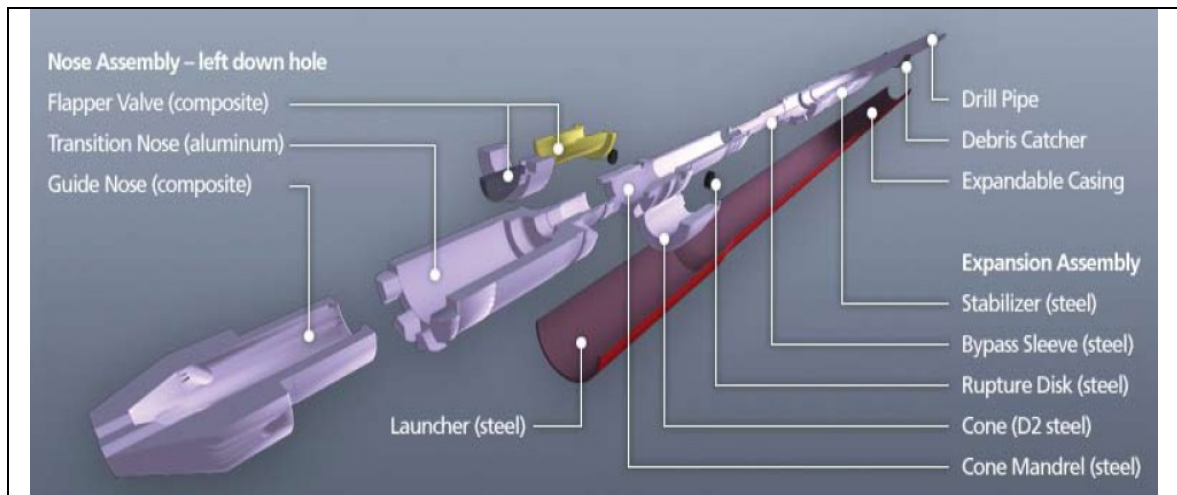

**Figure 25:** Major components of the bottom up expansion system – How SET Technology Work, Enventure Global Technology/2009

### Expansion assembly

(Figure 25) The fixed shape expansion cone is the bottom of the assembly. It is initially placed in the launcher. Not till the entire length of the SEL is in hole and the work string is inserted into the liner the cone is connected to the rest of the assembly. The cone consists of a hardened steel surface representing the interface between liner and cone during the

expansion and an inner mandrel, which provides a flow conduit to the transition nose. Two rupture discs made of steel are holding the cone in position during the running procedure and are sheared off with an initial pressure peak created in the expansion chamber before the actual expansion is initiated. At the top of the cone a screw in safety sub is connected with a pin down connection to its upper counter piece as soon as the liner top passed the rotary table.

The actual work string is based on an accurately dimensioned drill-pipe with some debris catcher subs comparable to cement baskets to avoid junk falling into the SEL during expansion as well as stabilizers to guaranty an axial aligned expansion.

## **System description**

### Operational sequence

(Figure 26) As a preparing step the open hole has to be under-reamed to accommodate the expanded SEL. The necessary annular clearance depends on the product pipe diameter which is available in several different sizes. After the hole is accurately conditioned and cleaned the surface equipment is adjusted to handle the SEL pipes. The liner pipes are assembled and run down hole for the entire string length. The bottom joint accommodates the shoe as well as the cone with a connection sub inserted into the launcher. Now the expansion assembly with the upper part of the connection sub at the bottom is run in hole. The connection with the cone is made via several turns, number of revolutions and torque strongly depend on the system dimension. As soon as the connection is made up the string can be lowered to the desired depth via drill pipe. When the desired position is reached (an exact positioning is not necessary as the overlap provides sufficient play) the cementation of the string can be performed. Therefore the cement is pumped through work-string, cone and shoe into the annulus. A detailed description of the cement placement will follow in the next chapter. After pumping the slurry the latch down plug preliminary placed in the cement head is dropped and pumped down hole via displacement fluid. The landing of the plug in the shoe is indicated by a pressure increase as the flow pass is plugged. Now the pressure build up can be initiated. The flow rate requirements as well as the pressure depend on the system dimension.

All fluid is now pumped into the gap between the sealed shoe and the bottom of the expansion cone as a result the cone is pushed upward. With an initial pressure peak the perforation discs are sheared off and the cone is forced against the liner inner surface. Now pressure, hook load and lifting speed have to be exactly balanced for a homogeneous and adequate expansion. For each stand of drill-pipe pulled and pushed upward the pressure has to be bled off to break the connection and continue the expansion with a new pressure build up. As soon as the cone enters the overlap section the expansion pressure has to be increased as the outer surface and the sealing elements have to be tightly forced against the inner surface of the base casing. Slightly before the cone leaves the SEL pressure and hook load starts to diminish. After the cone enters the base casing the hole is circulated and the string is POOH. The SEL operation is finalized with the milling of the liner shoe assembly and drilling through cement.



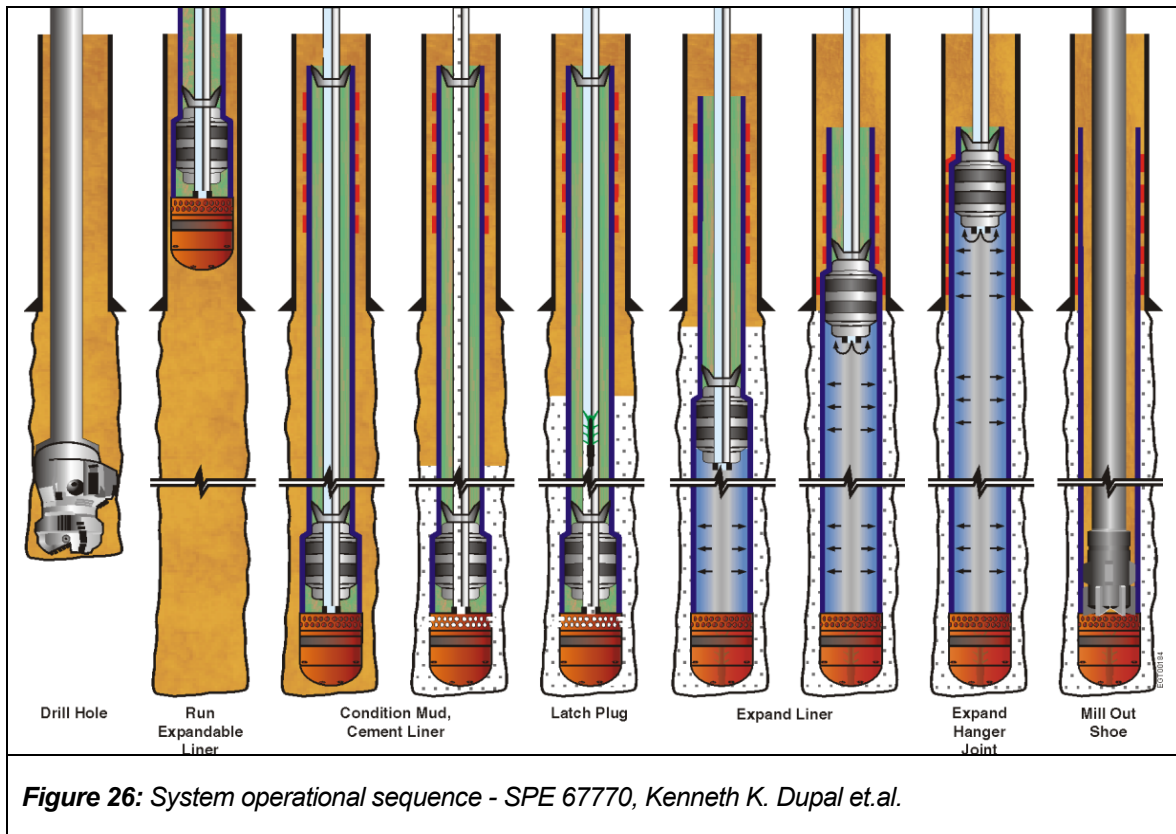

### System features

(1) If cementation of the SEL is considered the cement has to be placed before the pipe is expanded. As the expansion causes a reduction of the annular clearance the slurry is continuously squeezed upward when the cone passes by. This requires long time mobility of the slurry and makes the cement composition design complex.

(2) The bottom up expansion strategy allows keeping the entire string under tension and therefore eliminates the risk of buckling. An uneven and non centralized work-string might lead to a non axial aligned and therefore inhomogeneous expansion. If required the expansion driven by the pressure below the cone can be easily supported by applying additional pull. This might help to overcome tight spots acting against the expansion, so as instable or swelling formations, edges of junk in the annular area of the overlap (hanger) section. On the other hand the bottom up system contains the risk of getting completely stuck. If the expansion process is already started but can't be progressed until the entire SEL is expanded due to whatever reason, the only possible option is to leave the cone down hole. Only parts of the work string can be retrieved. As under these circumstances the SEL remains on its top section unexpanded the entire liner section is lost.

(3) For attaching the liner to the base casing it is directly expanded against the upper string, no special shoe or pipe has to be installed as a contingency device on the base casing. This allows the drilling engineer to use the technique as a flexible tool to handle unexpected down-hole conditions. As preliminary operations doesn't have to be adapted (recess shoe) the decision to utilize a solid expandable liner can be made at each point of the drilling procedure. The downside of the increased flexibility is the inevitable inner diameter reduction compared to the base casing of twice the SEL diameter plus potential reductions due to sealing elements installed across the liner within the overlap section. Today's casing sizes and the

related drifts are in the main standardized, consequently all tools aimed to be run through are related to these drift diameter. The untypical inner diameter necessitates a downsizing or the use of barely standardized tools often causing supply problems and increased expenditures.

(4)The composite and aluminium based shoe necessitates a milling before the drilling operations can be continued. As each milling always contains a risk of operational problems the shoe is kept as short as possible. The axial connection between liner and shoe provides the counter force if, in case of a stuck situation, the string has to be pushed down hole. If the pushing force exceeds the holding force of the shoe it might be forced out of the casing and would drop down. The holding force is proportional to the length of the shoe section inside the SEL. A minimization of this part to reduce the milling section automatically reduces the holding force and reduces the pushing capability. The system design tries to weight both issues accurately but in case of problematic open-hole conditions it might be difficult to run the liner down hole.

(5)The most essential feature of the system is its relative simplicity compared to the alternative. The system contains less complex and mechanically down-hole activated tools reducing the risk of failure and enables the efficient development of an expanded range of available system dimensions.

### **System Performance**

The system with hundreds of applications worldwide (based on provider information) is the actual industry standard. It is the only system available in a certain range of dimensions boosting the scale of applicability. Since first application of the system operation parameters have been continuously extended. Based on information in 2007 the market leading provider has installed 670 SET since 1999 with a total footage of 692256 [ft] and a reliability of more than 90 [%] (including open and cased-hole patches).

# Cementation of SET

## SET cementation techniques

### Post-expansion cement placement

This method is used in combination with the top-down expansion technique, the entire system is offered by Baker Hughes. The following descriptions are based on publications of the system provider as well as of customers, who utilized the system in field applications. Furthermore the system technical reference sheets have been used. With the available information the author is intended to give a descriptive technological overview and to compare the characteristics with the second commercially available system design and the general good cementation practices.

The major prerequisite to apply the system is that the open hole has to be extended to a sufficient size to guaranty accurate clearance allowing stable annular flow after the liner expansion.

The key components of the SET system which permit the placement of cement after the expansion process are a special designed casing shoe installed as a contingency device at the previous (base) casing or liner string, a cement retarder and a step in/stinger cementation string.

### System major components

#### Contingency Recess Shoe

As the oversized casing shoe is installed on the casing string it consists predominately of three concentric sleeves shifted into one another and connected at the top of the tool. The major sleeve is the outer hull of the slightly oversized shoe. The annular clearance between its outer surface and the formation provides a flow pass and further accommodates the cement to support the base casing string (shoe track).

The lower part of the medial sleeve represents the liner hanger with a recess internal diameter compared to the ID of the base casing along the overlap section. When the SET is anchored via expansion into the recess section of the medial sleeve no inner diameter size restriction is produced.

A gap between the outer and medial sleeve represents the initial part of the SET annular flow pass within the shoe. At the top where the two sleeves merge into one another the inner sleeve accommodates a mechanically activated port, which is initially in a closed position. Later on this port will bypass the annular flow along the outside of the SET into the base casing string. It is constructed as a sliding sleeve port, which is opened and closed mechanically via shifting tool, installed as part of the step in cementation string.

The inner sleeve made out of composite material is aimed to isolate the liner hanger section and the flow port of the medial sleeve from the cement slurry used to support the base casing. It guides the cement slurry through the shoe over a float collar into the annulus between outer shoe sleeve respectively base casing and formation.

After the cement has developed sufficient strength the inner sleeve and float collar are drilled out using a standard assembly to drill through the cement shoe (Figure 27). The major function of the shoe regarding the cement job is the ability to bypass the annular flow into the



casing string after the SET is already anchored to the base casing. This feature allows a more or less standardized step in cementation for the expanded liner.

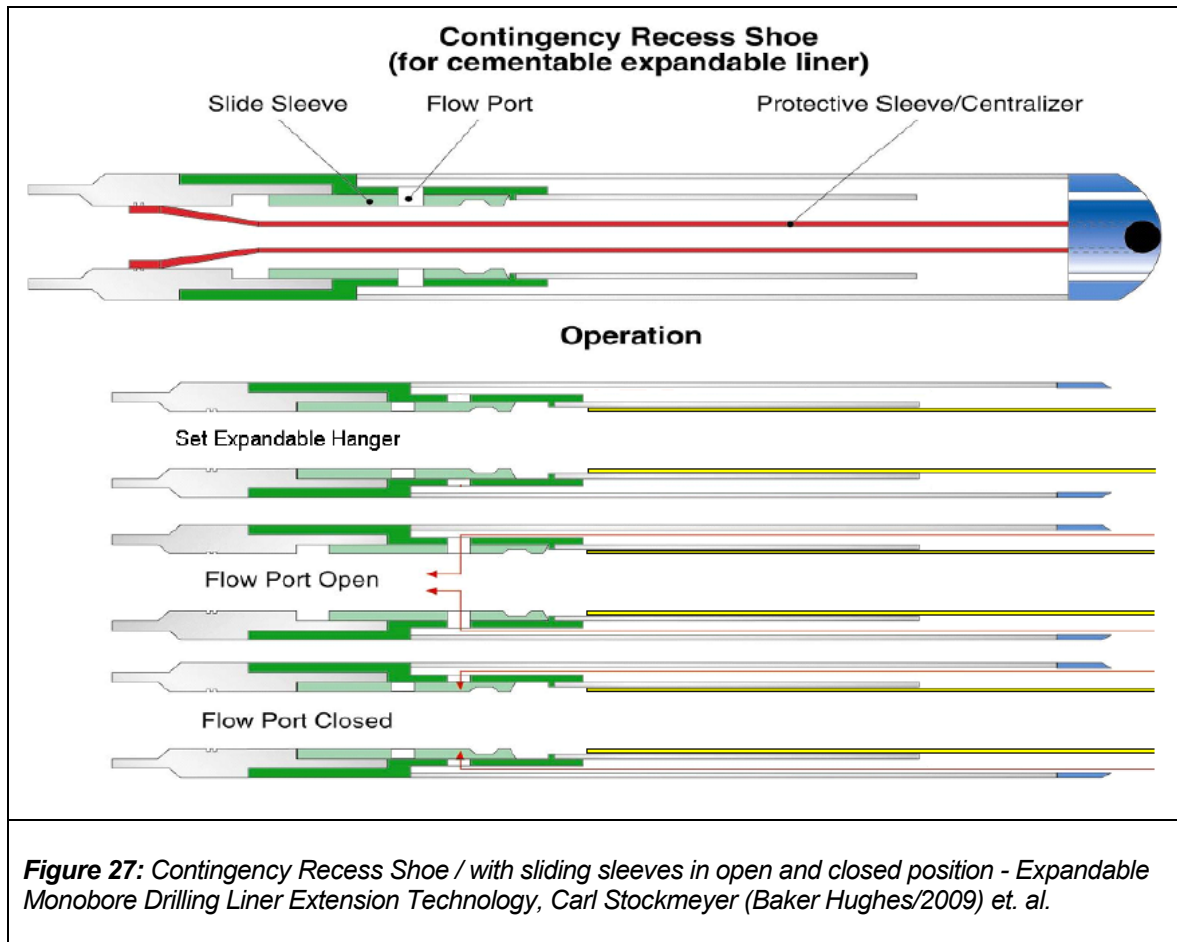

### Cement retainer

A drillable cement retainer (Figure 28-29), which is set in the bottom joint of the SET, is used to seal of the liner inner volume to avoiding back flow into the annular space between stinger string and liner. The tool can be designed to be set mechanically via rotation and or axial loading or hydraulically via pressure.

### Step in/stinger cementation String

The step in sub (Figure 28-29) is the bottom joint of the string which is used to set the cement retainer (setting tool) as well as to latch into it and provide a pressure tight flow path into the volume section below the retainer. So the cement can be pumped through the string, stinger sub and retainer into the annulus of the solid expandable liner.

Slightly above the step in sub a shifting tool is installed to open and close the sliding sleeve ports within the base casing shoe via rotation and axial movement. The rest of the string consists of pipes and additional subs as required to execute the procedures contingent on the particular well specification.

## Cement placement procedure

The cementation process of the solid expendable liner starts with the running and setting of the cement retainer attached on the stinger. As soon as the desired setting depth in the bottom joint of the SEL is reached the retainer is activated and the stinger is dis-latched. The string is pulled up until the shifting tool reaches the right position to open the bypass sliding sleeves within the base casing shoe. After opening the port the string is run back to the bottom and the stinger sub is latched into the cement retainer. After circulation is initiated the desired cement program can be pumped. The slurry is circulated over surface units, through the singer string and retainer, up the annulus between open hole and expanded liner, trough the annular gap between the outer and medial sleeve of the base casing shoe, through the open bypass port into the shoe (annulus between stinger string and shoe) and up the annulus between stinger string and base casing.

As soon as the cement is in place the circulation is stopped, the stinger is dis-latched and circulation is restarted immediately to remove the cement which was pumped into the casing. The string is pulled out until the shifting tool reaches the accurate position to close the bypass port. Now the stinger can be pulled out of hole and a milling assembly is used to drill out the cement retainer and the residual cement.

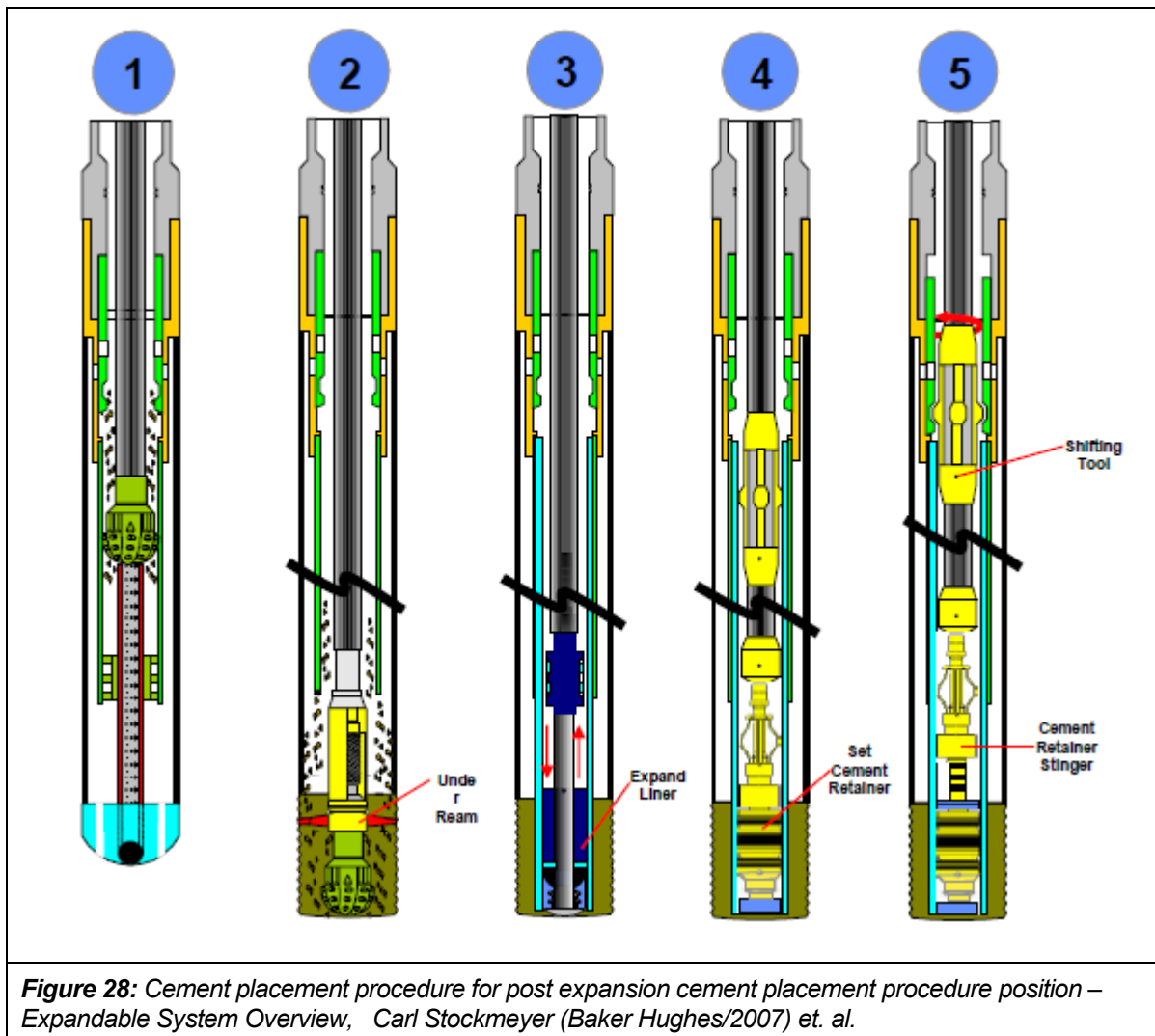

**Figure 28:** Cement placement procedure for post expansion cement placement procedure position – Expandable System Overview, Carl Stockmeyer (Baker Hughes/2007) et. al.

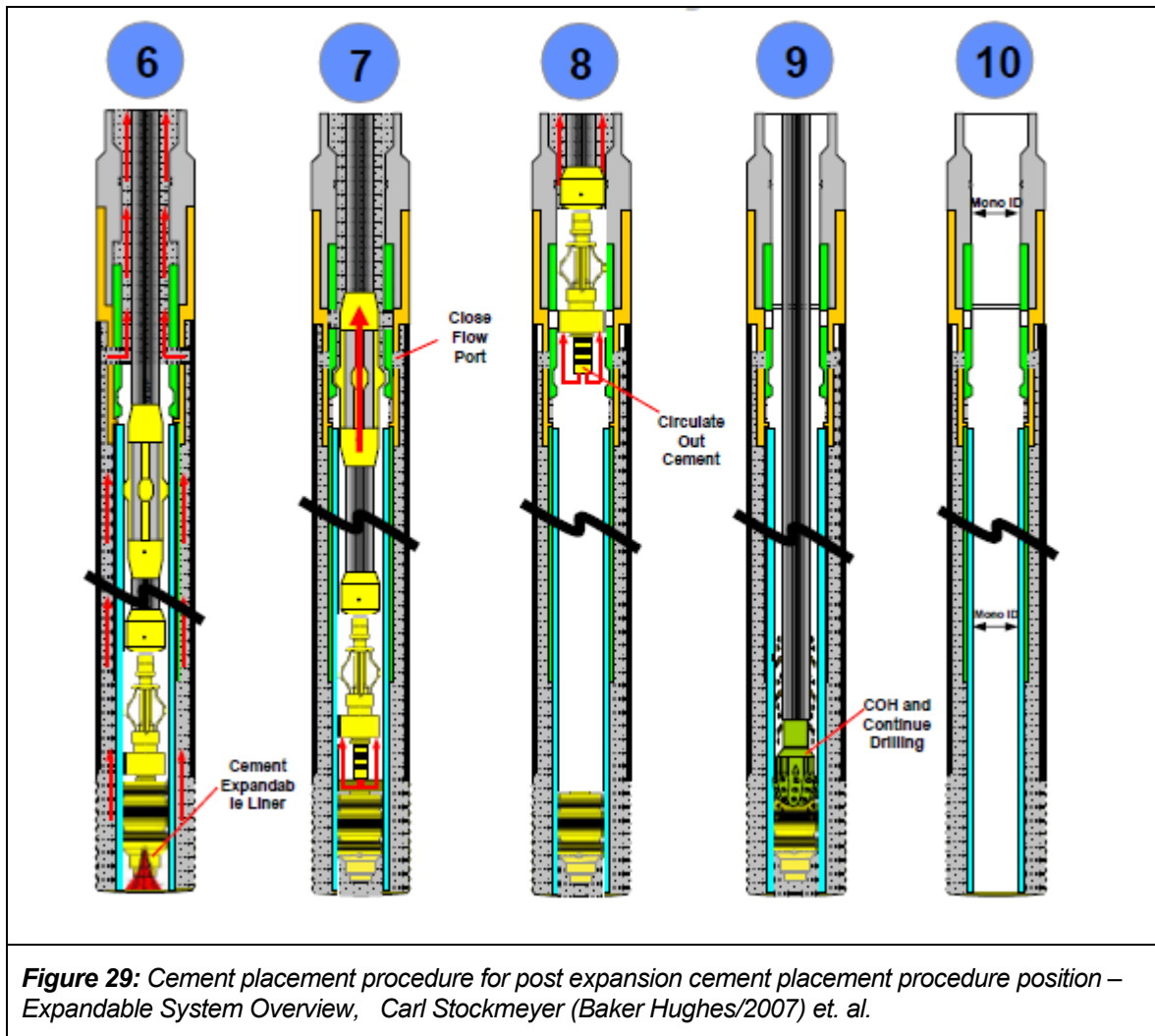

### System features

(1) The cement placement into the annulus requires a certain minimum clearance which is higher than the clearance requirements to achieve a good cement bond quality. So an over gauge allocation has to be created to place the slurry which wouldn't be necessary if the cement would be placed into the pre-expansion annulus. The wellbore has to be more extended as compared to other available technologies.

(2) The most essential feature of the post expansion placement technique is the fact that the cement job duration is reduced compared to other technologies. As the expansion is already performed when cement is placed the procedure hasn't been taken under consideration for the cement job design. The experience shows that with each planned or unplanned extension of job duration the risk of failure grows significantly.

(3) Until now, related to the system performance update of the ETF meeting in June 2010 in Stavanger, the system was only applied in a few wells, and so far couldn't prove reliability over a wider range of wellbore specifications. Furthermore the system contains several down-hole operated and activated devices (stinger, retainer, sliding sleeve port) increasing the risk of failure.

## **Pre-expansion cement placement**

The method is used in combination with most bottom up expansion systems. The cement is pumped into the annular space between SEL and open hole before the expansion process is initiated. As the annular geometry changes with the expansion the slurry has to stay liquid during the entire process to allow the displacement of the slurry upwards along the shrinking annular clearance. All volumetric calculations have to encounter the post expansion annular geometry to guaranty an accurate cement job design. Especially due to the fact that flow into the overlap section between base casing and SET as well as an overflow into the SET have to be avoided to ensure functionality of the system, the volumetric calculation is a special concern for this cement placement strategy.

### **System major components:**

#### **Work string**

The string allows the placement, expansion and cementation of the SET (Figure 30). The major string components are an accurate sized drill pipe and the expansion mandrel which is screwed onto the string down hole during the running procedure of the SEL. During the expansion process the conical shaped mandrel will be pushed (pressure) and pulled (draw work) through the pipe. The mandrel always provides an accurately sized center bore as a flow pass for the cement and the expansion fluid, which will be pumped through the string.

#### **Launcher**

The launcher (Figure 30) is the bottom joint ore shoe of the SEL string and constructed of thin wall high strength steel, that is thinner than the expandable liner to accommodate the expansion mandrel. At the bottom of the equipment a float collar provides a flow pass for the cement into the annulus. The float collar bore design contains a landing surface to accommodate a dart to seal of the annular space after cement placement and allow pressure build up between the collar and the mandrel to initiate the expansion process.

### **Cement placement procedure**

The cement surface equipment and operation is more or less similar to a conventional cementation through the drill pipe (work string) (Figure 30). The slurry is pumped through the drill pipe, expansion mandrel and float shoe into the annulus. The annular fluid is displaced along the liner open-hole section and the gap between unexpanded SET and base-casing up to the surface. The cone inside the launcher is carrying the liner weight along a conical contact surface. The enormous contact force between cone and launcher acts additionally to a bust disc as a seal avoiding any backflow into the section above the cone. A dart following the cement slurry seals of the flow pass via landing in the float shoe and allow pressure build up to initiate expansion. During the expansion process the cement level in the annulus rises continuously as the annular clearance decreases. The slurry has to maintain liquid during the whole process to avoid expansion and or formation problems

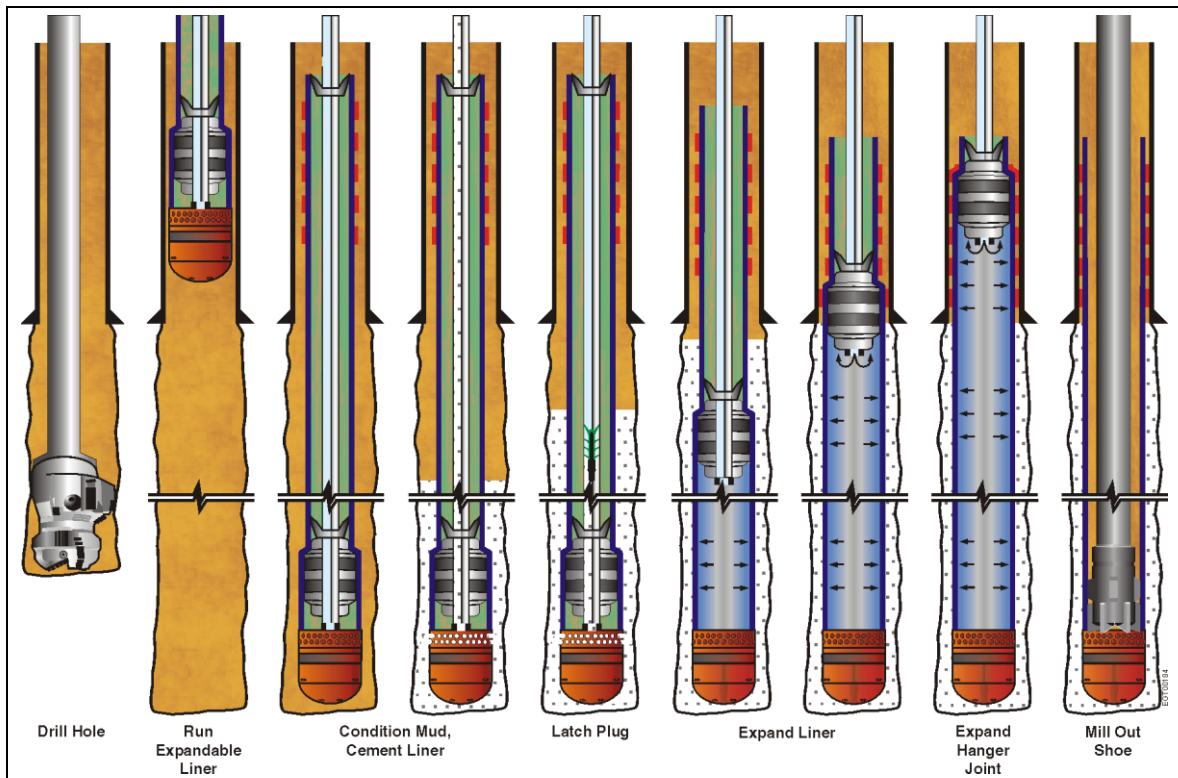

**Figure 30:** Cement placement procedure for pre expansion cement placement procedure – Bottom Up Expansion - SPE 67770, Kenneth K. Dupal et.al.

### System features

(1) As the placement of the slurry is performed before expansion, the annular flow pass requirements do not necessitate additional hole-enlargement procedures to guarantee accurate flow within the annulus. The clearance between the un-expanded pipe and the open hole should in general be sufficient to allow the cement placement. The remaining annulus after expansion can be significantly smaller as it would be required to place the slurry. So the over gauge requirements can be predominately correlated to the SET expansion rate and are less compared to the post expansion cement placement.

(2) In comparison to the post expansion placement or any other primary cementation technique the procedure regarding cementation is amplified by an additional operation. During the expansion process the slurry is subjected to an extremely low periodical flow rate. With each stand the expansion cone is forced through the SET the annular clearance along this section is reduced by the amount of expansion. With the reduction in annular volume the slurry is displaced upwards causing a rising top of cement. The slurry condition during this time can be classified as uncommon as the flow ranges from static to an extremely low rate. The created fluid shear and its influence on the slurry behavior are hardly be simulated so far, but plays certainly an important role

(3) The volumetric design requirements have to be based on the post expansion specifications, which has to be taken under consideration for top of cement evaluation and design. Along with this, special precaution has to be taken to avoid problems with cuttings lifted while pumping the cement. The overlap section (hanger section) of the SET, which is expanded against the base casing, shows high sensitivity to solid impurities. Residual cuttings

transported up the annulus and accumulated within this section might lead to a leaking liner hanger.

Cuttings lifted by the slurry above this section might even fall back into the un-expanded SET. During the expansion process those solids might cause severe problems. The liner might get damaged or the work string may even get sucked.

(4) The cementation practice is the today most commonly used cement placement technique. Based on the system performance update at the ETF meeting in June 2010 in Stavanger, over the time since adoption several dozens of applications worldwide have been performed more and more improving system reliability. Therefore service companies offering SET technology with pre-expansion cement placement most commonly have a growing degree of experience reducing the risk of failure.

# **Cementation Optimization of SET**

## **Well preparation and conditioning**

The optimum well preparation already starts with the drilling of the desired casing section. Especially with the application of new technologies such as SEL the generally accepted guidelines should be reviewed to account for requirements coming along with the application. So the objective of drilling a well as economic and safe as possible has to be at least adapted to include the creation of an optimum wellbore for successful cementation. This allows the utilization of the new technology with all its advantages while simultaneously offsetting aligned disadvantages by the improvement of well known procedures. For the economic considerations the entire picture has to be regarded, including the risks involved with a failed cement job.

## **Open-Hole Quality**

For the SEL application especially wellbore stability and highly gauge hole are major considerations. All kind of irregularities such as wash, break outs or any other kind of inhomogeneity in wellbore geometry aggravate technology related problems such as the poor centralization capability. In general it has to be outlined that drilling hydraulics, drilling fluid chemistry, drilling tools and drilling operational parameters such as weight on bit or rotational speed have to be optimized to meet this additional objective. The optimization of those parameters is strongly related to the individual drilling situation, such as well profile, formation geology and lithology. In conjunction with the hole-quality consideration it has to be outlined that the SEL related hole-extension requirement additionally complicates the situation.

So for each individual situation in which the SEL application is considered the engineers have to take the accurate action by adjusting the drilling parameters to achieve maximum hole-quality. Finally the hole has to be checked with a caliper log run to take corrective measures if it is necessary.

The influence of calliper conditions, over a related average radial diameter increase, on the centralization capability for SEL, is analysed via simulation in the following chapter. The results should allow to make quantitative statements of the influence of hole quality onto the centralization capability necessary to achieve good cement quality.

Furthermore, the wellbore should be as smooth as possible minimizing doglegs and toruosity.

## **Solid removal and mud conditioning**

The drilling fluids should be designed to create a thin filter cake which is easily to remove preliminary to the cementation. A mechanical re-movement of filter cake via scrapper runs should be performed. Afterwards the hole has to be checked once again for obstructions.

Residual drilling cuttings ore other junks inside the wellbore can have enormous influence on cement job quality. Therefore accurate cutting removal is in general an important factor fore wellbore cementation. Especially for deviated and horizontal well profiles aligned with the SET characteristic narrow annulus, the cuttings tend to accumulate along the cementation sections instead of the bottom of the hole.

Before the casing is run down-hole the well has to be circulated clean to ensure that residual drilling cuttings are removed as efficient as possible.

As cuttings often are created not only due to the drilling procedure but by erosion of open hole or while running the new casing string, which due to the extreme low annular clearance in case of SET application becomes even more considerable. Several bottom ups should be

circulated after the string was run to its desired setting depth. During this operations mud rheology and flow rate should be optimized for cutting removal.

Finally, the mud properties have to be optimized for mud and filter cake removal. Therefore the yield point and viscosity have to be reduced as well as the gel strength to increase the mud mobility.

### **SET centralization**

Under ideal vertical and tensional setting conditions the physics dictate that cross-sectional pattern of a well-bore with a pipe string centralized on the top anchor point would show two concentric cycles. This well defined ring shaped annular profile is favorable for all aspects of pipe cementation and therefore the aspired goal of casing setting (Figure 31). As soon as the well profile slightly deviates from the vertical the distance from the outer boundary (open-hole or base casing) start to vary (Figure 32). With an increase in well-bore curvature (deviation in azimuth and inclination) the casing tends to shift away from the center until, at a certain point depending on the initial clearance, the pipe contacts the outer cycle. From now one with any further increase in curvature the pipe will rest on its low side on the wellbore wall.

Even in case of vertical well profiles slight deviations will always be part of the trajectory. So a perfect centralization over the whole length of the pipe will never be achieved. For today's more and more common directional well profiles the casing string would continuously contact the wellbore walls almost disables the cement job to meet its objective. This fact necessitates the application of supporting string components to partially recentralize the casing. Over decades those centralizers have been developed and improved for typical casing and liner applications. With the appearance of the SET technology the good centralization technique became obsolete. Due to the SET special features a long range of adaption of the current techniques and procedures is required.

### **Classification**

To qualify the degree of centralization the API Standoff was defined. It is based on the eccentricity which is the distance between the centre of the hole and the casing. The eccentricity ratio (Equation 14) expressed as a percentage is called standoff (Equation 15). The value for standoff ranges between 100 [%] – completely centralized to 0 [%] - contact between casing and wellbore wall. The APE recommendation for minimum standoff to achieve an accurate cementation is 67 [%].

|                                     |         |  |
|-------------------------------------|---------|--|
| $\varepsilon = \frac{e}{r_H - r_C}$ | ε.....  | Eccentricity                             |
|                                     | e.....  | Min. deflection casing/<br>wellbore-wall |
|                                     | rH..... | Open-hole radius                         |
|                                     | rC..... | Casing outer radius                      |



|  |  |
|--|--|
| $Standoff[\%] = \frac{e}{r_H - r_C} * 100$ | $\epsilon$ ..... Standoff                          |
|  | $e$ ..... Min. deflection casing/<br>wellbore-wall |
|  | $r_H$ ..... Open-hole radius                       |
|  | $r_C$ ..... Casing outer radius                    |

**Equation 14-15: Pipe eccentricity and standoff calculation**

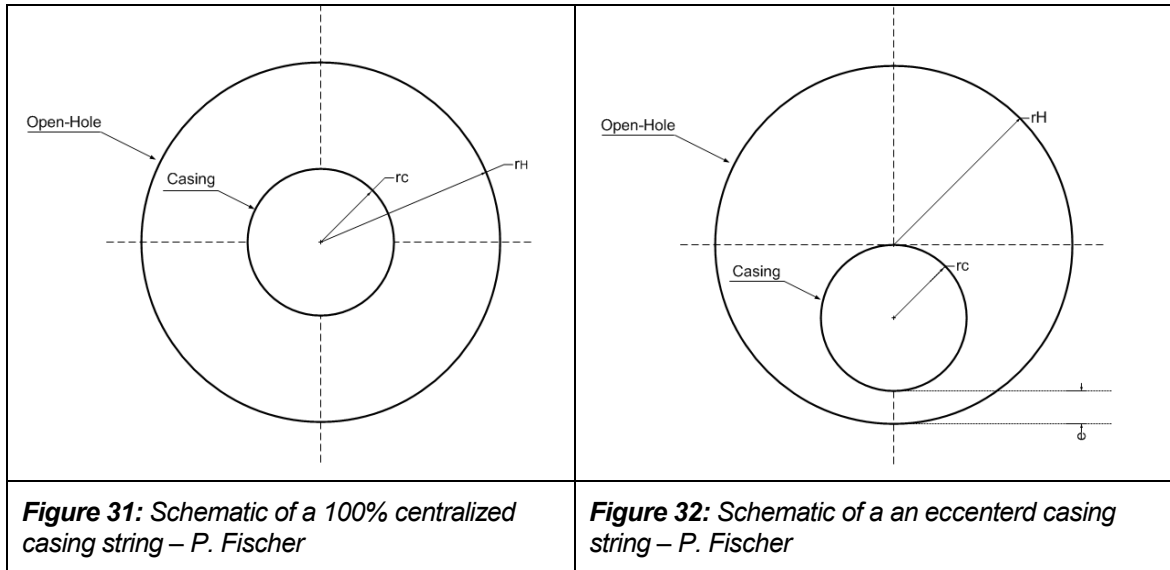

### Centralization matter

There are two major reasons why centralization is a major concern for cementation. It improves the cement placement, creating a more uniform wall thickness which contributes to cement stability and zonal isolation and it further improves the filter cake and mud removal contributing cement bond quality. As an additional side effect the installation of centralizers reduce the drag and differential sticking while running the pipe.

The influence of centralization on cement job quality can be related to one primary effect. The eccentricity changes the ideal flow pattern in the annulus (Figure 33). The flow velocity in a non-centralized annulus is not uniform. On the side of the hole with the largest clearance a velocity maximum can be observed while a minimum can be encountered at the point of lowest clearance (Figure 33). Most numerical simulations and analytical calculations published such as SPE 109563 by Larry Moor et. al., SPE 24406 by Idir Azouz et. al. or SPE 80999 by I.A. Frigaard et.al. show that most of the fluid flows in the wide annulus, on the narrow side the flow corresponding to the eccentricity increase tends to stagnate. This causes problems in wellbore preparation as well as cement placement.

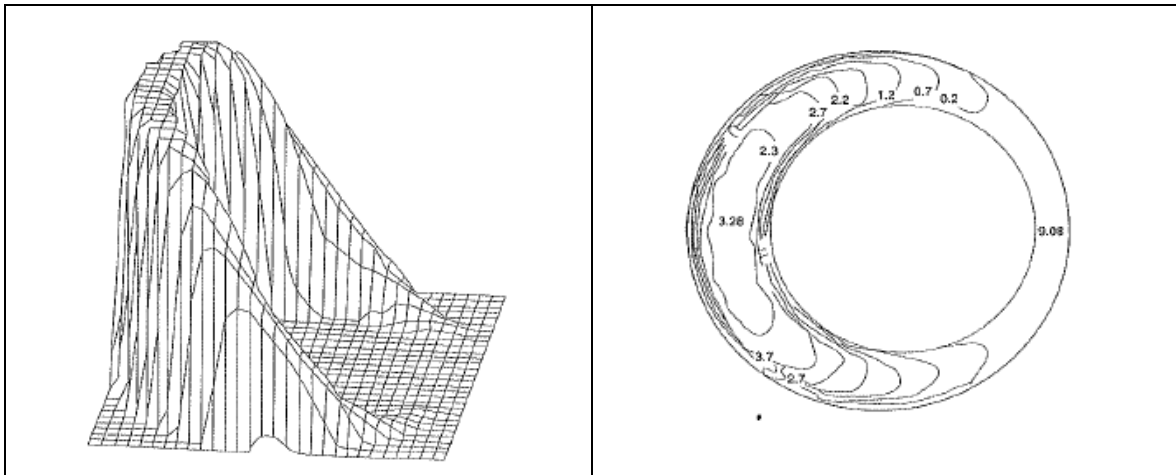

**Figure 33:** Flow velocity profile of a Bingham fluid in an eccentric annulus. - *Petroleum Well Construction, Michael J. Economides et. al.*

As already discussed the removal of drilling fluids, mud cake and pockets is essential for an accurate cementation. During the preconditioning of the well it is tried to remove those drilling residuals among other things via conditioning of mud properties and pumping of washers and displacing fluids. To prove effectiveness fluid flow has to be enabled to contact all portions of the wellbore. With an increasing degree of eccentricity the conditioning via the mentioned techniques become more and more inefficient on the narrow side of the annulus. Mud residuals and filter cake can't be removed and in the worst case contaminants already carried in the stream might even get trapped and start to accumulate within the gap between pipe and wellbore wall. The flow problem continues throughout the cementation process. As the slurry is pumped in place it flows predominately through the wide part of the annulus while the cement coverage on the narrow side due to the minor flow velocity and the irremovable and entrapped residuals turn to be inefficient. Under those circumstances the objectives of a pipe cementation especially in highly deviated wells could never be achieved without taking measures to improve the flow regime.

### Centralizer designs



**Figure 34:** Conventional bow spring centralizer – *SledgeHammer Oil Tools Pvt. Ltd.*



**Figure 35:** Conventional rigid centralizer – *SledgeHammer Oil Tools Pvt. Ltd.*

The most common strategy to create a more homogenous flow profile is to reduce the eccentricity by the installation of centralizers. Those components are attached on the casing string to keep it off the borehole wall and create the high as possible standoff. For common casing and liner strings several different designs are available.

The spring bow centralizers (Figure 34) are due to their design flexibility the most commonly used system. They consist of oversized spring like bows clamped helically or in line with the pipe axis between two rings. The bows are flexible but stiff enough to force the pipe away from the wellbore wall creating positive standoff. Due to the flexibility of the spring bows the casing string components can even create standoff in irregular shaped ore over-gouged hole-sections. Depending on the bow height they can be designed for low ore high annular clearance.

The second important design is the solid collar centralizer (Figure 35). These solid oversized helical or linear attachments can be welded on short joints, which are screwed between normal pipes or they are glued directly onto the casing string. They are not flexible but are able to stand higher restoring forces and therefore recommended for highly deviated and horizontal wells, where the weigh component transferred via centralizer onto the wellbore wall is high.

### **SET centralizer adaption**

For the new SET technology the established centralizers have to be adapted to meet the characteristics of the casing technology. Major concerns for this reinvention is the low annular clearance while running typical SET strings and the expansion of the pipe it selves.

The SET outer diameter for most applications is only slightly less than base casing drift diameter. This technology characteristic is aimed to the fact that the expansion ratio is limited and furthermore with increasing expansion ratio the post expansion capability to withstand the down-hole condition is decreased. So for application of SET it will always be tried to keep the expansion process to the required minimum, causing low annular clearance while running through the base casing. Those tight restrictions in general mean high running forces with poor restoring capability for the centralization. Based on these circumstances the application of centralizers is strongly limited to down-hole activated and ultra low clearance devices.

Secondly and most problematic the centralizers attached on the SET has to join the expansion process without causing any destruction on the casing or constricting the process while maintaining or generating centralization capabilities. Expansion ratios up to 40 [%] necessitates to brake new ground in material selection and construction of centralization devices.

So far several designs have been developed to meet these objectives but those are hardly tested over accurate range field applications.

### The close tolerance expandable centralizer

The close tolerance expandable centralizer for expandable tubular (CTEC) (Figure 36) is based on the spring bow design. The centralizer system is run in hole in a collapsed mode to allow passage even through ultra tight restrictions. The centralizer is activated with the expansion process. The expansion of the pipe and the resulting reshaping of the device create the centralization capability. This primary design feature allows low annular clearance but restricts the design application predominately to the post expansion cement placement technique.

The device is based on several bows clamped between two end rings. Initially those bows are under slight compression but not allowed to bend shaping the typical bow. Therefore

additionally to the primary end rings fins are attached on the bows and glued together forming a closed ring under un-expanded conditions, preventing the axial elements from bending. During the expansion the end rings are reshaped to take the post expansion diameter without restricting or disturbing the expansion process of the pipe. The variable geometry of the end rings is achieved via arranging multiple metal plates on a flexible band. Under pre-expansion conditions the plates represent a closed ring glued together without gaps between the plates. With the expansion the glued connection is sheared of via shifting of the plates along the band which preserves the circumferential integrity and holding the device together. Along with the expansion the fin based intermediate rings are sheared of along the glued connection allowing the bows to bend regarding to the apparent stress situation within the bows. As the pipe shrinks in axial direction with expansion and as the end rings remain in position, additional compression is induces in the axial elements causing the bows to bend in a bow shape and deflecting the SET away from the wellbore walls.

Normally stop collars are used to avoid axial movement of the spring bow centralizers during the running as well as in place. So far it wasn't possible to develop a stop collar capable to stand the expansion process. For the actual design the necessary holding force is provided by the bows in the collapse mode and later on after expansion the end collars (rings) provide sufficient residual tension to hold the centralizer in place. The system so far was successfully applied in several field tests as outlined in SPE paper 26752 by Holger Kinzel et. al. and at the ETF meeting in June 2010 in Stavanger by Baker Hughes.

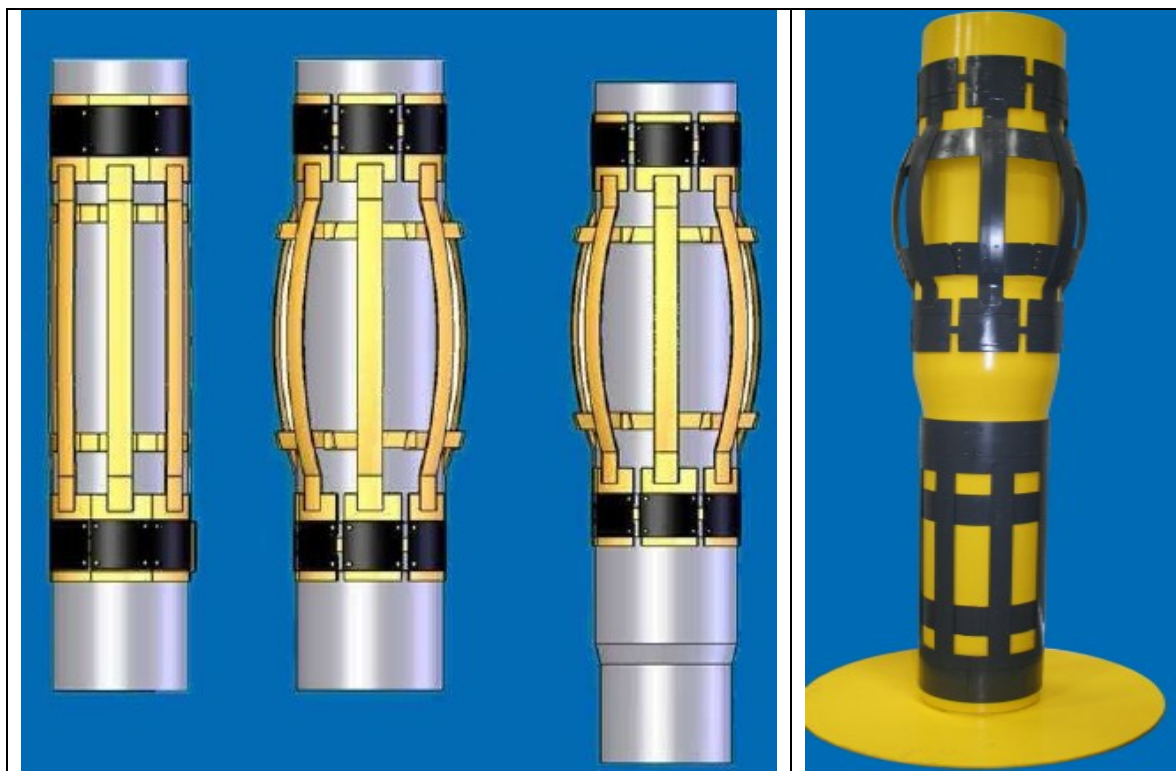
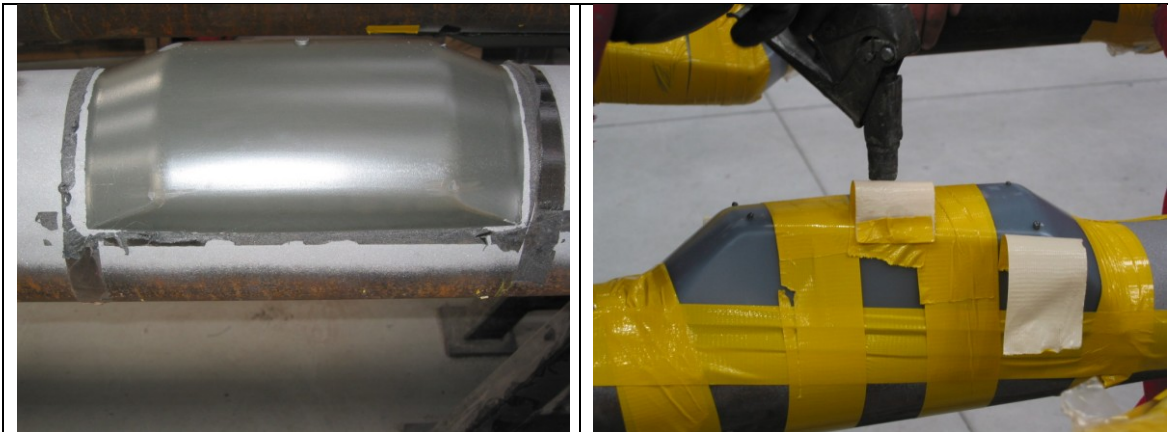

**Figure 36:** The close tolerance expandable centralizer schematic and picture - Expandable Monobore Drilling Liner Extension Technology, Carl Stockmeyer (Baker Hughes/2009) et. al.

### Rigid Solid Centralizer

The simplest form of centralizers the rigid solid centralizer (Figure 37) which is as a special design the only system already applied commercially in combination with SET technology. It

consists of metal plates helically glued or sprayed on the pipe. The tests and commercial applications didn't show any negative effect on the expansion process or the post-expansion capability of the pipe, but the application shows an enormous positive impact on cement quality (SPE 124965). The influence onto SET material along the centralizer and the reliance of the glued connection nevertheless has to be further investigated. As the system performs the centralization with a simple partial pipe oversize the application is restricted to the available annular clearance, but provides high restoring force capability.



**Figure 37:** Rigid centralizers made of spray metal able to withstand pipe expansion without losing centralization capability / recommended by SEL providers – Montage Protech Centralizers, RWE Dea AG, Halliburton-Protech

### Down-Hole Activated Centralizers

Another method to centralize SET, which wasn't applied under field conditions so far, is the use of a plurality of telescopic cylinders as an insert to the pipe body (sub) distributed over the pipe length as required. The system allows the pipe centralization prior to the expansion and is designed for ultra low annular clearance. The cylinders are closed at one end and can be activated and extended by applying internal pressure or mechanical action. One unit consisting of four cylinders arranged radial in a ninety degree phasing. Several of these units have to be applied to create a positive standoff for better cementation quality. After cement placement the pipe is expanded with its telescopic members still extended. When the expansion cone passes the centralize sub the cylinders remain extended and are pushed into the borehole wall.

This down-hole activated system is still in development but would provide due to the high flexibility related to the expansion independent activation and the high restoring force several advantages. But nevertheless the system hasn't proved reliability and the influence on the pipe capabilities and the expansion process aren't accurately investigated so far.

### **Alternative strategies**

It becomes obvious that centralization of expandable tubular still is in the fledgling stage, although a lot of different appendages may turn out to be an accurate solution.

So far for SET applications of it was commonly disclaimed to use centralizers, but to offset the negative influence several optimization approaches regarding the cement program can be followed.

Especially the rheological behaviour of all involved fluids is a key factor to improve the cement job quality even in case of a not completely centralized casing string. In the following chapter a fluid optimization strategy is outlined to cover the negative effect of low standoff values

## Cement slurry design and preparation

### Governing Parameters

The cement slurry behavior governing parameters are mostly investigated and described in a range of scientific studies. Most national and international standardization organizations provide recommendation values and testing procedures to support the operators and service companies by implementing a good and comparable cement slurry quality. The extensive standardization is based on today's good practice for primary cementation jobs. As the entire well design and the related cementation operations are founded on a consistent state of art the cement slurry requirements are within a certain range consistent too. Today's standardization is based on this relation.

However with the implementation of new technological approaches like solid expandable liners the requirements concerning cement behaviour as well as the test procedures have to be adapted to meet the new technology characteristics.

Furthermore the different SEL technological applications differ significantly in the amplitude of divergence to the established standards. For the post expansion cement placement via step in cementation the operational sequence is largely following a standard operational sequence the necessary alignments are far less than for the pre expansion cement placement. As the operational sequence, the slurry is subjected to, is extended by the expansion process in which the slurry has to remain pump-able at ultra low rates for a significantly extended time the cement design has to be accurately adjusted.

### Thickening Time

Regardless which placement procedure is applied the slurry has to remain pump-able during the entire operation. Therefore the thickening time, which quantifies the time the cement slurry is pump-able, has to cover all operations until the cement is placed at its final position within the annulus.

The thickening time of the slurry is defined by API as the time the slurry required to reach a consistency of 100 [Bc]. Today slurry is in general designed for a value of 70 [Bc]. The consistency unit "Bearden Unit of Consistency - Bc" was introduced to quantify the pump-ability and can be related to the torque response of an API standardized consistometer by Equation 16.

|                                     |               |
|-------------------------------------|---------------|
| $B_c = \frac{T[gcm] * 78,2}{20,02}$ | T..... Torque |
|-------------------------------------|---------------|

**Equation 16:** Bearden unit of Consistency

The parameter is a slurry and well condition dependent characteristic, which can be adjusted within a certain range. The operations and the related time requirements strongly depend on

the placement system in use, but also on the specific SET and cement service providers, and has therefore be evaluated for each single job

The time requirements for the entire stack of planed operation the slurry has to maintain its pump-ability are the base for the slurry thickening time design. The adjustment of the pump-ability is based on the cement selection and the addition of certain chemical additives. A typical operational sequence and the estimated time requirements for the tow SEL technologies outlined in this thesis are listed in Table 03.

| Pre Expansion Cement Placement |                                  | Post Expansion Cement Placement |                                  |
|--------------------------------|----------------------------------|---------------------------------|----------------------------------|
| Operation                      | Estimated Time Consumption [min] | Operation                       | Estimated Time Consumption [min] |
| Cement Preparation             | 250                              | Cement Preparation              | 250                              |
| Cement Placement               | 105                              | Cement Placement                | 130                              |
| SEL Expansion                  | 420                              |                                 |                                  |
| <b>Total Time Requirement</b>  | 775                              | <b>Total Time Requirement</b>   | 380                              |

**Table 03:** Time estimate of an operational sequence of cement placement for a 620 feet SEL string

In general it can be ascertained that if the cement is placed per expansion the thickening time has to be increased by the time period necessary to expand the casing as the slurry is subjected to slow motion. Due to the expansion of the pipe the cross sectional annular area is reduced over the length of diameter increase. With each stand expanded the cement in the annulus squeezed upwards. This causes a period during which the cement is, after the actual placement, subjected to periodical flow of ultra low magnitude. Although this sequence cannot be classified as typical cement placement period as the mobility requirements are different it is tried to cover this sequence with thickening time. As the step in cementation of the post expansion cement placement resemble a standard cement job in thickening time requirements the adoptions are minor.

### Static Gel Strength

The degree of shear the slurry is subjected to has a significant influence on its behavior. Under static or low shear the development of gel strength reduces the mobility of the slurry. The gel strength development at the end of the high shear period (cement placement) is a major concern for all kinds of cement jobs. Gelation can be related to the tendency of cement particles to arrange among each other to certain structures (aggregation) driven by inter-particle attraction (ionic forces) predominately in static but also under dynamic conditions of a low magnitude. The phenomenon is characterized by the gel strength representing the minimum shear strength value necessary to re-induce flow.

For most cement slurry gelation is a permanent and partially irreversible occurrence, so once gelation starts the force required to initiate flow is no longer equal to the yield stress, but to the gel strength. The gelation once manifested continues to increase until the cement becomes immobile. The minimum pressure which has to be applied to regain mobility of the slurry has to exhibit the time dependent gel strength.

If the gelation reaches a certain value known as the zero gel or fluidity time defined as the time it takes the slurry to achieve a gel strength of 100 [lbs/100 ft<sup>2</sup>]. This parameter marks the value at which, due to the loss of mobility, the slurry column starts to lose its hydrostatic



pressure incorporated with the loss of ability to balance the formation pore pressure. Over a certain period the slurry is mobile enough to allow low viscous fluids to enter the bore hole over fingering flow channels. This period ends with the development of sufficient strength to impede the development of flow channels. Within this range a high risk of losing well control and a significant reduction of cement quality can be encountered.

As mentioned earlier during the expansion process in case of pre expansion cement placement the slurry in the annulus is subjected to an extremely low periodical flow rate, initiated by the volume increase of the casing. Under these conditions the development of slurry gelation can be expected. If the gelation is too high the gel strength can't be exceeded by the low shear rate and no flow will be induced. This may lead to problems with the expansion process and would significantly reduce cement quality, so if the cement in the annulus doesn't show sufficient fluidity (above 100 [lbs/100 ft<sup>2</sup>]) during the expansion, inhomogeneous flow behaviour may cause the development of voids or bypass channels. Severe gelation incorporated with the total loss of mobility may even cause formation breakdown and a lack of zonal isolation.

To handle the problem and adjust the properties of the specific slurry in use in an accurate manner the gelation behaviour under the influence of SET cementing operations has to be investigated. For the pre expansion cement placement system the fluidity time has to cover the expansion process with sufficient safety margin.

### Compressive Strength

Cements need to develop sufficient strength to support and protect the casing against a range of different loads, but predominately against high pressure differentials causing in compressional and tensional loads in radial direction as well as loads in axial direction. In general the strength development capability strongly depends on the cement composition. So in the planning period drilling engineers have access to a wide range of cements from ultra low to high nominal final strength. But it has to be considered that the under well conditions a number of factors may influence the real cement strength.

One factor is the interaction of the cement with special additives and the resulting influence on cement properties such as strength. As the special placement procedure requires a lot of cement property adaptations, which are generally achieved by the addition of additives, the slurry design has to be performed with special caution. Due to the wide range of different additives, their individual mode of action on the targeted property and the different kind of interaction with other involved substances a general statement is almost impossible to make regarding the additive influence on slurry compressive strength designed for SEL string cementation. Especially for the operator who only has restricted access to the information about chemical and physical properties of individual products of cementation service providers.

Another factor known to influence cement slurry final compressive strength is contamination with wellbore fluids. An insufficient filter cake and mud removal (displacement) will dramatically reduce the strength capability of the cement. As it was already described above, this issue is a major concern in SEL cementation. Due to the special annular geometry and the reduced centralization capability a cement contamination is a high risk aligned with SEL cementation. To reduce the risk, once again the centralization is an issue as well as the optimization of the cement program to achieve an optimum cement placement.

### Fluid Loss

Fluid loss describes the amount of slurry mix water which is lost into the formation during the placement procedure. It is a characteristic depending on the cement placement operational, the slurry and the formation parameters. With the addition of additives the fluid loss can be



controlled which is of major importance for each kind of cementation job. High fluid losses cause the development of a cement slurry filter cake, which reduces the bond quality and might in extreme cases even cause a partial blockage of the annulus. Due to the characteristics of SET, the cement placement is of major concern and this additional aggravation has to be minimized.

Furthermore the loss of water will alter the cement slurry properties from its design characteristics. Especially thickening time, rheology, mechanical strength and gas tightness might be negatively influenced. As the thickening time requirements for SEL strings are mostly extended due to the additional operational sequences, an unexpected reduction would cause severe troubles.

For standard cementation jobs the API recommends a maximum fluid loss of 50 [cc/30min/1000psi]. For SEL cementation the experience of service companies and operators show (SPE87211) that the utilized slurry should have API fluid loss or less. Furthermore the slurry provider has to check if their retardation strategy doesn't conflict with the intended fluid loss.

### Slurry Stability

With time after passing the cement head several slurry parameters tend to vary, which might have negative influence on cement job quality. This time dependence can be observed for a bunch of parameters. In general the slurry stability is related to the free water development and solid settling. So it is related to the suspension capability of the slurry. Liquid cement must have sufficient viscosity to keep solids and liquids in suspension otherwise the free water will rise to the surface while the solids may settle to the ground. With time slurry tends to lose this suspension capability. Causing an in-homogeneity in the cementation and resulting in liquid and solid accumulations and strong viscosity variations. Furthermore the slurry stability regarding the SEL cementation is related to the long term fluidity and viscous behavior, even after intermittent flow breaks and unusual flow conditions. Consequently the slurry stability for SET applications is involved with thickening time and gel strength development.

So cement slurry needs to have excellent stability during the extended time while the SEL is expanded.

### **Cement Testing**

Cement testing procedures are a major concern in conjunction with new technological applications as SET. It is of major importance not taking the results of standardized tests without looking behind the underlying procedures. It is essential to evaluate if the test can produce representative values for the cementation job adapted for the new technology. The evaluation of parameters like compressive strength, thickening time and static gel strength has to be based on the new operational parameters (sequences).

The major cement slurry testing device is a HP/HT consistometer, which in principle consists of a rotating cylindrical slurry container, equipped with a stationary paddle assembly. The slurry filled cup is placed in a chamber to simulate the pressure and temperature conditions during the cement placement. Based on API standards the cup rotates with 150 [rpm] while the slurry consistency is measured over the torque exerted on the paddle by the cement slurry. To qualify the measurement the readings can be related to the parameters such as thickening time and gel strength.

The rheological cement testing procedure used for SEL cementation jobs is most commonly the hesitation squeeze test. It is based on temperature and pressure predictions. A time dependent PT schedule is implemented for the consistometer. The cement sample is placed in the cup and subjected to shear as predicted for the placement procedure (commonly only one speed available so not related to the real placement conditions) over the predefined

placement time. During this period temperature and pressure within the chamber are following the mentioned schedule as if the cement would be pumped down the desired well. After the cement placement was simulated the rotor is turned off, pressure and temperature are still following the predefined schedule. Now the rotor is periodically turned on for a short time interval to measure the resistance. The initial peak to introduce flow can be related to the gel strength while the stabilized resistance is related to the thickening time. After exerting a response of 70 [Bc] the thickening time is reached. The slurry is now considered to be un-pump-able,

As soon as the gel strength measurement exceeds the value of 100 [lbs/100 ft<sup>2</sup>] the fluid is considered to be completely immobile.

As already mentioned for the most common SEL applications the period during which the slurry remains mobile has to cover the expansion process. Additionally due to the different kind of operation slurry is subjected to different down-hole conditions. These conditions influence the thickening time and gel-strength development and have therefore to be considered in the measurement procedures. So especially for the period after the cement is actually pumped into the annulus some adaptations have to be considered.

After cement placement the slurry in standard cement operations would be considered to be static but in case of SET the cement is during the expansion subjected to low shear rates. A standardized HPHT consistometer is operated at 150 [rpm] which translated into shear rate would be approximately 2000 [1/s]. This rotational speed is used for periodical torque response measurements after the actual placement period. So to measure the slurry properties the fan has to be turned on for short periods to gain data. The high shear created by the paddle adulterates the gel strength development. In principle the on off cycles already simulate the expansion process but the duration and magnitude of shear has to be adapted.

A speed of 150 [rpm] corresponds to a shear which is far higher than the cement undergoes during the expansion process. Therefore the low shear created by the displacement due to SET expansion has to be evaluated and simulated with a special designed HPHT consistometer capable to be operated at extremely low rotational speeds. This device can be used to simulate the expansion process, to accurately evaluate the gel strength development as well as to simulate the thickening time.

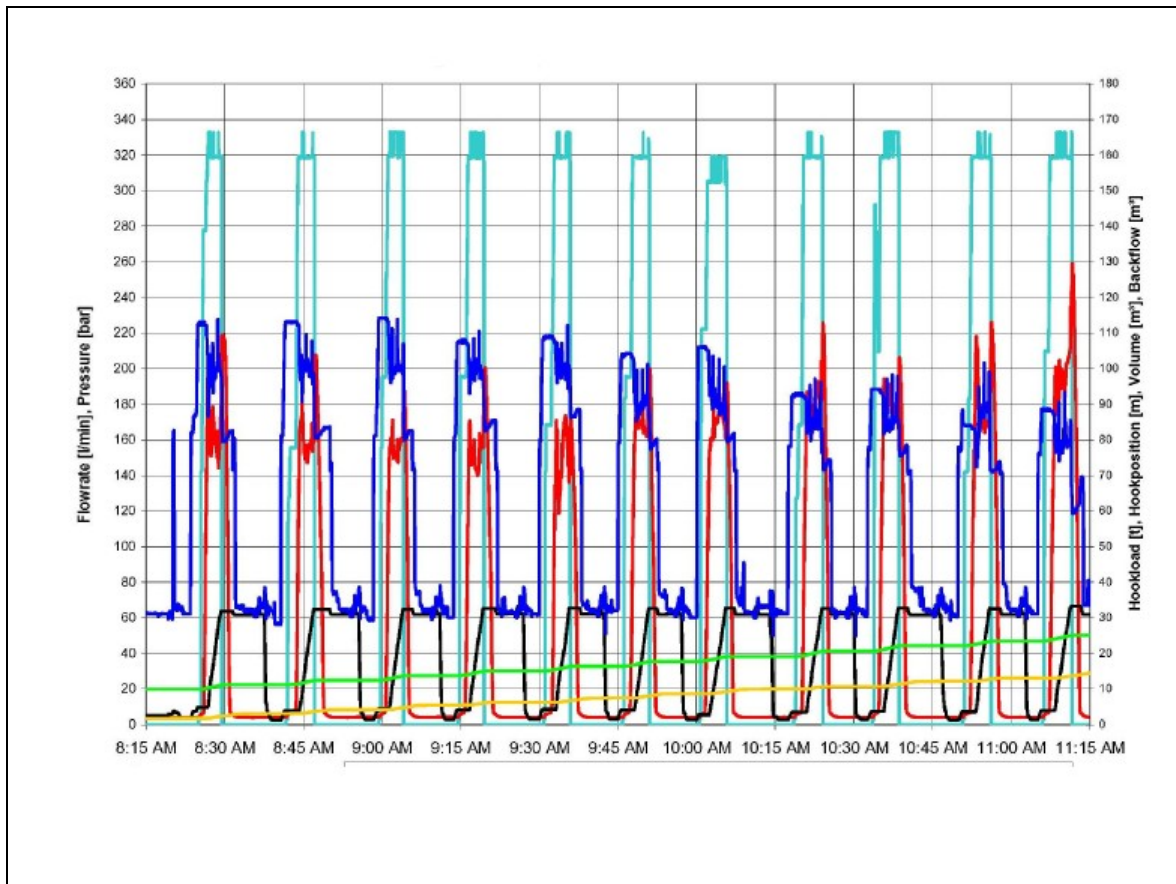

**Figure 38:** Real time data of an expansion process indicating the periodic sequence of the expansion – RWE Dea AG

So the schedule for simulating the expansion process would contain a periodically on cycles during which the paddle rotates at low speed simulating the flow induced by the annular cross section reduction caused by the expansion. One cycle should last the time required to expand the SEL over the length of one stand. After this period the paddle is turned of for the time required to brake out and stand back one stand drill pipe. This sequence is repeated to represent the entire SEL string expansion (Figure 38). Pressure and temperature schedule have to be evaluated considering the influence of the ultra low flow rate during the expansion. So during this period the temperature rises from bottom-hole circulating temperature to static following a ramp based on thermal conductivity simulations.

Conventional wellbore temperature predictions have to be taken with caution if applied for SET cementation. The API bottom-hole circulating tables and thermal recovery assumptions (API SPEC 10A) to evaluate the bottom-hole circulation temperature for cement slurry thickening time prediction, have to be adapted. Due to the extended static time (pseudo static) the course of temperature development throughout the cement job shows strong variations from the classic design approach. As the bottom-hole circulation temperature is the major factor representing the wellbore thermal recovery, which governs the thickening time of the slurry, an accurate prediction is essential for a successful SET cementation job. So a thermal recovery simulation should be performed to predict the temperature ramp for a SET cementation.

After simulating the expansion process the cement can be treated as static and the standard periodically torque measurement as described above can be used to evaluate further progress of hardening and gel-strength development.

Once again it has to be outlined that today's most commonly used hesitation squeeze test to evaluate the mobility properties of cement slurry in SEL applications, is inaccurate without the mentioned adaptations. This test already applies on of cycles to simulate the expansion, but the shear the slurry is subjected to is not representative (too high). During the high shear on cycles the slurry is continuously homogenized, especially influencing the development of gel strength.

After the accurate testing of thickening time and gel-strength the cement sample is tested for stability as free water and density segregation. As the sample was subjected to down-hole conditions more or less comparable to the real world situation, it can be assured that that results count for possible influence onto these parameters. Finally, the hardened cement sample is tested for compressive strength. Additionally to the destructive strength test, an ultrasonic cement analyzer test (UCT) should be utilized.

This non destructive ultrasonic cement strength test is performed to evaluate the time at which the onset of cement hydration is occurring. The key data points for standard cementations are the initial set defined as the time to develop a compressive strength of 50 [psi] and the time to 500 [psi]. The limit for expansion operation duration should be below the time of first indication of increased sonic speed, as this would be the statistical indication that hydration reaction have started. For the UCT test procedure an appropriate pressure and temperature schedule has to be defined. For long SET applications measurements representative for several points along the casing have to be performed.

## **Cement Preparation**

Today the industry engaged to SEL cementation recommends a pre mixed cement systems. One on hand this method allows the laboratory testing as mentioned above of the actual mixed slurry. All properties which are essentially for the success of the cement job can be physically evaluated in advance and if necessary modified with liquid additives.

Additionally, the premixing of the slurry results in a highly homogeneous consistence with long term stability. Mostly special types of suspension agents allow the long term stability and preservation of additive functionality.

## **Cement placement optimization**

It is presumed that for good cement bond and coverage (cement placement) around the pipe in the annulus a displacement of the mud and mud cake is essential. Even under optimum flow conditions with an accurately centralized pipe and the resulting flow profile it is hard to remove the entire drilling fluid residuals. The centralization conditions aligned to the SEL application aggravate this circumstance. So to achieve this goal next to the centralization optimization the cement placement and the related mud removal have to be optimized by the application of washers and spacers and the alignment of characteristics of all involved fluids.

## **Fluid design**

### **Washer**

To achieve a good displacement as well as the erosion and removal of solid residuals such as filter cake and mud pockets, both fluids the displacement and the displaced one should be in

turbulent flow conditions. As this flow behavior is almost impossible to achieve for weighted spacers and cement slurries a chemical washer should be applied. This pre-flush is intended to break and or thin the mud and filter cake in the annulus based on its chemistry and flow regime. The erosive force created by the turbulent flow breaks entrapped and bounded filter cake material. Depending on the chemistry of the filtration control materials a chemically aligned washer can additionally act as a solvent for the filter cake. This leads to dissolution of the filter cake material and an easy removal. A lower density of the flush furthermore reduces the wellbore fluid density. Due to the lower resistance to flow the weighted spacer and slurry can easily remove the light weight fluids. With the addition of water wetting agents the cement bonding can be additionally improved.

The volumetric recommendations for such washers ranging from 4 to 10 minutes of contact time (SPE87211).

As alternative to a water based chemical washer, in case of oil based mud, a base oil pre-flush can be applied which at least thin the mud and soften the filter cake.

### Spacer

As already mentioned due to the higher weight of the spacer a turbulent flow regime is hard to archive nevertheless the spacer should be pumped with the maximum possible flow rate to improve mud removal. The actual displacement capability of the spacer is based on the combined effect off density and yield strength differential. The spacer should always be heavier than the mud to downright lift the mud out of the annulus. This Involvement of the buoyancy effect requires a density differential of at least 0,5 [ppg] (SPE 872111).

The yield strength differential between the displaced and the displacement fluid further improves the removal. The yield point/strength characterizes the fluids initial resistance to flow. If the yield point of the mud is below the yield point of the spacer the interface between both fluids is flattened enhancing the displacement efficiency. It further prevents from channeling of the spacer through the mud. To utilize this effect a yield point differential of 10 [lbf/100ft<sup>2</sup>] is recommended (SPE 872111).

### Slurry

Both property adjustments applied to the spacer will be continued for the slurry design. So additionally to the property adaptations described above the cement slurry has to exceed the density as well as the yield strength of mud and spacer. The density of the slurry is anyhow higher than of all other present wellbore fluids.

Furthermore the slurry yield point should always be at least 10 [lbf/100ft<sup>2</sup>] higher than that of the mud, while the yield of the spacer should range in between. This adaption allows formation of a stable and flat interface respectively velocity profile between the individual profiles significantly improving the placement efficiency even in poorly centralized annular sections.

But on the other hand it has to be kept in mind that the yield strength represents the initial resistance of a fluid to flow, so with further increases the velocity to initiate flow in the narrow parts of the well might be too high. As a result the mud would again be diverted away from the low side of the annulus. As a consequence slurry yield should not exceed 30 [lbf/100 ft<sup>2</sup>].

Furthermore the initial yield strength as well as the shear dependent viscosity determines the rheological flow behaviour. So for a long time it was suggested that these parameters have to be kept as low as possible to achieve turbulent flow. But due to the nature of cement slurry of high density and high viscosity it is anyhow almost impossible to gain turbulent flow. But

nevertheless as the essential factor is the yield strength differential the absolute value should be kept as low as possible as long as an adequate differential is adhered.

# Standoff Simulation of SEL Strings

## SEL Operation Range base on Centralization

### Simulation - Objectives

The simulation comprises the evaluation of liner standoff, for two different types of commercially deployed SEL systems. Both system designs offer the possibility to utilize specially developed centralizers to improve pipe standoff, compared to the SEL application without centralization.

For the initial simulation the average SEL standoff is evaluated for a range of different but uniform inclined tangent sections, with and without centralizer utilization. For each reviewed inclination the hole-quality is varied within a predefined range based on observations made in actual and potential application areas as well as on literature recommendations. Furthermore several different spacings are simulated in case of centralizer deployment.

The output allows the generation of a SEL standoff matrix for each single inclination over a range of different hole-qualities without centralizer deployment and with different spaced centralizers installed.

In the second part of the simulation the real life data of an existing SEL application is used to simulate the standoff with and without centralization for a measured survey and hole-quality. A range of different individualized spacings will be implemented.

In the previous chapter standoff was identified, based on literature research and an examination of the processed case studies as one of the major factors influencing the cement job quality. As a general cognition it can be mentioned that as higher the standoff (high degree of centralization) achieved as more efficient reliability and quality of the pipe cementation.

Especially due to the enhanced flow behavior through a more symmetric annular cross-sectional area, hole-cleaning and filter cake removal as well as mud displacement and slurry placement are improved quantitatively and qualitatively.

So far it was hardly possible to centralize expandable pipes. Conventional centralizers have not been designed to undergo a pipe diameter increase. Furthermore due to limitations in expansion rate the annular clearance along the preliminary pipe sections strongly restricts the thickness of centralization devices during the SEL running procedure.

New centralizer designs allow an installation on expandable pipes capable to stand the expansion process while maintaining or developing their centralization capability during the expansion. To quantify the impact of this new technology on achievable standoff for SEL systems available, the mentioned simulation will be performed via Halliburton's "Wellplan" simulation and planning software.

The evaluation of an average pipe standoff across the entire string allows the comparison of SEL application with and without centralization for different inclinations over a range of hole-qualities and centralizer installation parameters. Furthermore the quantitative effect of centralizer installation for the single SEL designs will be evaluated and checked for sufficiency to reach the standardized standoff values recommended by the API. This benchmark is valid to be necessary to achieve an adequate cementation quality. If a minimum standoff demand based on API recommendations or on individual considerations is defined the matrix can be used to appraise an application area for the solid expandable application.

As the development of a general admitted matrix requires several generalizations and simplifications regarding the specification of SEL installation operation and wellbore specifications, an additional simulation with real life log data will be performed for a single

case. The simulation will be used to optimize the standoff values utilizing all adjustable parameters and evaluating the best alignment for the single parameters to achieve an optimum result.

### **Simulation - Base Case**

For the creation of representative base case all characteristics and parameters are based on information gained from the examination of the SEL applications described in the previous chapter as well as other wells drilled by the same operator within the same geological structures but without SEL application. Furthermore all information and applied parameters are aligned with literature information.

### **Wellbore**

As target section a 3300 [ft] open-hole sections was implemented. The intention is to seal of a open hole section over 3281 [ft] with an solid expandable liner of an equivalent drift to a conventional 9 5/8 [in] liner, extending the SEL technology to its limits. For both SEL products simulated the open-hole diameter requirements have been evaluated and feed into the software (Table 04). The well-path of the open-hole is based on a tangent section with a constant inclination and azimuth value over the entire examined section. To simulate a wide range of different well path designs eight inclinations between 15 [°] and 85 [°] with 15 [°] increments have been simulated. Additionally a vertical and a horizontal section have been examined. For all inclinations different to 0 [°] the azimuth is kept constant at 270 [°].

| <b>Enventure SEL System</b>       | <b>Baker SEL System</b>           |
|-----------------------------------|-----------------------------------|
| <i>Open-Hole Length</i>           |                                   |
| 3300 [ft]                         |                                   |
| <i>Nominal Open-Hole Diameter</i> | <i>Nominal Open-Hole Diameter</i> |
| 9,875 [in]                        | 10,25 [in]                        |

**Table 04:** *Open-Hole specifications*

As for a typical 9 5/8 [in] hole-section a tortuosity can be expected, the surveys of the reverence wells out of RWE-Dea database have been checked for unsteadiness. As the number of reverence wells with SEL applications was limited additional wells with comparable operational and environmental parameters have been used to analyze tortuosity. A strong inclination dependence of tortuosity was recognized. As the strong irregularities in tortuosity couldn't be implemented due to software limitations only typical amplitude and frequency values of inclination and azimuth variations have been evaluated and implemented as a sinus wave to the planed simulation survey (Figure 39-44; Table 05). Three different profiles have been defined for the vertical, slanted and horizontal well path and kept constant for the entire simulation.



| Open-Hole Tortuosity            |               |                   |                                 |               |                   |
|---------------------------------|---------------|-------------------|---------------------------------|---------------|-------------------|
| Tangent Section Inclination [°] | DLS (°/100ft) | AbsTort (°/100ft) | Tangent Section Inclination [°] | DLS (°/100ft) | AbsTort (°/100ft) |
| 0                               | 0,30          | 0,06              | 55                              | 0,71          | 0,81              |
| 15                              | 0,58          | 0,30              | 65                              | 0,75          | 0,94              |
| 25                              | 0,61          | 0,42              | 75                              | 0,77          | 1,07              |
| 35                              | 0,64          | 0,55              | 85                              | 0,78          | 1,20              |
| 45                              | 0,68          | 0,68              | 90                              | 1,00          | 1,30              |

**Table 05:** Open-Hole tortuosity and dogleg specifications

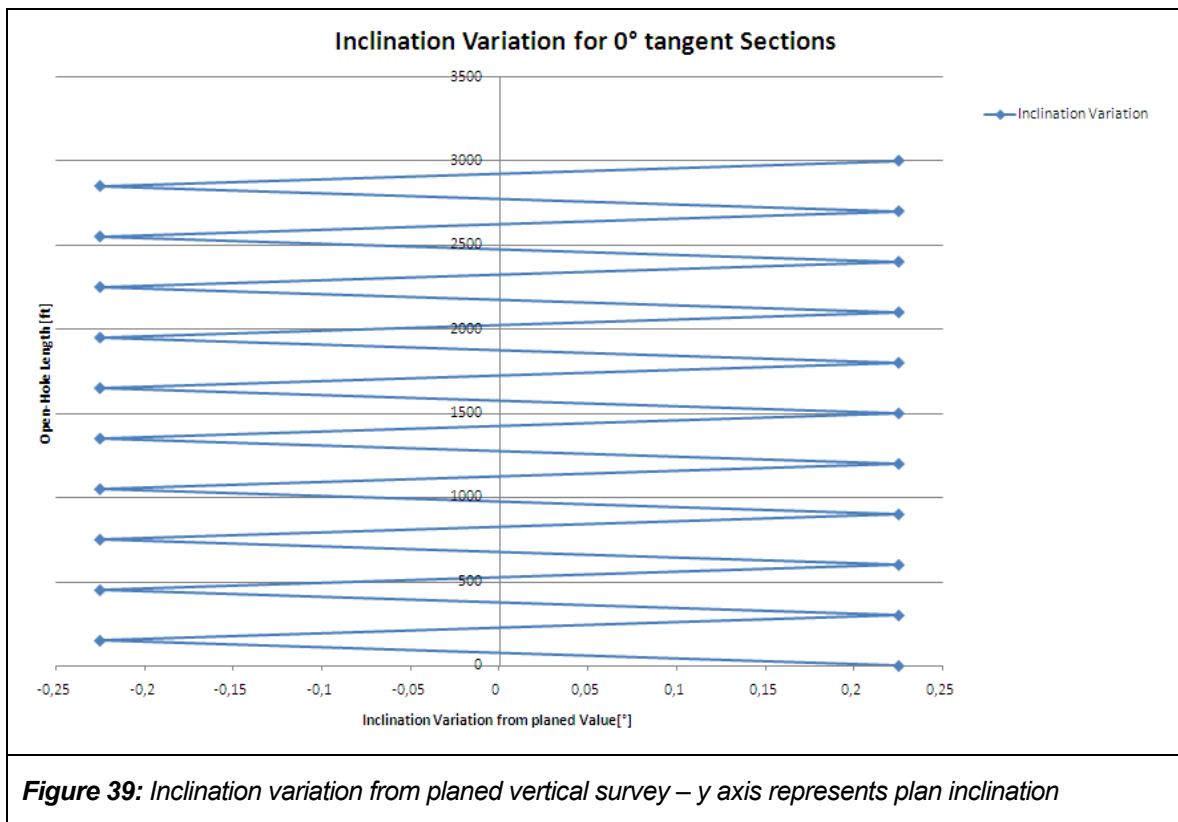

**Figure 39:** Inclination variation from planed vertical survey – y axis represents plan inclination

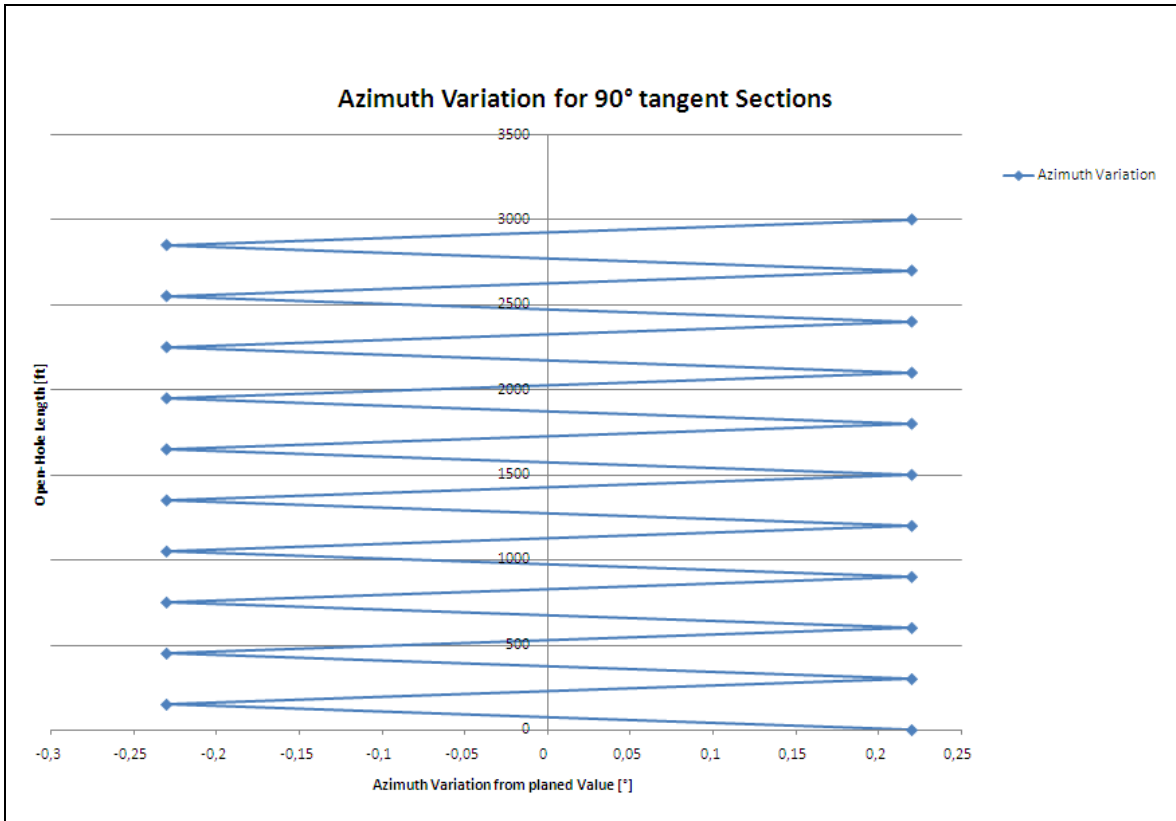

**Figure 40:** Azimuth variation from planed vertical survey – y axis represents plan azimuth

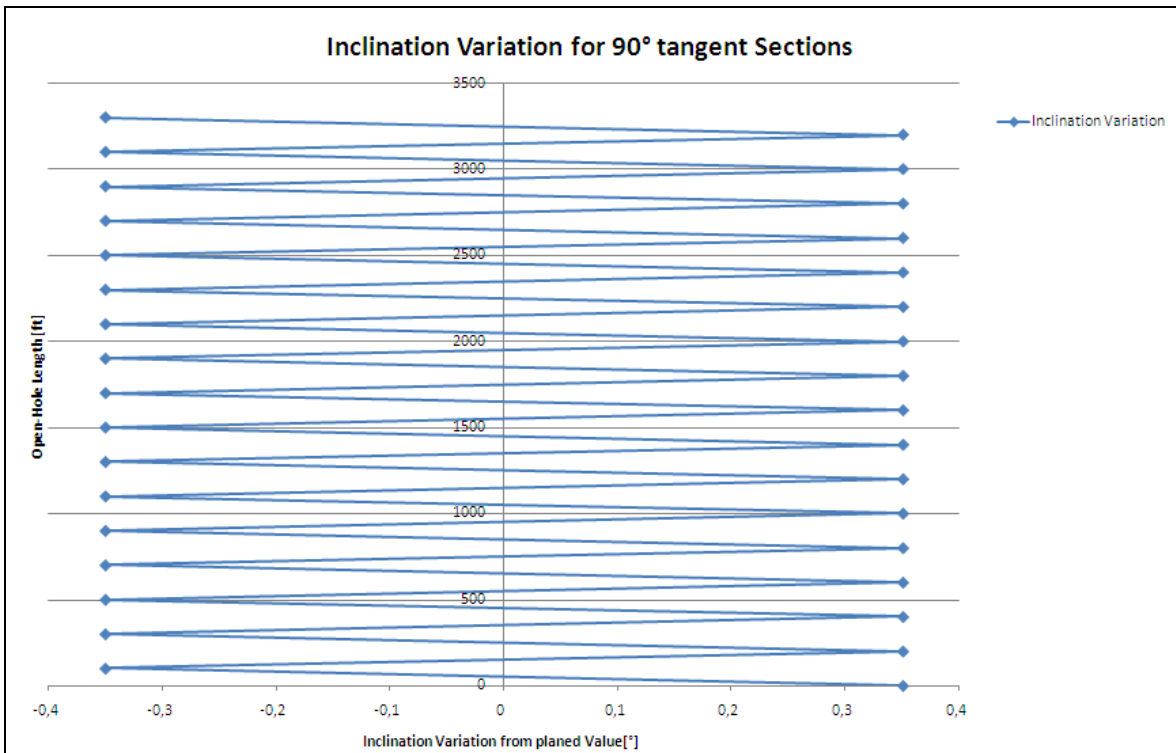

**Figure 41:** Inclination variation from planed horizontal survey – y axis represents plan inclination

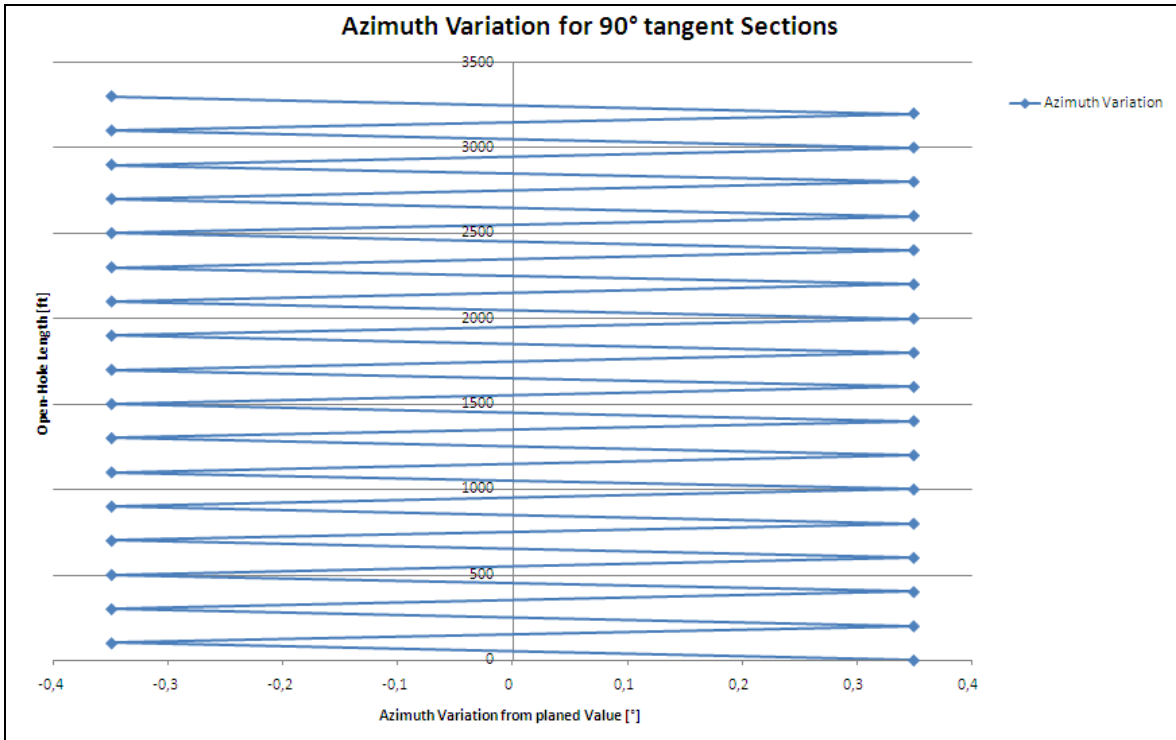

**Figure 42:** Azimuth variation from planned horizontal survey – y axis represents plan azimuth

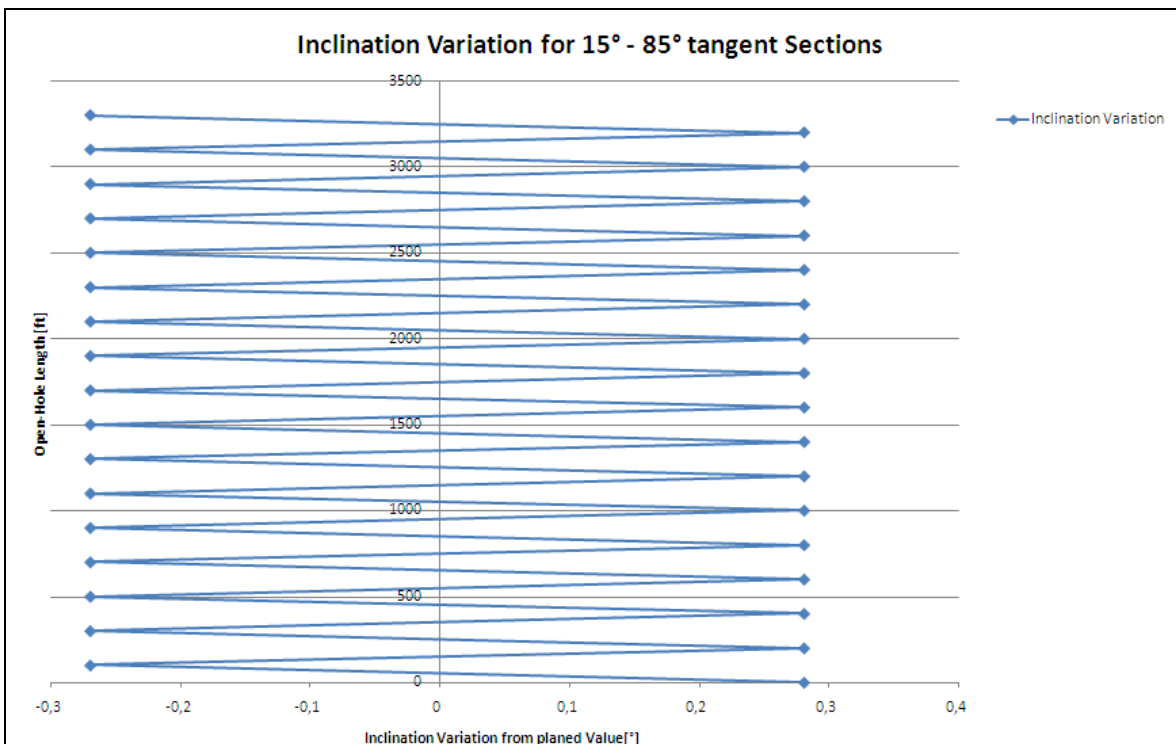

**Figure 43:** Inclination variation from planned inclined surveys – y axis represents plan inclination

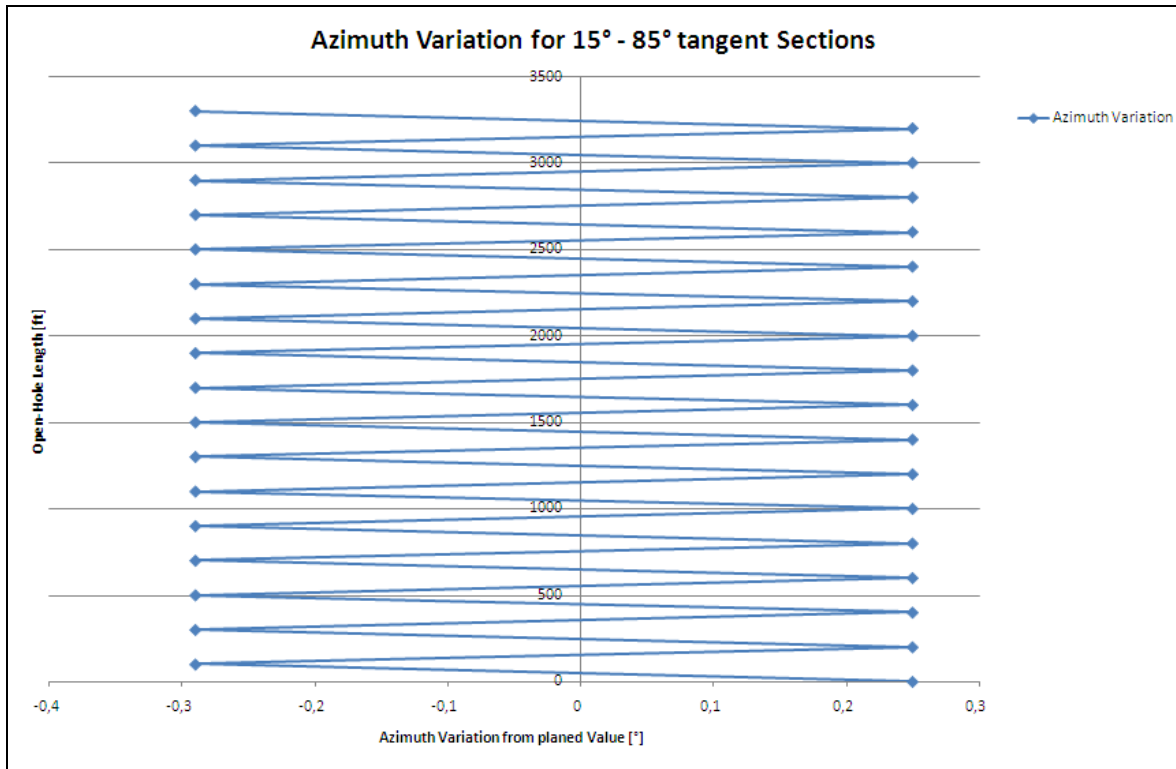

**Figure 44:** Azimuth variation from planed inclined surveys – y axis represents plan azimuth

As a full gauged hole will hardly be achieved and irregularities in open-hole shape and size do have an significant influence on pipe standoff hole quality is an important consideration in case of standoff simulation. Due to operational and environmental circumstances, complex shape variations from the idealized circular profile have to be presumed. This is confirmed by log measurements in several reference wells.

But as the utilized software is not able to handle these complex geometries a simplified way to consider the hole-quality had to be found. As the hole-size irregularities in the examined reference wells show an explicit tendency for an increased volumetric capacity, total open-hole volume increases between 5 [%] and 25 [%] with 5[%] increments have been investigated. Those values are based on measurements made in several reference wells. To implement these values into the software the volumetric increases are converted to effective open-hole diameters (Table 06).

| <b>Enventure SEL System</b>              |  |
|--|--|
| <i>Open-Hole Volumetric Increase [%]</i> | <i>Effective Open-Hole Diameter [in]</i> |
| 0  | 9,875                                    |
| 5  | 10,119                                   |
| 10                                       | 10,357                                   |
| 15                                       | 10,59                                    |
| 20                                       | 10,817                                   |
| 25                                       | 11,04                                    |
| <b>Baker SEL System</b>                  |  |
| <i>Open-Hole Volumetric Increase [%]</i> | <i>Effective Open-Hole Diameter [in]</i> |
| 0  | 10,25                                    |
| 5  | 10,503                                   |
| 10                                       | 10,75                                    |
| 15                                       | 10,992                                   |
| 20                                       | 11,228                                   |
| 25                                       | 11,46                                    |

**Table 06:** Equivalent Open-Hole diameters to specify hole quality variations

## **SEL-String**

As already mentioned two representative SEL techniques have been chosen for the simulation. Both techniques are following different design approaches as explained in detail in the previous chapters. Although the entire installation operation differs significantly it has to be kept in mind that the aimed target is the same. The intention is to extend a 9 5/8 [in] casing section over a predefined length by preserving the inner diameter. Furthermore a high quality cementation has to be achieved across the pipe extension.

### Enventure SEL System

The enventure SEL system (Table 07) was simulated for all predefined well conditions and profiles with and without centralizers installed. The primary characteristic of the product design regarding cementation optimization is the pre-expansion slurry placement. As the entire preconditioning and cement program is pumped preliminary the expansion process the main interest is the centralization in the pre-expanded pipe condition. The slurry behavior within the annulus during the expansion process is hardly investigated so far. Although the degree of contribution is not investigated so far it seems to be obvious that the slurry displacement due to the annular clearance reduction improves the slurry distribution. Due to this reason the string pre- and post-expansion standoff has been simulated.

| Enventure SEL String |         |     |                      |         |     |
|----------------------|---------|-----|----------------------|---------|-----|
| SET - Pre-Expansion  |         |     | SET - Post-Expansion |         |     |
| OD                   | 7,625   | in  | OD                   | 8,427   | in  |
| ID                   | 6,875   | in  | ID                   | 7,71    | in  |
| Weight               | 29,7    | ppf | Weight               | 30,88   | ppf |
| Grade                | EX-80   | -   | Grade                | EX-80   | -   |
| Length               | 3564,44 | ft  | Length               | 3564,44 | ft  |
| Launcher OD          | 8,375   | in  | Launcher OD          | 8,375   | in  |
| Launcher-Length      | 4,6     | ft  | Launcher-Length      | 4,6     | ft  |

**Table 07:** Enventure SEL string specifications

For the Enventure SEL system the service contractor approved special designed rigid centralizers (Table 08) (detailed description in previous chapter). The technology is available in multiple shapes and materials. The maximum available diameter for the centralizer sub under pre expansion conditions and therefore the plate thickness of the centralizer element is limited by the drift diameter of the base casing. It is assumed for post expansion condition that the change in centralizer plate geometry is minor, without showing significant influence onto the centralization capabilities.

| Centralizer          |       |    |                      |       |    |
|----------------------|-------|----|----------------------|-------|----|
| Pre Expansion        |       |    | Post Expansion       |       |    |
| Type                 | Rigid | -  | Type                 | Rigid | -  |
| Ref. Casing Diameter | 7,625 | in | Ref. Casing Diameter | 8,427 | in |
| Hole Diameter        | 9,875 | in | Hole Diameter        | 9,875 | in |
| Nominal Diameter     | 8,625 | in | Nominal Diameter     | 9,427 | in |
| Length               | 15    | in | Length               | 15    | in |
| Number of Bows       | 3     | -  | Number of Bows       | 3     | -  |

**Table 08:** Specifications of SEL centralizers recommended by Enventure

As an accurate spacing is the only primary centralization capability influencing factor that the system allows to alter, a wide range of different spacings have been investigated. Therefore four spacings between 15 [ft] to 60 [ft] have been chosen with 15 [ft] increments. Additionally, 18 [ft], 36 [ft] and a 72 [ft] spacings have been chosen as these distances allows an easier operational installation on the most commonly used 36 [ft] liner joints. All spacings have been applied for the entire range of hole-qualities for the pre and post expanded pipe.

As buoyancy plays an important role the fluid column within the annular space and the string had to be defined (Table 09). As the fluid densities strongly depend on the individual wellbore conditions the fluid densities are based on the 9 5/8 [in] target structures of the examined reference wells. The fluid column length is designed to reach the maximum allowable cement length in the post expansion state.

| <b>Cement Program</b>            |                      |                       |
|----------------------------------|----------------------|-----------------------|
|                                  | <i>Pre Expansion</i> | <i>Post expansion</i> |
| String Length in OH [ft]         | 3264                 | 3264                  |
| Cement Column Length [ft]        | 1826                 | 2710                  |
| Cement Column Density [ppg]      | 15,8                 | 15,8                  |
| Spacer Column Length [ft]        | 262                  | 388                   |
| Spacer Column Density [ppg]      | 12,5                 | 12,5                  |
| Mud Length [ft]                  | 1172                 | 166                   |
| Mud Density [ppg]                | 11,3                 | 11,3                  |
| Displacement Fluid Density [ppg] | 11,3                 | 11,3                  |

**Table 09:** Cement Program implemented in Standoff simulation

### Baker SEL System

The primary characteristic of the baker SEL system (Table 10) is the cement placement after the expansion process. The entire conditioning and slurry program is pumped post-expansion. As a result the degree of centralization of the pre-expanded pipe doesn't influence the cementation quality. This fact was also considered as a special centralizer was developed, that gains his centralization capability primary with the expansion process. The centralization device doesn't contribute to the pipe standoff in pre-expanded condition. Consequently the standoff of the SEL string with centralizer installations equals the non centralized string.

| <b>Baker SEL String</b>    |         |     |                             |         |     |
|----------------------------|---------|-----|-----------------------------|---------|-----|
| <i>SET - Pre-Expansion</i> |         |     | <i>SET - Post-Expansion</i> |         |     |
| OD                         | 8       | in  | OD                          | 9,287   | in  |
| ID                         | 7,31    | in  | ID                          | 8,675   | in  |
| Weight                     | 28,2    | ppf | Weight                      | 29,33   | ppf |
| Grade                      | L-80    | -   | Grade *(3)                  | L-80    | -   |
| Length                     | 3294,44 | ft  | Length                      | 3294,44 | ft  |

**Table 10:** Baker SEL string specifications

To centralize the SEL special designed bow type centralizers (Table 11) have been applied as described in the previous chapter. The centralizer was implemented for the same spacings as described for the Enventure system but only simulated for the post expanded pipe as it doesn't contribute to the pre- expansion pipe standoff.

| <b>Centralizer</b>    |        |     |
|-----------------------|--------|-----|
| <i>Post Expansion</i> |        |     |
| Type                  | Bow    | -   |
| Ref. Casing Diameter  | 9,287  | in  |
| Hole Diameter         | 10,25  | in  |
| Nominal Diameter      | 11,375 | in  |
| Minimum Diameter      | 9,287  | in  |
| Length                | 27,88  | in  |
| Number of Bows        | 7      | -   |
| Restoring Force       | 2150   | lbf |

**Table 11:** Specifications of SEL centralizers recommended by Baker

The Cement program (Table 12) for the Baker SEL system is based on the same parameters as the program designed for the Enventure SEL system. In the pre-expanded state an equal fluid density within string and annulus is assumed for the entire simulated section.

| <b>Cement Program</b>            |                      |                       |
|----------------------------------|----------------------|-----------------------|
|                                  | <i>Pre Expansion</i> | <i>Post expansion</i> |
| String Length in OH [ft]         | 3264                 | 3264                  |
| Cement Column Length [ft]        | -                    | 2710                  |
| Cement Column Density [ppg]      | -                    | 15,8                  |
| Spacer Column Length [ft]        | -                    | 547                   |
| Spacer Column Density [ppg]      | -                    | 12,5                  |
| Mud Length [ft]                  | 3264                 | 7                     |
| Mud Density [ppg]                | 11,3                 | 11,3                  |
| Displacement Fluid Density [ppg] | 11,3                 | 11,3                  |

**Table 12:** Cement Program implemented in Standoff simulation

## **Calculation Approach**

For the evaluation of a standoff profile across the examined liner section Halliburton's "Landmark" software package was utilized. The "Wellplan" program, as part of the package via the "OptiCem" module, allows the direct calculation of a standoff profile, as long as centralization devices are implemented across the analyzed string. For the standoff evaluation of a non centralized string the "Torque and Drag" module had to be utilized. The module allows the calculation of the pipe position within the wellbore. These output data can be converted to a standoff profile based on simple geometric considerations. For the creation of the standoff matrix an arithmetic average value was calculated for each single standoff profile (Figure 45).



The software was used as it is one of the market-leading planning and simulation software for drilling engineering and it is implemented in the work process of several oil companies worldwide such as RWE-Dea.

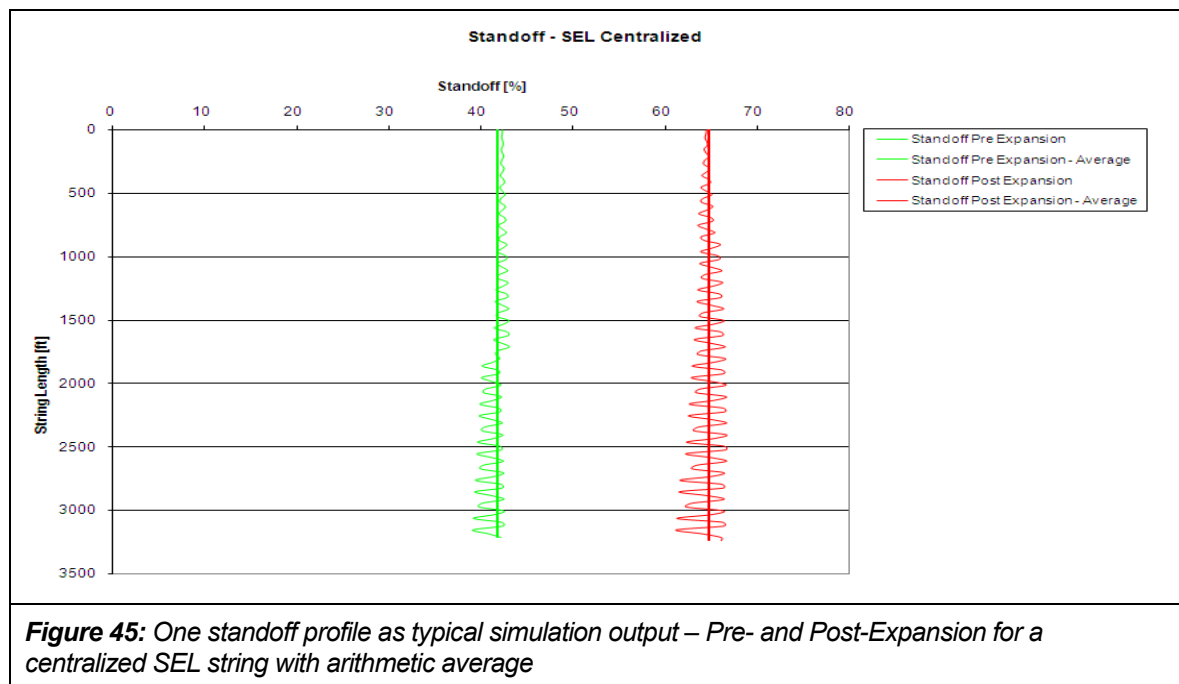

## Centralized SEL Pipe

The underlying calculation approach is based on analytical computations allowing the evaluation of a standoff profile across the examined section. The primary prerequisite is the implementation of at least two centralizers across the entire string length. As the standoff calculation approach is based on the examination of pipe sections between two centralization devices.

The base position of the string is related to a “soft string model”, which ignores any tubular stiffness effects. This means that the pipe is treated as a heavy cable, chain or rope lying along the wellbore wall. The model suggests that the string doesn’t provide any resistance against bending. So as soon as the tangential forces higher than zero acting upon the string the pipe is pushed against the wall in the direction of the applied force. Under the resulting conditions the string will always rest on the wellbore wall as soon as any inclination higher than 0 [°] is applied as the tangential forces start to appear. For a perfect vertical well the string should theoretically be exactly centralized within the hole.

But nevertheless for simplification reasons the software always assumes a non centralized string even under vertical conditions, which runs along the wellbore wall. So as long as no centralizers are applied it displays a standoff of 0 [%] for all trajectory design options, even perfect vertical.

With the implementation of centralizers points of fixed standoff are created. Each centralizer is in contact with the wellbore wall and lifts the pipe of (Figure 46). The amount of pipe deflection at the centralizer point depends, for rigid type centralizers exclusively on centralizer geometry as a solid centralizer is assumed to be incompressible. For bow type centralizer it depends on the balance between evaluated tangential force and the restoring force (see centralizer specification) which is related to the flexibility of the bow spring.

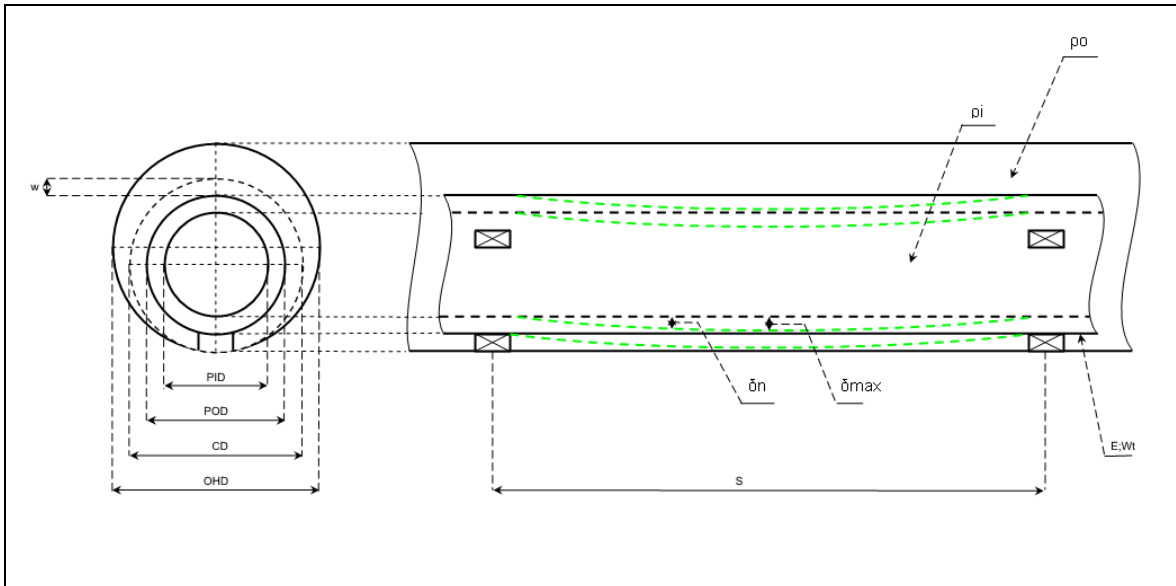

**Figure 46:** Schematic of one pipe segment between two centralizers [PID-Pipe Inner Diameter; POD-Pipe Outer Diameter; CD-Centralizer Diameter; OHD-Open Hole Diameter; Wt-Pipe Weight per Unit Length; E-Pipe Young's Modulus;  $\delta_n$ -Sag Profile;  $\delta_{max}$ -Maximum Sag;  $\rho_i$ -Liquid Density inside the Pipe;  $\rho_o$ -Liquid Density outside the Pipe;  $w$ -Lift-off at Centralizer;  $S$ -Centralizer Spacing] – P. Fischer

Each section between the two centralizers is now handled like a straight beam (Figure 47), with a cross-sectional area of a circular ring with the related momentum of inertia and material properties as entered in the simulation (see string specification). The section bends under the tangential force calculated via Equation 19-20. The utilized approach for bending force evaluation for each individual element depends on well path, the subsequent section load and the buoyant weight of the string section. Each individual sag profile is following the bending line based on fixed end criterion (Equation 17-18).

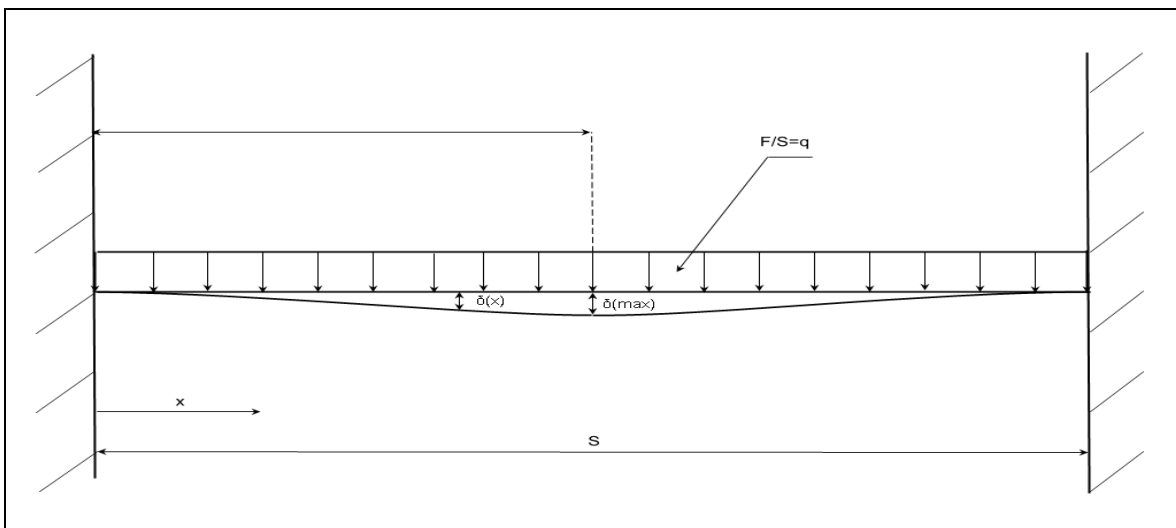
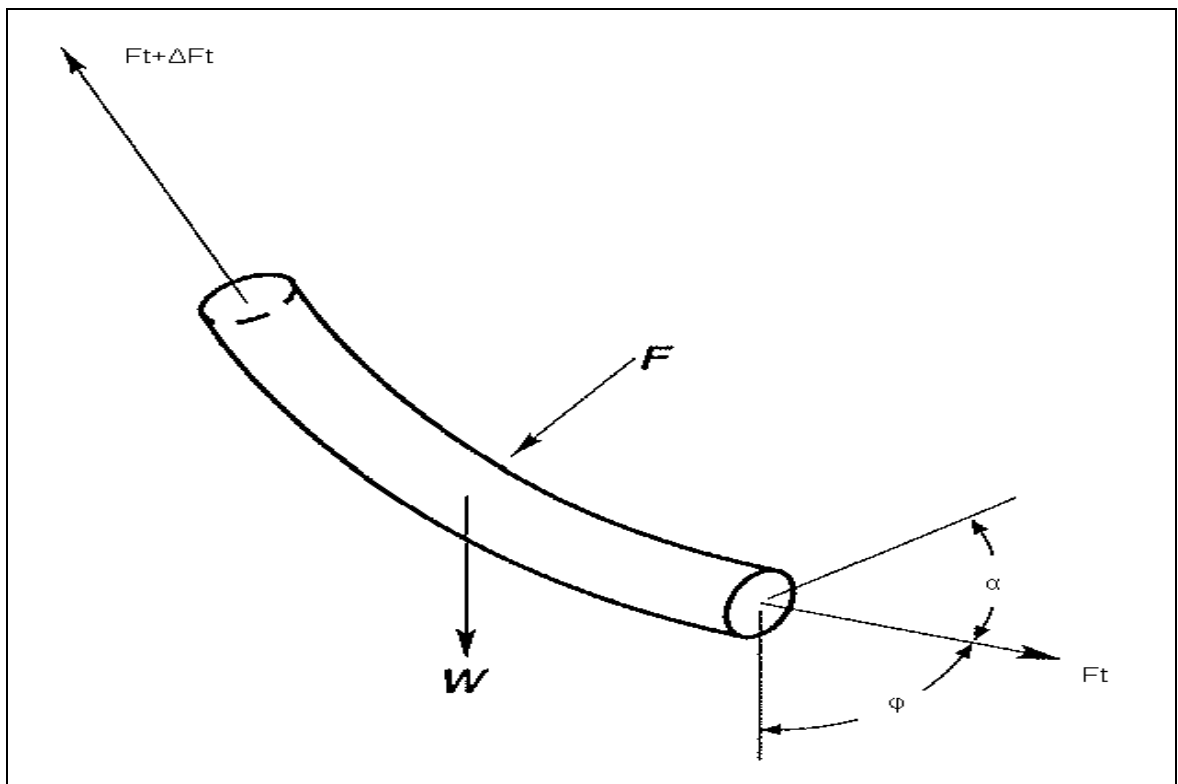

**Figure 47:** Idealized beam section with boundary criteria [ $\delta(x)$ -Sag Profile;  $\delta_{max}$ -Maximum Sag;  $S$ -Centralizer Spacing;  $F$ -Tangential Force – P. Fischer

|   |                                       |
|---|---------------------------------------|
| $\delta_{(x)} = \frac{q * S^4}{24 * E * I} * \left[ \left( \frac{x}{S} \right)^2 - 2 * \left( \frac{x}{S} \right)^3 + \left( \frac{x}{S} \right)^4 \right]$ | F/S=q..... Side-Force per unit length |
|   | E..... Young's Modulus                |
|   | S..... Section-Length (Spacing)       |
|   | I..... Pipe momentum of inertia       |
|   | $\delta(x)$ ..... Sag profile         |

|  |                                 |
|--|---------------------------------|
| $\delta_{(max)} = \frac{q * S^4}{E * I} * \frac{1}{384}$ | $\delta(max)$ ..... Maximum sag |
|  | E..... Young's Modulus          |
|  | S..... Section-Length (spacing) |
|  | I..... Pipe momentum of inertia |

**Equation 17-18:** Sag Profile and maximum Sag based on fixed end criterion – S. Robello Halliburton



**Figure 48:** Schematic of model for the evaluation of the tangential forces used to calculate the section sag - Petroleum Well Construction, Michael J. Econmides et. al.

|  |  |
|--|--|
| $F = \sqrt{(F_t * \Delta\alpha * \sin(\varphi_{aver.}))^2 + (F_t * \Delta\varphi + W * BF * \sin(\varphi_{aver.}))^2}$ |  |
| F.....   | Tangential force                       |
| Ft.....  | Axial-Force of the subsequent sections |
| $\Delta\alpha$ .....   | Change in azimuth                      |
| $\Delta\varphi$ .....  | Change in inclination                  |
| $\varphi_{aver}$ .....   | Average inclination over on section    |
| W.....   | Weight force                           |
| BF.....  | Buoyancy Factor                        |

|  |                |                                  |
|--|----------------|----------------------------------|
| $BF = \frac{\left(1 - \frac{\rho_o}{\rho_s}\right) - \left(\frac{PID}{POD}\right)^2 * \left(1 - \frac{\rho_i}{\rho_s}\right)}{1 - \left(\frac{PID}{POD}\right)^2}$ | $\rho_o$ ..... | Fluid density within the annulus |
|  | $\rho_i$ ..... | Fluid density inside the pipe    |
|  | $\rho_s$ ..... | Pipe steel density               |
|  | PID.....       | Pipe inner diameter              |
|  | POD.....       | Pipe outer diameter              |

**Equation19-20:** Model for the evaluation of the tangential forces used to calculate the section sag

At the point of maximum sag the pipe liftoff from the wellbore wall is at its minimum. At this point the distance from the wellbore wall is used to evaluate a standoff value (Equation 21-22) which is considered to be representative for the entire section between two centralizers (Figure 49). The number of sections is governed by the number of centralizers applied. As one standoff value is calculated for each section a standoff profile is created over the entire length of the SEL string (Figure 45). For the implementation into the standoff matrix the arithmetic average of the profile values is calculated.

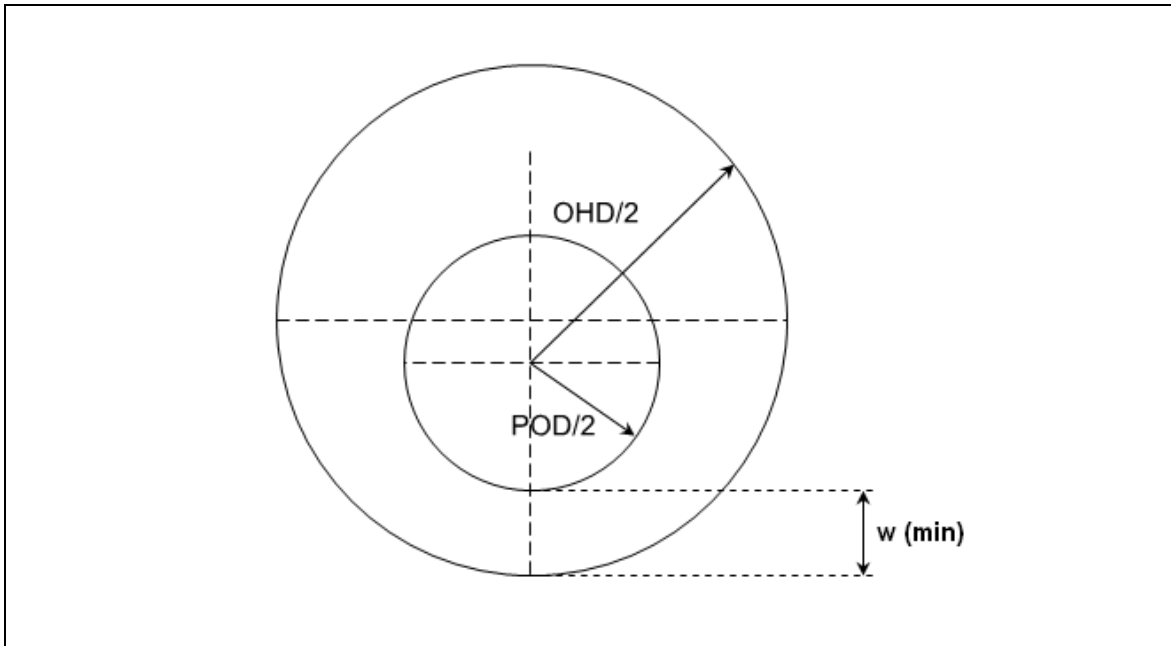

**Figure 49:** Pipe body distance from wellbore wall at maximum sag – P. Fischer

|                                  |  |
|----------------------------------|--|
| $w_{(min)} = w - \delta_{(max)}$ | w..... Minimum distance of pipe body from wellbore wall at centralizer   |
|                                  | w (min)..... Minimum distance of pipe body from wellbore wall at max sag |
|                                  | δ (max)..... Maximum sag   |

|   |                                       |
|---|---------------------------------------|
| $S = \frac{(w_{(min)})}{(OHD/2 - POD/2)} * 100$ | S..... Standoff value for one section |
|   | OHD..... Open-Hole diameter           |
|   | POD..... Pipe outer diameter          |

**Equation 21-22:** calculation approach used to evaluate Standoff at point of maximum sag

**Non Centralized SEL Pipes**

To gain representative standoff values for SEL applications without centralizers installed the “OptiCem” module of “Wellplan” software showed to be insufficient. As already explained above the underlying calculation approach assumes that each non centralized string follows with a standoff of zero each trajectory design regardless of any irregularities. Only after the implementation of centralizers, points of fixed standoff are created acting as a base for the further calculations. This fact precludes the approach for standoff evaluation of non centralized pipes. The software always assumes a standoff of zero for non centralized strings.

Due to several issues this assumption can be considered to be at least inaccurate. Even in inclined well-profiles it string will not rest over the entire length on the wellbore wall.

As already described in the string specifications both SEL string designs use over gauged connection sleeves. Although the related deflection is low it produces at least a minimum standoff. Furthermore due to unavoidable irregularities of the wellbore survey and the high stiffness of a liner pipe, it is self evident that the pipe is not continuously in contact with the wellbore wall.

As the “OptiCem” module is based on a “soft string model” and therefore only accounts for stiffness after implementation of centralizers, an approach which in general accounts for pipe stiffness have to be found to evaluate the SEL standoff. Several options have been evaluated but due to the fact that only a few commercially deployed software solutions for standoff calculations are actually available and as most of them are based in the same calculation approach as “OptiCem” no direct way for the calculation could be investigated. But as the necessary stiff string model is already utilized by “Wellplan” software for torque and drag calculations, it was tried to find a way to evaluate the SEL pipe standoff without centralizers installed using the torque and drag module.

Within this module the program allows the evaluation of the string position for different operations (Tripping-In; Tripping-Out; Rotating On-bottom; Rotating Off-bottom). As the intention is to evaluate the pipe position for a static string, the axial and rotational speeds as well as stand up weight are set to be zero. As a result no dynamic frictional forces are acting upon the string. The resulting conditions describe a static string off bottom, which is continuously under tension.

For the position evaluation the software subdivides the string in 31 [ft] elements bounded by two nodes (tool joints) and traverses the string from bottom to top (trip in) or top to bottom (trip out). For each section it computes the side force at center point to evaluate the position, based on the bending of the section.

The delayed analysis of each individual node involves creating a mesh of 10 to 20 elements (nodes) ahead of the processed node in traverse direction. The front end node is assumed to be in the center of the hole, while the node behind the currently processed node is fixed at the position evaluated in the previous step. With the accurate evaluation of the processed node the mesh progresses in the traverse direction to evaluate the next node (Figure 50).

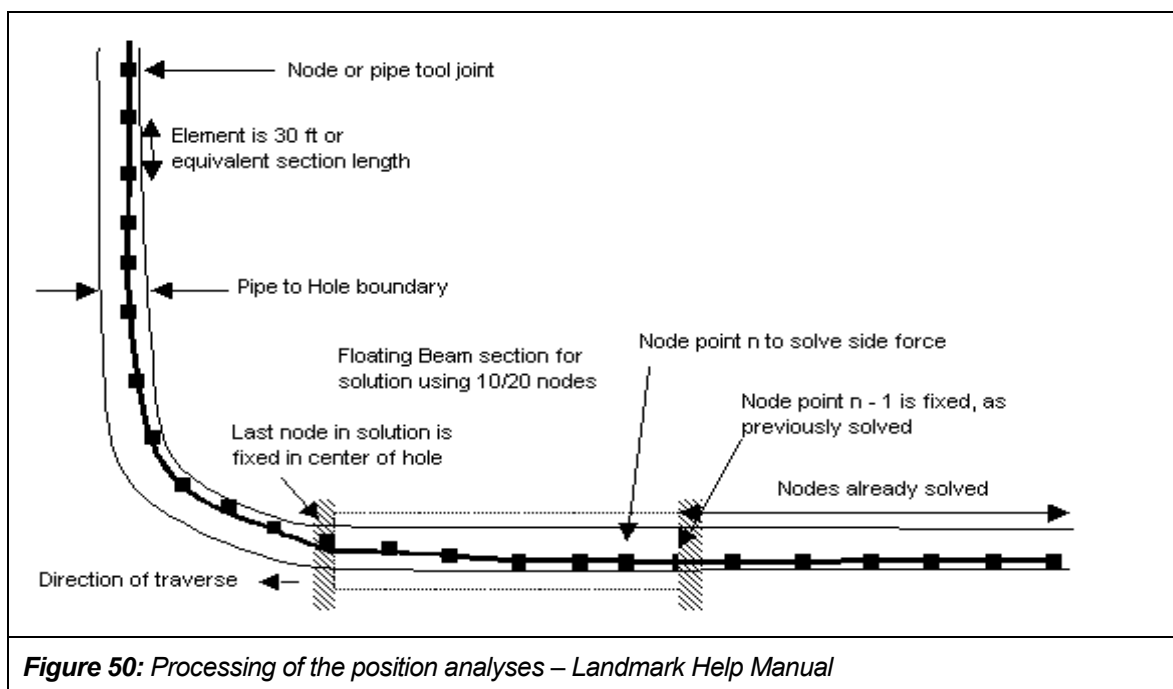

**Figure 50: Processing of the position analyses – Landmark Help Manual**

The software produces two position lines (high position; right position) outlining the position of the pipe (with an outer radius (r)) inside the wellbore (with the radius (R)). The high position indicates the pipe position relative to the high-side (+z) or low-side (-z) of the hole (i.e. tool-face 90-270 [°]). The right position indicates the pipe position relative to the left-side (-y) or right-side (+y) of the hole (i.e. tool-face 0-180 [°]). Based on simple geometrical considerations (Figure 51; Equation 23-24) the minimum distance between pipe wall and open-hole (w) can be calculated using the underlying values of both position lines. Based on the minimum distance the Standoff (ST) can be calculated.

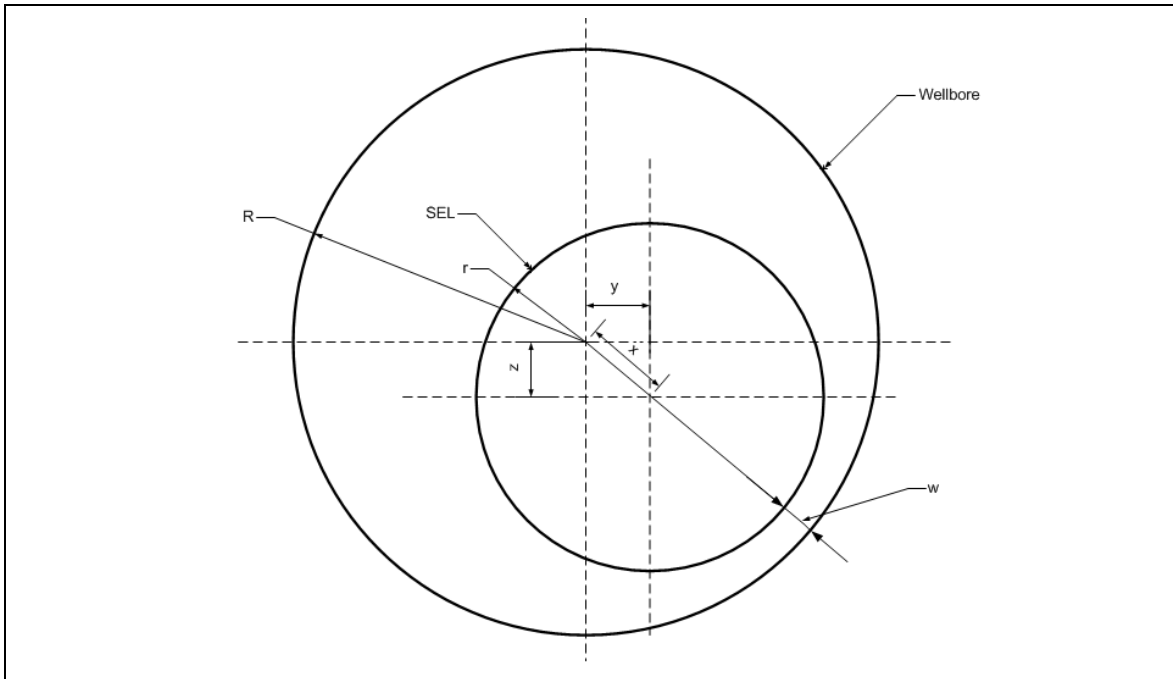

**Figure 51:** Schematic sketch of string position plus geometrical considerations to evaluate the standoff for one node – P. Fischer

|                                    |   |
|------------------------------------|---|
| $w = R - r - \sqrt{(y)^2 + (z)^2}$ | R..... Wellbore radius<br>r..... Pipe outer radius<br>y..... Right side position<br>z..... High side position |
|------------------------------------|---|

|                              |  |
|------------------------------|--|
| $ST = \frac{w}{R - r} * 100$ | R..... Wellbore radius<br>r..... Pipe outer radius<br>ST..... Standoff<br>w..... Distance from wellbore-wall |
|------------------------------|--|

**Equation 23-24:** Sketch of string position with the related geometrical considerations to evaluate the Standoff for one node

As already mentioned in case of centralizer application the software assumes an initial position of the string lying along the wellbore wall. The differences in calculation approaches can easily be seen in the standoff results for high inclinations, where centralized strings with high spacings show lower average standoff values as the un-centralized string. This is hardly possible in reality and implements that the first model in which the base position is deduced from the “soft string model” produces slightly underestimated standoff values. So the non centralized string standoff values, which are based on the stiff string calculation approach, can be assumed to be more accurate as the centralized string standoff results

## Software Limitations

(1) Tortuosity is as a separate option as part of the data input sheets in the Centralizer Placement mode under the Wellpath Editor wizard, where the tortuosity parameters and of approach can be defined. But in the standoff results the tortuosity implemented via the designated option doesn't show any influence. It can be easily shown that the implementation of a tortuosity profile has an influence on the standoff indicating that the software ignores a requested value. To simulate the tortuosity influence a predefined inclination and azimuth variation had to be implemented to the well path profile. This eliminates the option to use an irregular profile which is created with a random number-generator integrated in the software.

(2) The major limiting factor was the fact that the software assumes, for the designated option for standoff calculations, that the initial position of each string within the wellbore is based on the soft-string-model. So the stiffness of the pipe is not taken under consideration as long as no centralizer is implemented. The string is assumed to follow each well-path continuously contacting the wellbore wall. Due to multiple reasons such as irregularities of the well-path profile (tortuosity) or wellbore geometry the pipe can be easily deflected at several points across the open-hole section, which leads in combination with the stiffness of the string to deflections off the wellbore wall over larger distances. To consider these circumstances a stiff string model would be required, which would allow the direct standoff calculation for non centralized strings and would provide more accurate results for the simulation of centralized strings.

(3) The material properties of the pipe changes due to the cold working of steel (expansion process) as described in chapter one. To implement the post expansion pipe properties to define a new steel grade a wide range of material properties would be required. For the Standoff calculation especially the implementation of an adjusted Young's Modulus would be necessary. Bending of the pipe in deviated wells charges the pipe in multiple directions. Furthermore the material properties of cold worked steel are anisotropic so the implementation of one accurate value representing the bending behavior, as demanded by the software, under changing load directions is impossible.

(3) For the OptiCem standoff calculation oversized connections are not taken under consideration. As the diameter is minor compared to the deflection caused by the centralizers this simplification has only a low potential to adulterate the simulation results.



## **Results and Conclusion**

### **Enventure SEL System**

The Enventure systems operational sequence, as already explained in detail in the previous chapters, envision the entire preconditioning and cement placement preliminary to the pipe expansion process. The primary contribution of centralization for cementation optimization was identified (see previous chapter) to be an improvement of annular flow conditions, which subsequently enhances the wellbore preparation (conditioning) and cement placement quality.

As a result the centralization of the pre-expanded pipe is of special interest. The simulation shows that with a 9 5/8 [in] Enventure SEL under pre expanded conditions it is not possible to reach a degree of centralization as recommended by API for good cementation practice, for the entire range of implemented parameters. With the installation of centralizers and ultra low spacing parameters (15 [ft]; 18 [ft]) a maximum standoff value of 44 [%] can be achieved under optimum hole conditions (perfect gauge/nominal open-hole diameter).

However, for these low spacings the influence of the inclination is minor over the entire range of hole-quality. Only after the increase in spacing the higher fraction of weighting force caused by the inclination gain intensifies the pipe bending sufficiently to decrease the standoff. Without the implementation of centralizers the string reaches, for inclined well conditions, a relatively constant standoff of about 8 [%], for a vertical well with tortuosity, about 28 [%].

It is pretty obvious that with a max standoff value of 44 [%] under optimum conditions, which is 23 [%] below the min value recommended by the API, an accurate cementation placement can hardly be achieved.

The final string position in the wellbore is given by the post-expansion standoff. The cement is already placed in the annulus and only mobilized by the decrease in annular clearance due to the pipe diameter increase. This definitely contributes to the cement annular allocation as explained in the previous chapter.

Therefore the post-expansion standoff plays an important role but not in a common matter of sense. The API standoff recommendation of 67 [%] is based on conventional system designs where the entire cementation process occurs while maintaining almost one degree of centralization. So for the post expansion results the API criterion, as a benchmark, has to be taken with caution. Nevertheless, the centralized Enventure SEL reaches, for narrow spacings of 15 [ft] and 18 [ft], with excellent hole conditions and over the entire range of inclinations, a value of 69 [%].

With the decrease in annular clearance due to the increase in pipe diameter (expansion) as well as a constant centralizer deflection and open-hole diameter the degree of centralization is increased. But with increase in spacing and effective hole-diameter away from the minimum respectively optimum value the standoff drops below API recommendations. Once again even in the post expanded state the minimum centralization requirements to achieve good quality cementation cannot be fulfilled. It has to be pointed out that compared to conventional systems the centralization capabilities of the Enventure SEL system are poor.

Even under optimum conditions it is not possible to reach an accurate standoff level. But we do have a significant improvement to the non centralized SEL application. For optimum conditions the standoff is increased by 35 [%] for the pre- and even 55 [%] for the post-expanded string compared to an un-centralized pipe. This fact would already justify the application of centralizers, as at least a cement quality improvement can be expected.

Especially, due to the low annular clearance and the consequential restriction in centralizer thickness as well as the low pre expansion pipe diameter in relation to the oversized hole, which is required to accommodate the post-expanded pipe, an accurate centralization in terms of cementation can hardly be achieved.

Even with an optimization of hole conditions and a more accurate coordination of design parameters as centralizer spacing and hole parameters such as tortuosity or hole geometry,

only an improvement which ranges below the API recommendation is achievable as the simulation of the optimum conditions couldn't break 67 [%].

For more substantial improvements a general reassessment of the design approach has to be considered. Either more advanced centralizer designs have to be investigated, such as down-hole activated designs, or the entire operational sequence of the SEL system has to be reconsidered.

It seems obvious that due to the given geometrical ratio between pipe, centralizer, and open-hole it is way harder to achieve a higher standoff for the pre- as for the post-expanded pipe. So in terms of cementation optimization the service provider should consider a modification of the system design to change the operational sequence.

## **Baker SEL System**

As already mentioned the Baker system differs in terms of cementation from the Enventure system dominately in the operational sequence. The entire cementation process is performed post expansion. No cementation relevant operation is performed pre-expansion. For this reason only the post expanded pipe was examined in detail.

Furthermore, the available centralizer technology only provides centralization capabilities in the post expanded state. The simulation of the centralized string over the entire range of hole-qualities and centralizer application design parameters show that the technology is able to fulfill the minimum requirements for most of the simulated circumstances. As the entire cementation process is comparable to conventional application the API recommendation is an adoptable benchmark.

For a slightly inclined well (15 [°]) the standoff value drops below the benchmark at a 60 [ft] spacing utilized for an extremely poor hole quality. For minimum spacing and maximum hole quality a standoff value of almost 100 [%] could be achieved. Compared to the non centralized string this is an increase of almost 90 [%].

The system shows a higher sensitivity to inclination increases although the bending resistance of the string is comparable to the Enventure product. This can be related to the fact that the bow type centralizer is compressible and the standoff at the centralizer points reacts on load increases (tangential force). Nevertheless, even for a horizontal tangential section the simulation shows accurate values for a wide range of matrix parameters.

The standoff value drops below the 67 [%] recommendation for the first time at a 45 [ft] centralizer spacing applied in medium hole quality. In case of a vertical well profile the centralized string shows a standoff above the benchmark within the entire simulated conditions.

Based on the simulation results the system can, with the actual state of development, already be applied over a wide range of parameters. With slight technical improvements, such as an increase of the substandard centralizer restoring force, as well as a better planning of design parameters, such as the alignment of spacing and tortuosity profile, the operational area can even be increased. Furthermore, the system allows an economic optimization, as in case of the amount of centralizers installed, enough contingency is available.

It can be pointed out that regarding standoff the Baker SEL system shows a way better performance as the Enventure system. This can be directly related to the different design approaches of pre and post-expansion cement placement as well as the utilization of the pipe expansion process for the operation of a down-hole activated centralizer.

# Standoff Simulation – Real World Data Well A

## Well A – Introduction

Well A was drilled and completed to final depth in the end of the first quarter 2006 by RWE Dea. The expected productivity could never be reached due to unexpected geological structures as a calcite formation caused a significant disturbance of the facies, as studies by order of RWE-Dea suggest. Due to the low production rate combined with the high water cut of 50 [%], the submersible centrifugal pump was operated in the down-trust area, which reduces the life expectancy of the production device dramatically.

A change of the pump to an alternative device was considered not to be economic, so the decision was made to plug the well in the 9 5/8 [in] or 13 3/8 [in] casing section with a cement bridge and kick off to reach the same target formation (Dogger beta) in another area.

The plan for the sidetrack Well A includes a long (1070 [ft]) almost 90 [°] horizontal section to reach the section of Dogger Beta with a lower water encroachment defined over three target points.

The complex pressure profile of the geological area made the planning and execution of the sidetrack difficult to perform. Especially the pressure depleted Dogger delta reservoir directly below the kick off point and the Dogger beta which is highly charged due to several injection wells along the entrance area of the wellbore A/a into the formation, made the casing design program a challenge. Initially three different planning scenarios have been taken under consideration.

Exit the 9 5/8 [in] casing of Well A at about 2250 [m] and drill an 830 [m] section down to 3180 [m] to the top of the high pressure Dogger beta. The section would contain 460 meters of shale formation, cover the depleted Dogger Delta and would be cased and cemented with a 7 inch liner. The final 1070 [m] horizontal section should be cased with a 5 inch liner.

The second plan is based on a kick off in the 13 3/8 [in] casing of Well A. The first section should drill through the depleted Dogger Delta and end at the top of Dogger Gamma. The section should be about 1080 [m] in length and cased with a 9 5/8 [in] casing. Over the 670 [m] 7 [in] liner section down to top of Dogger Beta the inclination should be increased to an almost horizontal well pass. The final 1070 [m] should again be cased with a 5 [in] liner.

The third plan envisaged a kick off at 2250 [m] out of the 9 5/8 [in] casing of the Wellbore A/a. The first section should cover the whole Dogger delta shale (160 [m]) and should have a length of 440 [m] down to the top of Dogger gamma. The section should be drilled with an 8 ½ [in] bit and enlarged to 9 7/8 [in] with an under-reamer.

Finally the section will be cased with a 7 5/8 [in] SEL expanded to 8,427 [in]. The second section should be drilled (6 1/8 [in]) and extended (8 ½ [in]) down to 3180 [m] to the top of Dogger Beta increasing the inclination to almost horizontal and cased with a 7 [in] liner from 2130 -3180 [m] covering the hole expandable liner section. The hole will finally end up in the same horizontal sections mentioned in the scenarios above.

The application of the SET system to handle the pressure situation (depleted Dogger Delta, high charged top of Dogger Beta) showed after evaluation the lowest potential risk going along with moderate costs. So RWE-Dea made the decision to install the first expandable liner in company history. As the Enventure SEL product was the marked leading technology and fitted best the technical prerequisites it gains the acceptance of the tender.

But nevertheless one of the operator company's major concerns coming along with the new technology was the cementation job quality to seal the Dogger Delta formation. Due to the fact that the cement job for SEL in general and especially for the applied product (see previous chapter) differs significantly from the good practice of liner cementation it was doubted whether the cementation would reach an acceptable quality. Especially the centralization of the string in the extended and highly deviated hole-section, in which the SEL string was supposed to be installed, worried the engineers.

At the time of this first SEL installation the service provider couldn't provide any in-house centralizer or recommend an external one. So for this installation no centralization could be achieved. In the end the risk was taken and regarding the cementation the SEL was successfully installed. But as the SEL technology was identified as a adequate tool solve very common operational problems and the intention was born to implement this technology in further drilling projects, the decision was made that the system disadvantage regarding centralization has to be investigated. This consideration is the background for the simulation and investigations performed in this Thesis.

## **Simulation**

For the Wellbore A/a the Enventure product was the only applicable SEL solution, due to technical considerations. As the wellbore is sidetracked out of an existing well (9 5/8 [in]; Well A), an installation of special oversized shoe as bottom joint of the base casing is not possible. As this is a requirement for the Baker SEL technology the system is not suitable. But nevertheless as the intention is to investigate the standoff for both SEL technologies with the related centralization techniques based on real well data, it is assumed that the installation of both technologies would be possible.

So with the simulation the standoff values of different SEL installation options in well A19a located in the North-Sea is evaluated. Both pre-described SEL technologies are investigated with and without centralizers applied.

The calculation approach and the utilized software equal those described in the previous chapter. This simulation is a complement to the initial SEL standoff simulation and is aimed to investigate the standoff for a less generalized and simplified application. The simulation base case is founded on the available wellbore parameters.

The SEL string installation parameters are based on the planed design. The fact that the string in reality couldn't be run to the desired setting depth was ignored as it wouldn't have an influence on the qualitative outcome of the simulation.

## **Base case**

Figure 52-53 show the geometrical parameters required for the simulation. As it can be seen in the schematics the open-hole diameter requirements for the Baker system are slightly higher as for the Enventure product. In reality the section was completed with the Enventure SEL system. So all available open-hole information, such as well path (tortuosity) and hole-quality, are related to a 9 5/8 [in] open hole-diameter.

For the simulation it was assumed that these parameters can be directly assigned to the 10 1/4 [in] open hole. The open hole-quality of the under-reamed section was examined by the responsible engineer. Geometrical irregularities of the drilled distance cause an total volume increase of 18 [%] of the entire open hole section. This value is used to evaluate an equivalent diameter of 11,134 [in] for the nominal 10 1/4 [in] hole and 10,726 [in] for the 9 5/8 [in] hole.

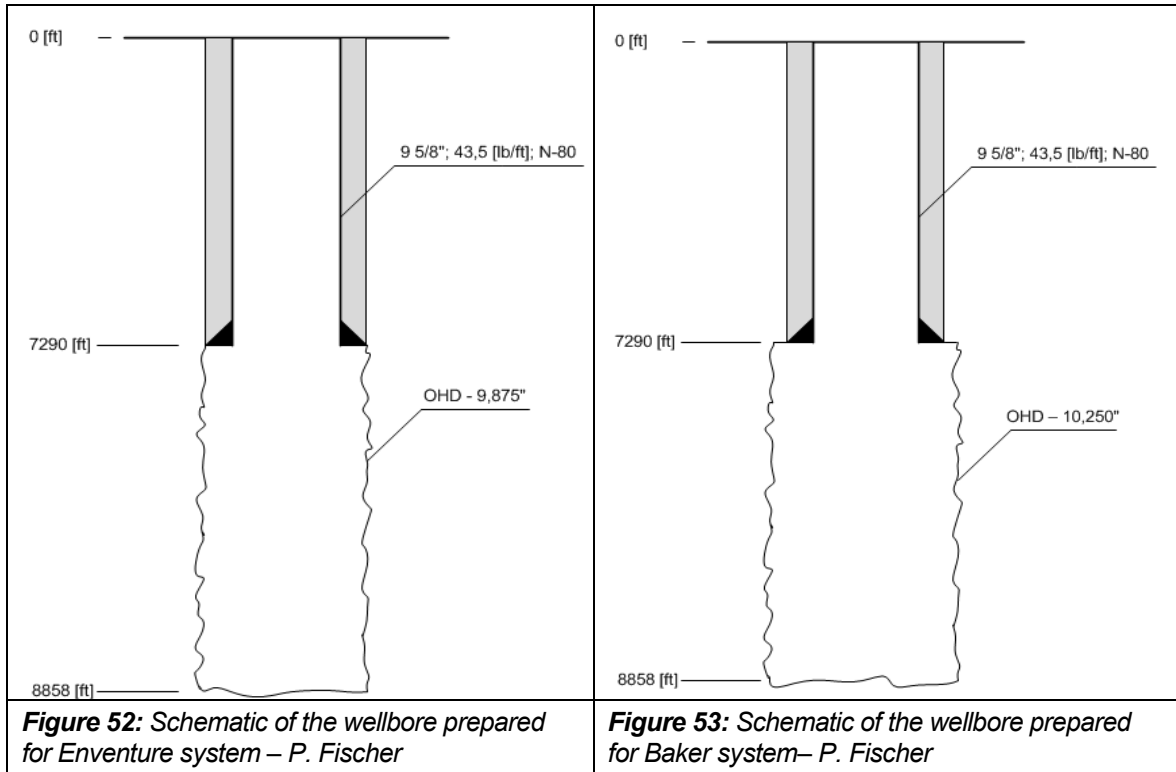

The SEL is set in a build section from 16 [°] to 47 [°] inclination and a change in azimuth from 133 [°] to 163 [°] (Figure 54-55). Dog-Leg Severity and absolute tortuosity are given in Figure 56. The dogleg severity ranges between 1[°] to 3,5 [°] with strong variations across the investigated section. The highest values can be found directly below the base casing shoe down to 7600 [ft], between 7900 and 8200 [ft] and from 8700 [ft] to the bottom of the hole. The absolute tortuosity is relatively constant over the entire hole-section.

| Open Hole Survey |                 |             |
|------------------|-----------------|-------------|
| MD [ft]          | Inclination [°] | Azimuth [°] |
| 7275,3           | 15,85           | 133,35      |
| 7411             | 19,25           | 140,99      |
| 7573,5           | 23,41           | 147,82      |
| 7666,4           | 25,37           | 149,1       |
| 7761,5           | 27              | 149,49      |
| 7855,1           | 29,28           | 149,67      |
| 7948,9           | 32,07           | 150,27      |
| 8043,9           | 34,35           | 152,52      |
| 8136,8           | 36,84           | 155,87      |
| 8230,3           | 37,92           | 157,96      |
| 8323,8           | 38,02           | 156,66      |
| 8417,7           | 39,34           | 158,55      |
| 8512,3           | 40,87           | 161,02      |
| 8605,1           | 41,87           | 161,87      |
| 8699,1           | 44,24           | 161,73      |
| 8792,90          | 46,74           | 163,45      |

**Table 13:** Survey of solid expandable liner open-hole target section

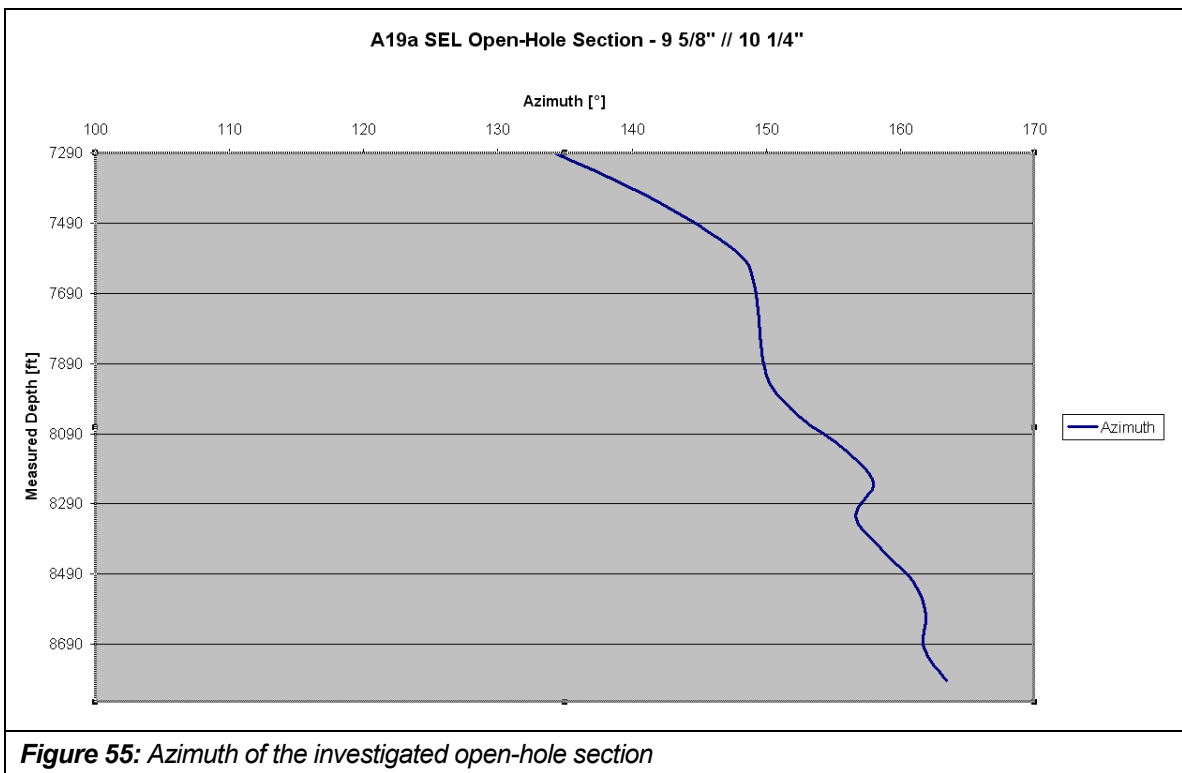
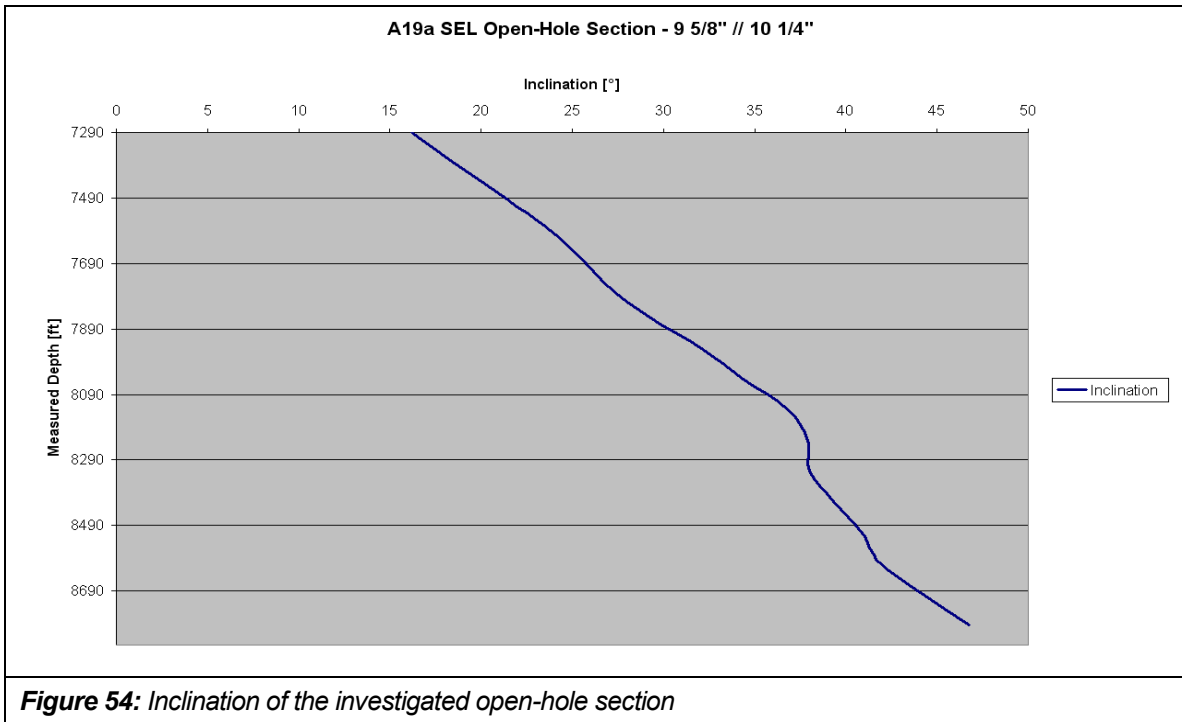

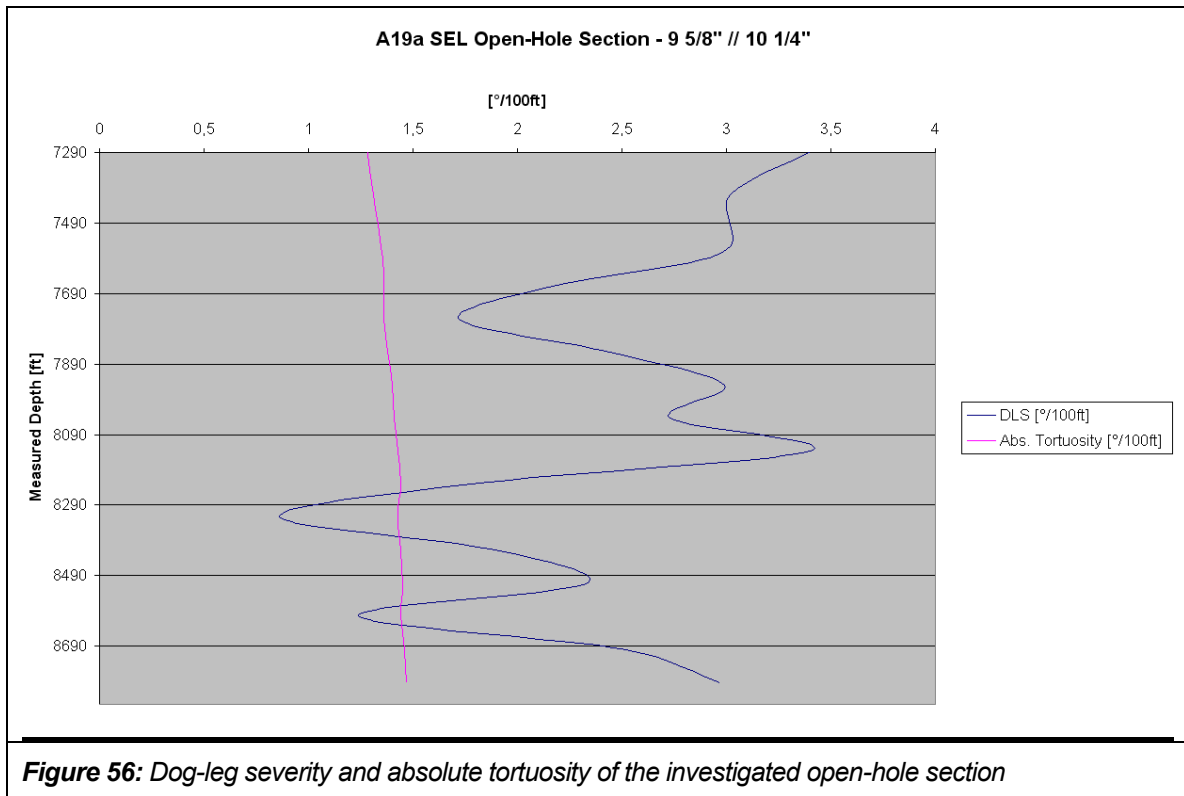

## SEL-String

### Enventure SEL System

The system including cementation procedure and centralization options was already explained in the previous chapters. For the investigated well the operator decided to utilize this system. This fact allows a direct comparison of the achieved results with the real well situation after the job was performed. As for Wellbore A/a an extension of the 9 5/8 [in] casing was installed, string and centralizer design are almost equal to those used in the matrix simulation (Table 14-15). The standoff was again simulated pre and post expansion with and without centralizers applied. In case of the centralized string a soft string model used to implement the initial position and standoff is exclusively created by the centralizers installed. The oversized couplings are not taken under consideration. For the non-centralized string a stiff string model was utilized, allowing the oversized couplings to be considered.

| <b>Wellbore A/a Enventure SEL String</b> |               |     |                             |               |     |
|--|---------------|-----|-----------------------------|---------------|-----|
| <i>SET - Pre-Expansion</i>               |               |     | <i>SET - Post-Expansion</i> |               |     |
| OD - body/coupling                       | 7,625 / 7,825 | in  | OD - body/coupling          | 8,427 / 8,618 | in  |
| ID                                       | 6,875         | in  | ID                          | 7,71          | in  |
| Weight                                   | 29,7          | ppf | Weight                      | 30,88         | ppf |
| Grade                                    | EX-80         | -   | Grade                       | EX-80         | -   |
| Length                                   | 2036,8        | ft  | Length                      | 1724,7        | ft  |
| Launcher -OD                             | 8,379         | in  | Launcher - OD               | 8,379         | in  |
| Launcher/ Shoe - Length                  | 15,68         | ft  | Launcher/ Shoe - Length     | 15,68         | ft  |

**Table 14:** SEL string specifications for wellbore A/a – Enventure system

| <b>Centralizer</b>   |       |    |                       |       |    |
|----------------------|-------|----|-----------------------|-------|----|
| <i>Pre Expansion</i> |       |    | <i>Post Expansion</i> |       |    |
| Type                 | Rigid | -  | Type                  | Rigid | -  |
| Ref. Casing Diameter | 7,625 | in | Ref. Casing Diameter  | 8,427 | in |
| Hole Diameter        | 9,875 | in | Hole Diameter         | 9,875 | in |
| Nominal Diameter     | 8,625 | in | Nominal Diameter      | 9,427 | in |
| Length               | 15    | in | Length                | 15    | in |
| Number of Bows       | 3     | -  | Number of Bows        | 3     | -  |

**Table 15:** Specifications of SEL centralizers available for the Enventure system

Initially an equal set of spacings as already implemented for the matrix simulation is used for the wellbore A/a Enventure string standoff simulation (15 [ft]; 18 [ft]; 36 [ft]; 45 [ft]; 60 [ft] 72 [ft]). As the investigated open-hole section is non-homogeneous in inclination and azimuth, additionally an individual spacing program was designed to optimize the centralizer application. As fluid densities within and outside the string have an influence on standoff due to the buoyancy effect, the cement program as planned for the SEL application was implemented (Figure 57-58).



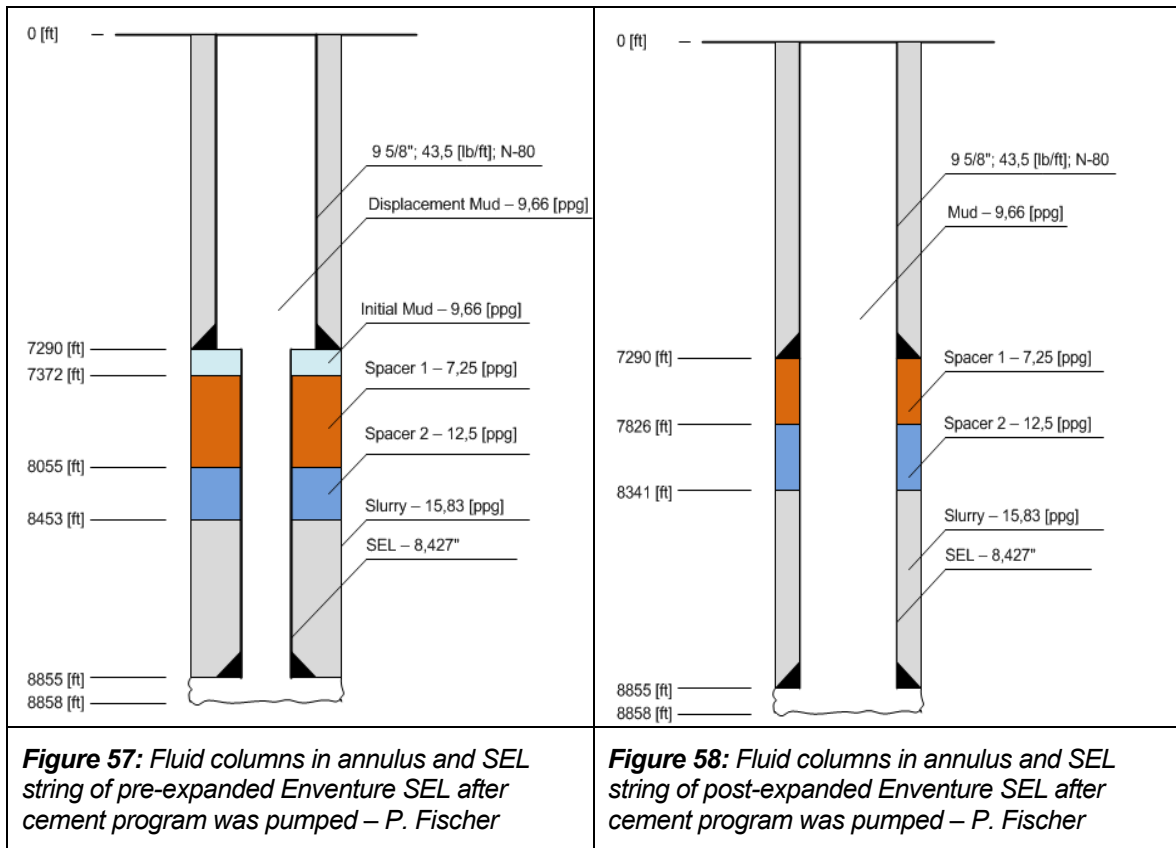

### Baker SEL System

The system major specifications as well as available centralizer designs have already been explained in detail in the previous chapters. The wellbore A/a was completed with the Enventure system. So a comparison of the simulation output with the reality is not possible. Furthermore well-path irregularities and wellbore quality are assumed from the 9 5/8 [in] hole drilled for the enventure system. As the open-hole diameter requirements for the baker SEL string are slightly higher (10 ¼ [in]) this has to be outlined as a necessary assumption. Once again the standoff was simulated pre and post expansion with and without centralizers applied. In case of the centralized string the oversized couplings are again not taken under consideration. Only for the non-centralized string the software is able to consider the couplings.

| <b>Baker SEL String</b>    |          |     |                             |               |     |
|----------------------------|----------|-----|-----------------------------|---------------|-----|
| <i>SET - Pre-Expansion</i> |          |     | <i>SET - Post-Expansion</i> |               |     |
| OD - body/coupling         | 8 / 8,25 | in  | OD - body/coupling          | 9,287 / 9,335 | in  |
| ID                         | 7,31     | in  | ID                          | 8,675         | in  |
| Weight                     | 28,2     | ppf | Weight                      | 29,33         | ppf |
| Grade                      | L-80     | -   | Grade                       | L-80          | -   |
| Length                     | 1594.7   | ft  | Length                      | 1532,1        | ft  |

**Table 16: Baker SEL string specifications**

| Centralizer          |        |     |
|----------------------|--------|-----|
| Post Expansion       |        |     |
| Type                 | Bow    | -   |
| Ref. Casing Diameter | 9,287  | in  |
| Hole Diameter        | 10,25  | in  |
| Nominal Diameter     | 11,375 | in  |
| Minimum Diameter     | 9,287  | in  |
| Length               | 27,88  | in  |
| Number of Bows       | 7      | -   |
| Restoring Force      | 2150   | lbf |

**Table 17:** Specifications of SEL centralizers recommended by Baker

Initially, an equal set of spacings as already implemented for the matrix simulation is used for the standoff simulation (15 [ft]; 18 [ft]; 36 [ft]; 45 [ft]; 60 [ft] 72 [ft]) of the post expanded string. As well as for the Enventure application an individual spacing program was designed to optimize the centralizer installation. The same cement program, as implemented for the Enventure SEL application, was utilized to contribute for the buoyancy effect (Figure 59). As the cement is pumped post expansion for the baker SEL system the fluid in the wellbore pre expansion is homogeneous (initial mud) with a density of 9,66 [ppg].

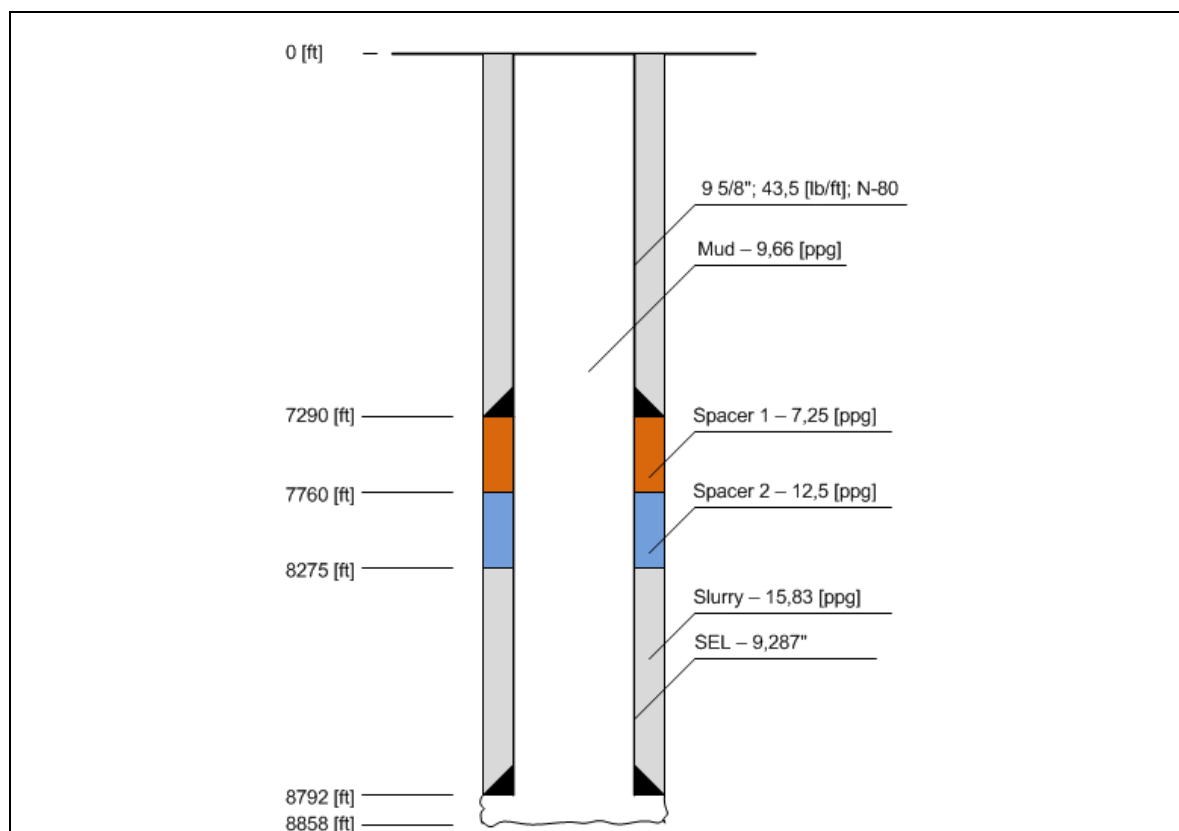

**Figure 59:** Fluid columns in annulus and SEL string of post-expanded Baker SEL after cement program was pumped – P. Fischer

## **Results and conclusion**

### **Enventure System**

The enventure system was the actually applied system for this well. The string was run without centralizers utilized. The simulated standoff for the unique distance spacing set (15 [ft]; 18 [ft]; 36 [ft]; 45 [ft]; 60 [ft] 72 [ft]) as well as the non centralized string in the pre and post expanded state are visualized in Figure 60-61. As a quantitative indication the API recommended Standoff value of 67 [%] is outlined as well. As it can be seen (Figure 60-61) the standoff values for the pre as well as for the post expanded state are far below the recommendation. Even with centralizers applied with ultra low spacing of 15 [ft] the standoff only reaches values of 32 [%] for the pre and 44 [%] for the post expanded state. At least implementation of an ultra low spacing allows compensating for the irregularities in well profile and results in a relatively homogeneous standoff over the entire SEL section. With the increase in spacing the standoff is reduced and starts to become irregular over the open-hole section. A reduced standoff can be seen in between 8450 [ft] -8200 [ft], 8000 [ft] – 7700 [ft] and from 7300 [ft] to the base casing shoe for the pre-expanded SEL. For the post expanded string the standoff reduced section range from 8300 – 8000 [ft], from 7800 – 7600 [ft] and from 7400 [ft] to the base casing shoe. These sections of reduced standoff are only slightly shifted between pre and post expansion state and match very accurately the sections of increased dogleg severity shown in Figure 56. For the comparison of the centralized and the non centralized string standoff results it has to be considered that different calculation approaches have to be utilized. Due to the considered stiffness of the casing and the oversized couplings the standoff output over the investigated section is very homogeneous and even slightly higher as the ultra wide spacing applications. It can be assumed that the stiff string model matches the real behaviour of the pipe more accurately.

The installation of centralizers show a significant impact on standoff, especially for narrow spacing installations, but nevertheless the API recommendations cannot be reached.

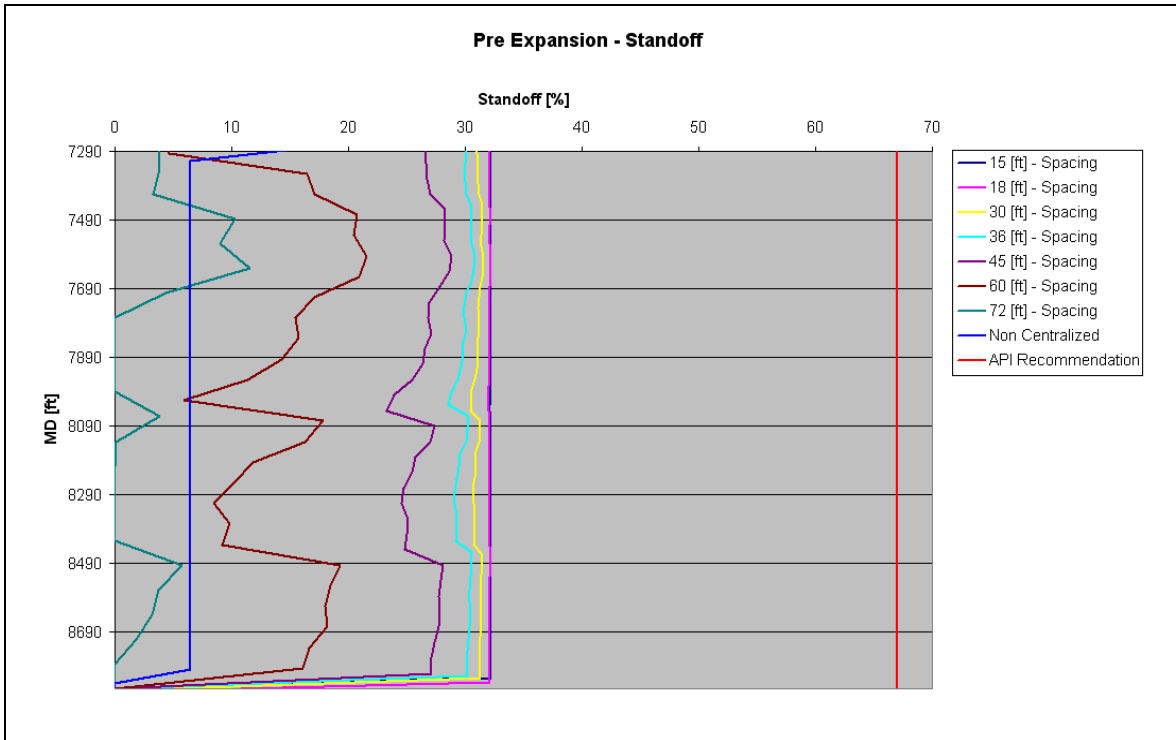

**Figure 60:** Pre expansion standoff values for the Enventure SEL string with centralizers installed (multiple spacings) and without centralizers installed across the desired open-hole section between 7290 feet and 8858 feet measured depth in wellbore A/a

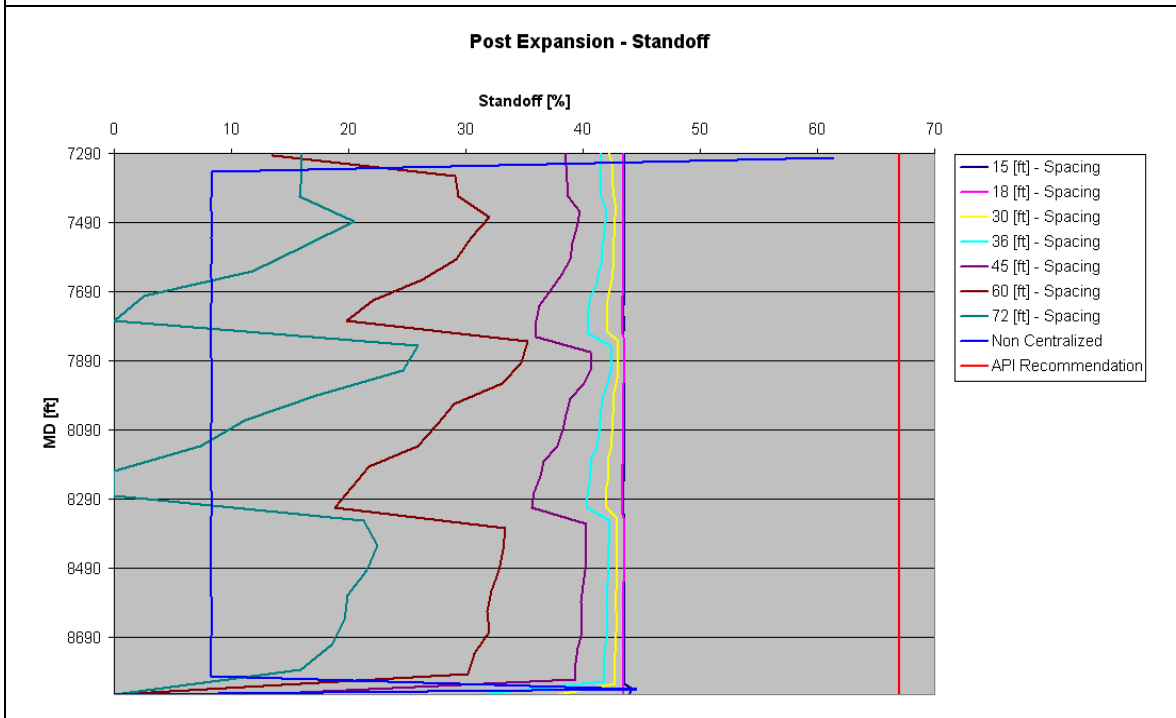

**Figure 61:** Post expansion standoff values for the Enventure SEL string with centralizers installed (multiple spacings) and without centralizers installed across the desired open-hole section between 7290 feet and 8858 feet measured depth in wellbore A/a

It can be observed that especially the impact of narrow spacing on standoff profile is low. On the other hand the standoff variation along the open-hole section is high.

Although the optimum standoff is reached with a narrow spacing between 15-18 [ft], due to drag as well as hydraulic considerations and optimization of the spacing to reduce the number of centralizers while maintaining a high as possible degree of centralization might be necessary.

To optimize the spacing the value at which the influence on standoff becomes more severe was identified. With a spacing of 45 [ft] the standoff variation becomes more sensitive with increasing distance between the centralizers. Therefore the 45 feet value was chosen to be optimized.

As it is not possible to orient the standoff profile optimization according to the API recommendation, this value can never be reached. So for the pre or post expansion standoff profile two imaginary lines have been drawn along which, based on the geometry, it seems to be adequate to optimize the two 45 [ft] profiles.

For the pre expansion a value of 27,5 [%] was chosen for the post expanded string a value of 39 [%] was selected. As soon as the 45 [ft] spacing standoff value falls below the selected boundary line, the spacing has to be increased so that the standoff remains above the boundary value.

As a result several depth ranges for the pre as well as for the post expanded string have been identified along which the spacing has to be reduced. As only one spacing program can be applied and the magnitude of the standoff variation of the pre and post expansion string seems to be strongly related but shifted along the depth, the depth intervals which require a spacing reduction have been related to each other and simply averaged (Table 18). Based on these evaluated depth ranges a spacing was selected for each range geared to 45 [ft] or lower to achieve maximum standoff with a minimum number of centralizers installed (Table 19).

| <b>Investigated depth Ranges - for Spacing Correction [ft]</b> |                       |                |
|--|-----------------------|----------------|
| <i>Pre Expansion</i>   | <i>Post Expansion</i> | <i>Average</i> |
| 7290 - 7410  | 7290 - 7410           | 7290 - 7410    |
| 7410 - 7890  | 7410 - 7590           | 7410 - 7740    |
| 7890 - 8050  | 7590 - 7810           | 7740 - 7930    |
| 8050 - 8170  | 7810 - 7990           | 7930 - 8080    |
| 8170 - 8450  | 7990 - 8330           | 8080 - 8390    |
| 8450 - 8810  | 8330 - 8810           | 8390 - 8810    |
| 8810 - 8855  | 8810 - 8855           | 8810 - 8855    |

**Table 18:** Depth range evaluation for standoff optimization

| <b>Spacing Optimization</b>      |                                 |
|----------------------------------|---------------------------------|
| <i>Measured Depth Range [ft]</i> | <i>Centralizer Spacing [ft]</i> |
| 7290 - 7410                      | 36                              |
| 7410 - 7740                      | 45                              |
| 7740 - 7930                      | 36                              |
| 7930 - 8080                      | 45                              |
| 8080 - 8390                      | 36                              |
| 8390 - 8810                      | 45                              |
| 8810 - 8855                      | 15                              |

**Table 19:** Evaluated depth range with selected spacing

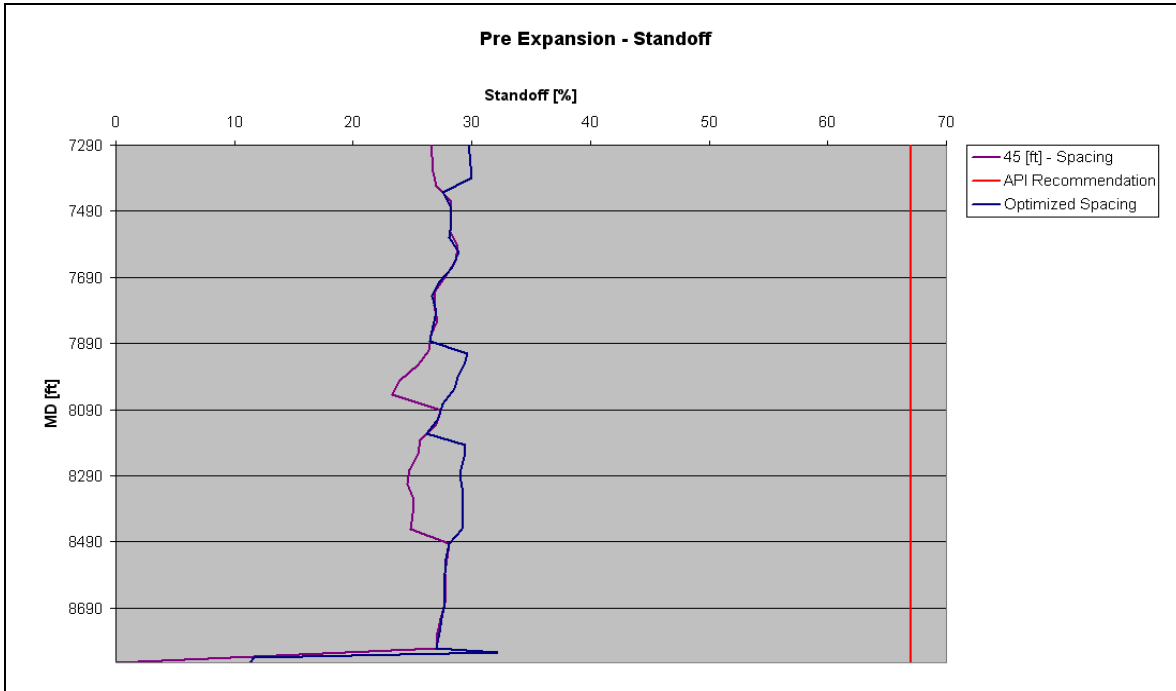

**Figure 62:** Pre expansion standoff values for the Enventure SEL string across the desired open-hole section between 7290 feet and 8858 feet measured depth in wellbore A/a; comparison of optimized profile with a homogeneous spacing of 45 [ft]

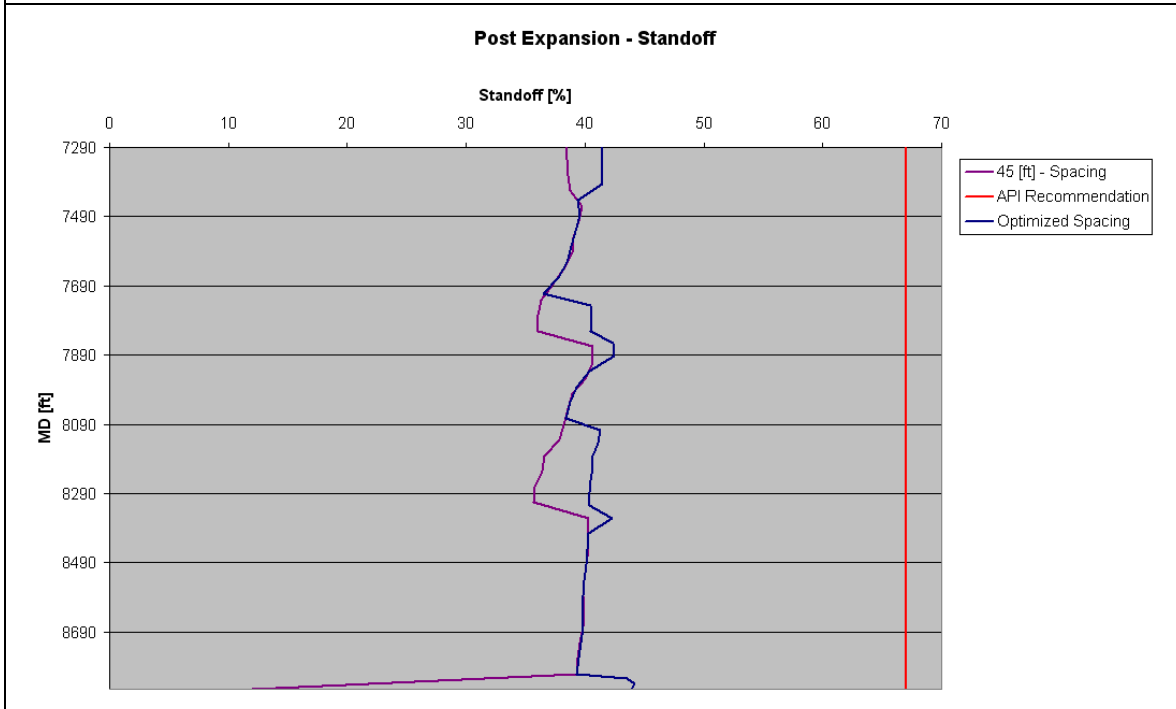

**Figure 63:** Post expansion standoff values for the Enventure SEL string across the desired open-hole section between 7290 feet and 8858 feet measured depth in wellbore A/a; comparison of optimized profile with a homogeneous spacing of 45 [ft]

| Optimization Results              |    |           |    |
|-----------------------------------|----|-----------|----|
| Spacing [ft]                      | 45 | Optimized | 36 |
| Aver. Standoff pre-expansion [%]  | 26 | 28        | 29 |
| Aver. Standoff post-expansion [%] | 38 | 40        | 41 |
| Utilized Centralizer [/]          | 35 | 40        | 44 |

**Table 20:** optimization results

Although the impact of the optimization is not significant (Figure 62-63; Table 20), at least the reduction of 4 centralizers could be achieved causing a standoff decrease less than expected based on the homogeneous centralizer spacing. Furthermore, the standoff along the bottom section could be heavily increased by simple installing two more centralizers. This improves especially the cement job quality at the casing shoe, which is, as outlined in the previous chapters, of special importance for the overall job quality.

## Baker System

The Baker system was not applied for Wellbore A/a as a 9 5/8 [in] casing extension. For the standoff simulation the same procedure was applied as for the Enventure string. A range of unique distance spacings for centralizer installations was simulated as well as the non centralized string.

As the Baker centralizers do not contribute to the standoff in the pre expanded pipe state, as they are activated by the expansion process, the profile for the non centralized string matches the centralized (Figure 64-65). In the post expanded state, in which the cement is pumped in place, the standoff simulation shows that it is possible to exceed the API recommendation over the entire string length with narrow spaced centralizers. With the minimum unique distance spacing of 15 [ft] for the bow type centralizer it is possible to reach an arithmetic average standoff of 77,9 [%].

The entire standoff profile remains above the API boundary of 67 [%] for the 15 [ft]; 16 [ft] and 30 [ft] spacing. The standoff profile of the 36 [ft] spacing falls below the recommended value across the bottom of the joint. This tendency can be observed for all spacings applied to the string. It can be related, to the fact that if the last centralizer is installed far above the end of the last joint (max. distance equals spacing), the bottom of the string bends towards the open-hole wall. With the installation of an additional centralizer as close as possible to the SEL shoe section this effect might be compensated.

Above 45 [ft] of spacing between the centralizers the Standoff falls below 67 [%] over wide sections of the investigated hole. The standoff profile of the non centralized string ranges below 10 [%] in the pre as well as in the post-expanded state. The fact that the post expanded standoff is slightly lower than the pre-expanded although the annular clearance is reduced can be related to the fact, that with the expansion process the coupling deflection capability of the Baker SEL string diminishes.

The standoff profile of all spacings show comparable profile tendency to diminish with an increase in dog leg severity although the effect is not that severe. Especially, in the depth of 8200 [ft] and 7700 [ft] the standoff is significantly reduced and reaches for the max simulated spacing of 72 [ft] a value of 28 and 13 [%]. This observation shows, once again, the strong correlation of standoff and dogleg severity.

With the Baker system the simulation shows that it is possible to reach the API recommendations. Even with a non individualized spacing program an accurate centralization can be reached to perform a high quality cement job. Exclusively based on the centralization

aspect the Baker system provides clear advantages. This proves the result of the initial simulation.

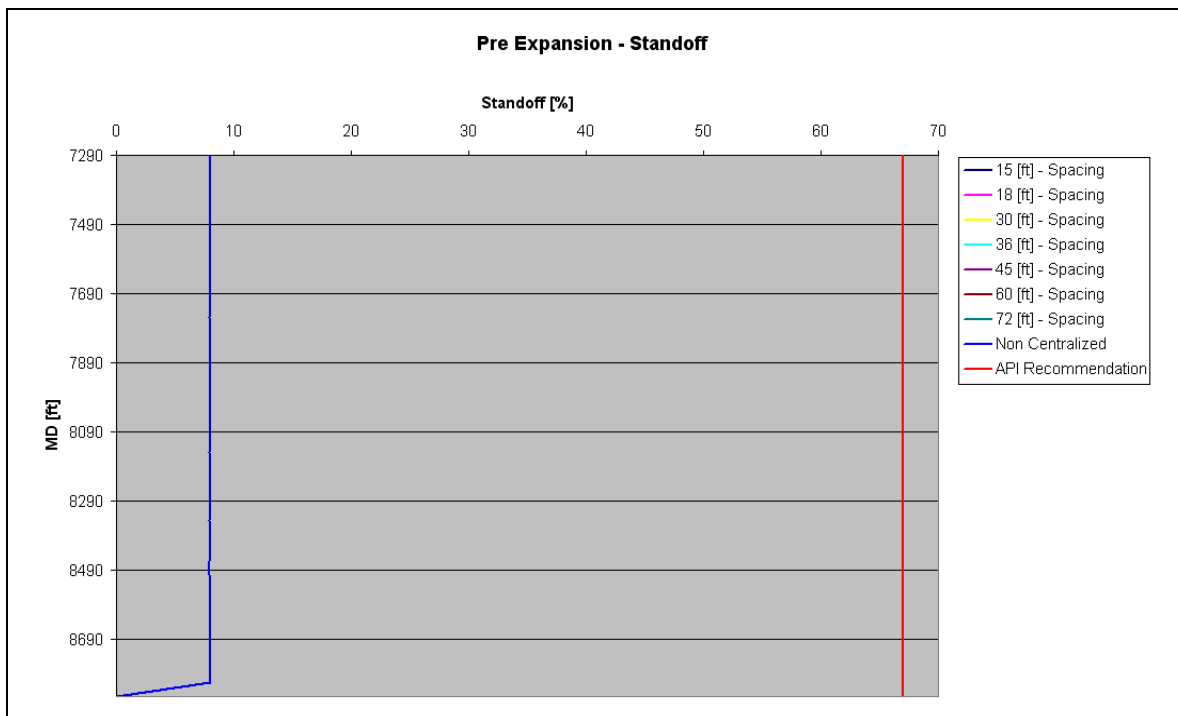

**Figure 64:** Pre expansion standoff values for the Baker SEL string across the desired open-hole section between 7290 feet and 8858 feet measured depth in wellbore A/a

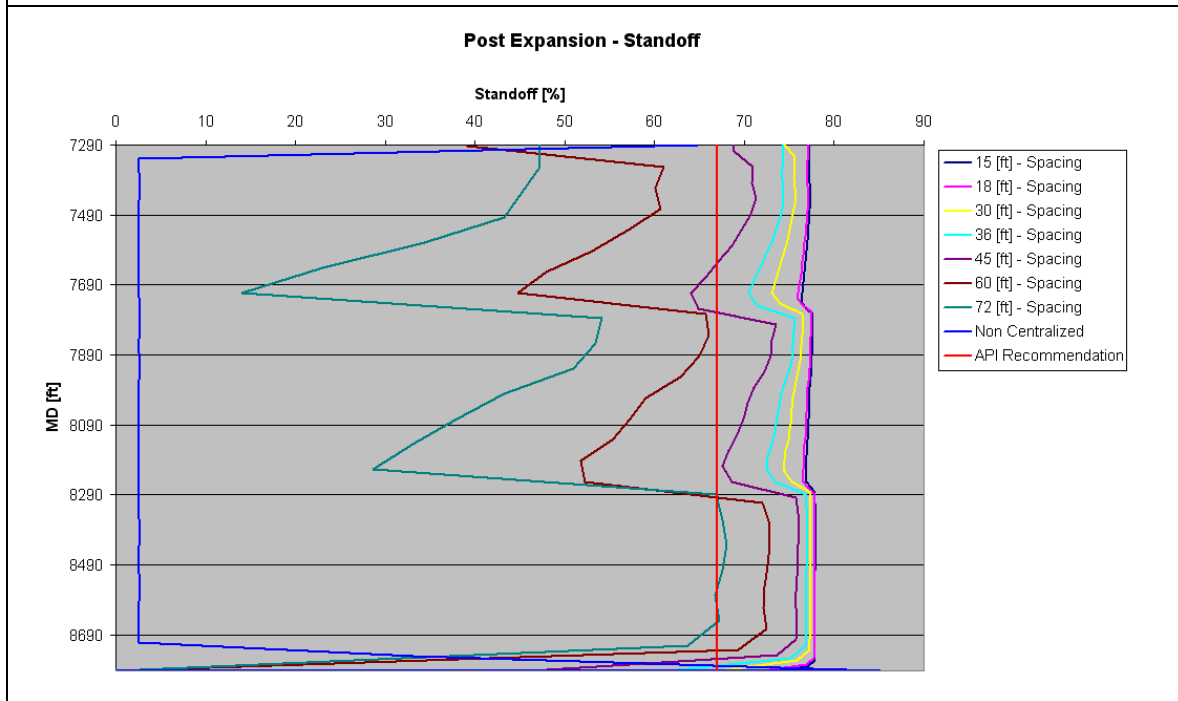

**Figure 65:** Post expansion standoff values for the Baker SEL string with centralizers installed (multiple spacings) and without centralizers installed across the desired open-hole section between 7290 feet and 8858 feet measured depth in wellbore A/a



As it was already mentioned, the highest spacing with a standoff continuously above the API recommendation is 30 [ft] producing an arithmetic average standoff along the investigated open-hole section of 76 [%]. To reach this degree of centralization 51 centralizers have to be installed along the SEL string. To reduce the necessary number of centralizers, while keeping the standoff value above API recommendation, which is used as boundary line, the underlying spacing was varied to optimize the standoff profile. In Table 21 the resulting spacing along the open-hole section is outlined.

The depth intervals are selected with the same procedure as for the Enventure string. The API value represents the boundary value. The 45 [ft] homogeneous spacing is the narrowest which is over wider ranges below 67 [%]. So the intersection points are used as a reference to evaluate the depth ranges across which the spacing has to be reduced to reach the API recommendation. As it can be seen in Figure 66 the optimized standoff profile is continuously above the 67 [%] standoff by utilizing 33 centralizers, which is a reduction of 35 [%].

| Spacing Optimization      |                          |
|---------------------------|--------------------------|
| Measured Depth Range [ft] | Centralizer Spacing [ft] |
| 7290 - 7610               | 45                       |
| 7610 - 7760               | 36                       |
| 7760 - 8250               | 45                       |
| 8250 - 8730               | 60                       |
| 8730 - 8792               | 30                       |

**Table 21:** Optimized Spacing across SEL string

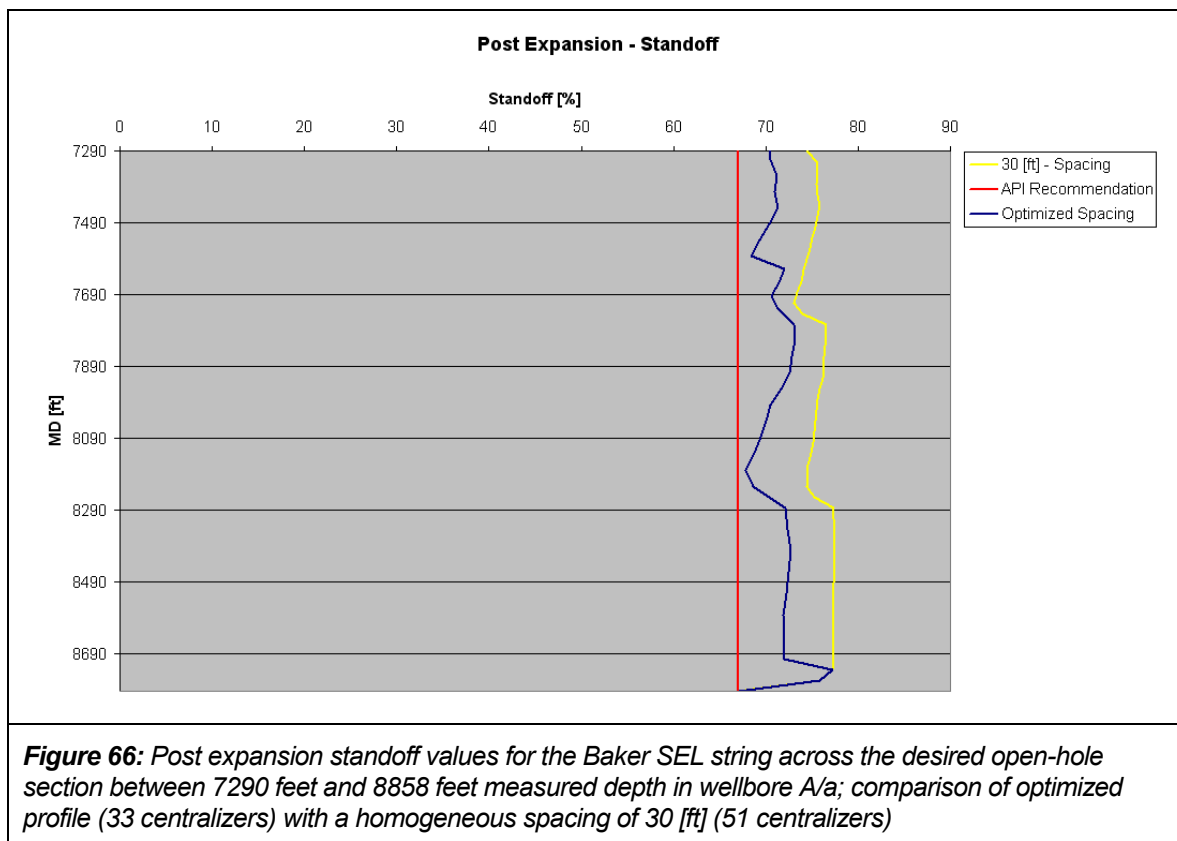

## Well A

Finally it has to be outlined that regarding the degree of centralization the results of the initial simulation have been confirmed. The Baker system, in combination with the in-house expansion activated centralizers, allows high degrees of centralization even exceeding the API recommendation. The Enventure system with the recommended centralizers applied shows a low degree of centralization for the general, as well as for the real world case.

The real cementation of the wellbore A/a did not show evidence of failure although no centralization was applied. But it has to be kept in mind that the importance of cement job quality and the impact of a possible cementation failure were considered to be minor, due to the fact that the entire SEL section was, after drilling the subsequent 8 ½ [in] section, be covered by an 7 [in] liner hung in the 9 5/8 [in] base casing. Furthermore the 7 [in] liner was cemented over the entire length of the SEL. This design option allowed to install the Enventure SEL even with concerns about the cement job quality. Due to this reason no detailed evaluation of cement quality was performed, which would help to interpret the simulation results.

On the other hand due to the given job parameters, to case the depleted formation out of a milled 9 5/8" casing string, the Baker system could not be applied. Furthermore considering the fact that it was not possible to run the liner to the desired setting depth the Baker system would face its limits. To install the liner it has to be accurately placed in the recess shoe of the base casing, otherwise it is impossible to hang or cement the SEL.

So for this particular situation the Enventure SEL was the only option. For further comparable projects the author recommends the installation of rigid centralizer. Although the API recommendations could not be fulfilled, the standoff is at least improved compared to a non centralized option and this will definitely boost the cementation quality. Furthermore, considering the problems to reach setting depth the installation of centralizers might also contribute for the drag situation.

## Discussion

The currently available SET technology allows the drilling engineer to reduce or even eliminate the tapering effect (telescopic profile) of the conventional casing string design, preserving hole-size. This can either be achieved by implementing SET products in the initial planning of the casing program or by utilizing SETs as a contingency device, which is implemented to handle troubles during the drilling operations. As a result the reach capability of the conventional casing design is increased, while preserving the necessary diameter the target has to be penetrated.

From the standpoint of cost efficiency, outlined in several studies such as SPE-102929 by D.Tabbs et. al., slimming down the wellbore reduces the costs at several points. The achievable cost savings using SET based slimming of the wellbore have been estimated to be 15-20 [%], compared to a conventional casing design.

Even with the extreme economic uncertainty of the past years and the strong fluctuations in energy prices the further need for hydrocarbons show little sign of waning. Contemporaneously the conventional reservoirs which can be developed and produced based on well proved, cheap and simple technologies diminish, while on the other hand the further demand seems to increase dramatically over the next years as outlined by the International Energy Agency (World Energy Outlook 2010 – OECD/IEA).

To cover the future global hydrocarbon demand, new technology able to improve well construction process in economic and technical matter of sense are boosted by marked related advances in energy price.

Especially the SEL technology, with a high further development potential and an increasing number of applications, is considered to be part of this trend (ETF meeting, June 2010 Stavanger).

But never the less, even the currently market leading products investigated do have a number of limitations and disadvantages, restricting the application area and depicting further need for improvements. The goal is to combine the SEL advantages with the technological level reached with the normal liner, to gain an alternative which represents an integral technological advance.

One major consideration is the zonal isolation via cementation, as due to the SEL design characteristics the standard cementation procedures, supporting techniques and good practices have to be at least adapted our can't even be applied.

To optimize the cementation the entire process has to be investigated, starting with the wellbore preparation and conditioning, ranging over string centralization and slurry design up to cement placement optimization. The measures identified include simple compliance of good practices known from cementation of conventional liners, such as full gauge drilling, efficient hole-cleaning and displacement, as well as setting up new targets for cement property design and the related adaption of measurement procedures to guaranty accurate cement characteristics.

As the major technical limitation predominately affecting the cementation efficiency of the commercial SEL applications, the leak of centralization was identified.

Generally a standoff above the recommendation given by the specifications of the American Petroleum Institute are favorable, but each decrease in eccentricity improves the annular flow conditions, which subsequently enhances the wellbore preparation (conditioning) and cement placement quality.

This fact was recognized by the industry and caused the development of centralization devices, aimed to be installed on SEL strings. Due to SET underlying technical concept and the resulting limitations, the centralizers have to be low clearance devices, able to join the expansion process without causing any destruction on the casing or constricting the expansion process while maintaining or generating centralization capabilities.

Based on adaptations of available techniques and new inventions the first designs for the investigated SEL products are currently available.

Founding on the design characteristics of the SEL products different strategies have been followed to develop a functional and effective centralizer.

For the Enventure SEL system, which is the most commonly applied one, the cement is placed pre expansion. Centralization aimed to optimize cement placement has to be achieved preliminary to the expansion and rely on the adaption of a rigid centralizer design. This centralizer is based on a special metal based material which can be glued on the string in almost any shape and thickness. This allows to optimum exploit the low annular clearance during the liner setting. Within the expansion the centralizer doesn't negatively influence the process while maintaining the centralization capability.

The standoff simulation over a range of different inclinations, effective hole-diameters and spacings show that a SEL string in the pre expanded state, with the mentioned kind of centralizers, will not reach the standoff recommendation of API. Only in the post expanded state, under standoff supporting conditions and with an ultra low spacing this target can be reached. But never the less, as the cement is placed and the hole conditioned preliminary to the expansion, the initial standoff is considered to be determinant for the cementation efficiency.

Although the mentioned boundary value of 67% cannot be reached with the currently available centralizer, a significant improvement compared to the non centralized string was observed. This standoff increase of about 35% under average hole-conditions (average of simulated range) improve the flow behavior in the annulus in terms of cementation and therefore positively affect the zonal isolation. Therefore from the author's point of view and from a pure technical standpoint the application of centralizers is recommendable.

The second SEL product investigated, offered by Baker Hughes, employs centralizers following another design strategy. As the cementation and final hole-conditioning is performed post expansion, centralization is required after the expansion process. So a centralizer based on a bow type design was engineered to develop centralization capabilities with the expansion process. During the setting the device is attached tightly on the SEL string, considering the low annular clearance.

As the deflection thickness is related to mechanical process which is activated after the string passed the low clearance of the base casing, the oversize of the centralizer is not limited by the drift. The result is a higher centralization capability of the baker system which is confirmed by the simulation results. Under average hole-conditions a standoff above the limit of 67% can be observed, even for larger spacings.

Based on centralization considerations the second system is definitely favorable it provides the recommended standoff, almost over the entire range of conditions simulated, and even maintains a margin to reduce the necessary spacing.

But it has to be outlined that, not only regarding the centralization, the system is more complex in terms of mechanical components, increasing the potential risk of system failure during the installation. Furthermore the system requires a higher lead time as the decision for application, due to system design reasons, has to be made before the base casing is run. From an integral point of view the system may be predominately favorable for applications in which good zonal isolation is of special interest, as long as the system hasn't proofed reliability in further applications.

For the practical application investigated the cementation job was considered to be non critical. The Enventure system was applied. At the date of execution the centralization option, as mentioned above, was not available, so the string was run without centralization. As far as It was determined the cementation was however successful. But nevertheless the real well data allow the standoff simulation based on less simplified input.

The results confirm the initial simulation. With the application of centralizers the standoff of the Enventure SEL string would, as a maximum, reach an average of 32% compared to less than 10% for the non-centralized one. With the system by Bake Hughes, combined with the related centralizers a maximum average standoff of 78% was evaluated.

But due to the well situation and the design characteristics of the Baker product was only a theoretical option.

Nevertheless even an increase up to 32 % would justify the application of centralizers if the cementation quality is considered to be an issue.

Finally it can be outlined that the centralization option for SEL strings serve its purpose by boosting the standoff, but values comparable to the technical standards of conventional strings can only be reached partially. Combining the centralization investigations with the general limitations of the SEL systems, the goal of creating an alternative which represents an integral technological advance is not reached with the current state of technology.

## References

- R.B. Stewart, F. Marketz, W.C.M. Lohbeck, SIEP; F.D. Fischer, W. Daves, Institute of Mechanics, Montanuniversität Leoben; F.G. Rammerstorfer, H.J. Böhm, Vienna University of Technology  
“Expandable Wellbore Tubulars”  
Paper 60766-MS presented at the SPE Technical Symposium, 16 October 1999, Dhahran, Saudi Arabia
- American Iron and Steel Institute  
<http://www.steel.org>
- Charles Wick, Raymond F. Veilleux  
“Tool and Manufacturing Engineering Handbook - Volume II Forming”  
Society of Manufacturing Engineering 1998
- Frans J. Klever, SPE, Shell International E&P  
“A Design Strength Equation for Collapse of Expanded OCTG”  
Paper 111742-MS presented at the IADC/SPE Drilling Conference, 4-6 March 2008, Orlando, Florida, USA
- Ana Carolina Caldas Aguiar - Petroleum engineering department/ Federal University of Rio de Janeiro, Brazil  
“Strength Analysis of Expandable Tubular for Well Applications”  
Paper 120193-STU presented at the SPE Annual Technical Conference and Exhibition, 21–24 September 2008, Denver, Colorado, USA
- Colin G. Ruan and William C. Maurer, Maurer Technology Inc., A Noble Corporation Subsidiary  
“Analytical Model for Casing Expansion”  
Paper 92281-MS presented at the SPE/IADC Drilling Conference, 23-25 February 2005, Amsterdam, Netherlands
- Chuck Butterfield, Sarah Flaming, Rodger Lebedz, and Michael Thigpen, Enventure Global Technology, and Rick Hill, EWI  
“Understanding Post-Expansion Properties of Solid Expandable Tubulars”  
Paper 110622-MS presented at the SPE Annual Technical Conference and Exhibition, 11-14 November 2007, Anaheim, California, U.S.A.
- Colin G. Ruan and William C. Maurer, Maurer Technology Inc., A Noble Corporation Subsidiary  
“Analytical Model for Casing Expansion”  
Paper 92281-MS presented at the SPE/IADC Drilling Conference, 23-25 February 2005, Amsterdam, Netherlands
- A.C. Seibi, T. Pervez, S. Al-Hiddabi, A. Karrech  
“Finite Element Modeling of a Solid Tubular Expansion – A Typical Well Engineering Application”  
Paper 84943-MS  
2005. Society of Petroleum Engineers

- T. Pervez, Sultan Qaboos U.; A.C. Seibi, Petroleum Inst.; S.A. Al-Hiddabi, F.K. Al-Jahwari, and S.Z. Qamar, Sultan Qaboos U.; and F. Mrketz, Petroleum Development Oman  
 “Solid Tubular Expansion in Horizontal Wells”  
 Paper 105704-MS presented at the SPE Middle East Oil and Gas Show and Conference, 11-14 March 2007, Kingdom of Bahrain
- D. Tubbs, Leor Energy, and Joe Wallace, Enventure Global Technology  
 “Slimming the Wellbore Design Enhances Drilling Economics in Field Development”  
 Paper 102929-MS presented at the SPE Annual Technical Conference and Exhibition, 24-27 September 2006, San Antonio, Texas, USA tr
- Wael El-Mofty and Mark Rivenbark, Enventure Global Technology  
 “Attaining Performance, Deliverability and Cost-Effectiveness With Solid Expandable Tubular Systems”  
 SPE 107915-MS presented at the SPE/IADC Middle East Drilling and Technology Conference, 22-24 October 2007, Cairo, Egypt
- Chris Carstens, SPE, Chevron Corp., and Kate Strittmatter, SPE, Enventure Global Technology LLC  
 “Solid Expandable Tubular Technology: The Value of Planned Installation vs. Contingency”  
 Paper 92622-PA presented at the 2006. Society of Petroleum Engineers
- Mark Holland, Iain Jennings, and Markus Kaschke, Enventure Global Technology  
 “Solid Expandable Tubulars Deliver on Promise and Potential”  
 Paper 110722-MS presented at the Asia Pacific Oil and Gas Conference and Exhibition, 30 October-1 November 2007, Jakarta, Indonesia
- Carl F. Stockmeyer, Bryan Storey, and Alan Brent Emerson, Baker Oil Tools  
 “Expandable Monobore Drilling Liner Extension Technology: Development, Applications and Implementations Following the First Commercial Introduction and Deployment”  
 Paper 113901-MS presented at the Europec/EAGE Conference and Exhibition, 9-12 June 2008 2008, Rome, Italy
- Kenneth K. Dupal, Shell Deepwater Development, Inc.; Donald B. Campo, Shell Exploration & Production Technology; John E. Lofton, Chevron Petroleum Technology Company; Don Weisinger, BP; R. Lance Cook, Michael D. Bullock, Thomas P. Grant, Patrick L. York, Enventure Global Technology, L.L.C.  
 “Solid Expandable Tubular Technology - A Year of Case Histories in the Drilling Environment”  
 Paper 67770-MS presented at the SPE/IADC Drilling Conference, 27 February-1 March 2001, Amsterdam, Netherlands
- Larry Moran, SPE, ConocoPhillips Company, and Mark Savery, SPE, Halliburton  
 “Fluid Movement Measurements Through Eccentric Annuli: Unique Results Uncovered”

Paper 109563-MS presented at the SPE Annual Technical Conference and Exhibition, 11-14 November 2007, Anaheim, California, U.S.A.

- I.A. Frigaard, University of British Columbia; S. Pelipenko, Schlumberger Effective and “Ineffective Strategies for Mud Removal and Cement Slurry Design”  
Paper 80999-MS presented at the SPE Latin American and Caribbean Petroleum Engineering Conference, 27-30 April 2003, Port-of-Spain, Trinidad and Tobago
- Azouz, Idir, U. of Tulsa; Shirazi, S.A., U. of Tulsa; Pilehvari, Ali, U. of Tulsa; Azar, J.J., U. of Tulsa  
“Numerical Simulation of Laminar Flow of Newtonian and Non-Newtonian Fluids in Conduits of Arbitrary Cross-Section”  
Paper 24406-MS  
1992. Society of Petroleum Engineers
- Holger Kinzel, SPE, Weatherford Oil Tool GmbH, and Angelo Calderoni, SPE, Agip SpA  
“Field Test of a Downhole-Activated Centralizer To Reduce Casing Drag”  
Paper 26752-PA  
1995. Society of Petroleum Engineers
- Rashid Abdul Rahman, BJ Services Company; Ahmad Humaizy Zulkafly, Petronas Carigali Sdn Bhd  
“Issues and Solutions for Cementing Expandable Liners: A Case History”  
Paper 87211-MS presented at the IADC/SPE Drilling Conference, 2-4 March 2004, Dallas, Texas
- Charles “Joey” Fanguy, Dan T. Mueller, Dale R. Doherty, BJ Services Company  
“Improved Method of Cementing Solid Expandable Tubulars”  
Paper 90923-MS presented at the SPE Annual Technical Conference and Exhibition, 26-29 September 2004, Houston, Texas
- C.F. Stockmeyer, D.L. Tillman, and J.B. Weirich, Baker Oil Tools, and Z. Sehnal, Statoil  
“Development and Commercial Deployment of an Expandable Monobore Liner Extension”  
Paper 102150-MS presented at the SPE Annual Technical Conference and Exhibition, 24-27 September 2006, San Antonio, Texas, USA
- H.M. Al-Balushi, M.H. Al-Rashdi, M.H. Al-Shandoodi, Petroleum Development Oman; R.H. VanNoort, Shell International Exploration and Production  
“World's Longest Expandable Open Hole Clad and Open Hole Liner with Swelling Elastomer Deployed in Yibal Horizontal Well”  
Paper 88026-MS presented at the IADC/SPE Asia Pacific Drilling Technology Conference and Exhibition, 13-15 September 2004, Kuala Lumpur, Malaysia
- Eduardo Perez-Roca, Enventure Global Technology L.L.C.  
“Optimizing Producing Wells With Solid Expandable Tubular Technology”  
Paper 107932-MS presented at the Latin American & Caribbean Petroleum Engineering Conference, 15-18 April 2007, Buenos Aires, Argentina
- Andrei Filippov, Robert Mack, Shell; Lance Cook, Patrick York, Lev Ring, Enventure Global Technology; Terry McCoy, Halliburton Energy Services



“Expandable Tubular Solutions”

Paper 56500-MS presented at the SPE Annual Technical Conference and Exhibition, 3-6 October 1999, Houston, Texas

- Matthew Jabs, Baker Hughes Inc., Baker Oil Tools Division  
“World's First Expandable Monobore Well System: Development, Implementation, and Significance”  
Paper 11587-MS presented at the International Petroleum Technology Conference, 4-6 December 2007, Dubai, U.A.E.
- Carl F. Stockmeyer, Mark K. Adam, and Alan B. Emerson, Baker Oil Tools, and Robert V. Baker and Robert B. Coolidge, BP  
“Expandable-Drilling-Liner Technology: First Commercial Deployment of a Monobore Liner Extension”  
Paper 108331-MS presented at the Offshore Europe, 4-7 September 2007, Aberdeen, Scotland, U.K.
- S.A. McPherson, BJ Services Co. Ltd.  
“Cementation of Horizontal Wellbores”  
Paper 62893-MS presented at the SPE Annual Technical Conference and Exhibition, 1-4 October 2000, Dallas, Texas
- Rustom Mody, SPE, Baker Hughes Inc., Division: Baker Oil Tools  
“Enabling Our Enabling Technologies: What will it take, and what is at Stake?”  
Paper 113442-MS presented at the Europec/EAGE Conference and Exhibition, 9-12 June 2008, Rome, Italy
- Matthew Jabs, Baker Oil Tools  
“Using Expandable Metal Technology to Create a Monobore Well”  
Paper 16670-MS presented at the Offshore Technology Conference, 3 May-6 May 2004, Houston, Texas
- Hitoshi Asahi, Ejji Tsuru, Takashi Motoyoshi, Hidefumi Tsugihara, and Itsuro Hiroshige, Nippon Steel Corp.  
“Effect Of Metallurgical Factors On Expandability And Mechanical Properties After Expansion For Expandable Tubulars”  
Paper 05121 presented at the CORROSION 2005, April 3 - 7, 2005, Houston, Tx
- W. H. Bagley and Don Schultz, Nexen Petroleum U.S.A., Inc.; Joe Mueller, Marcus Vondenstein, and Harsh Chowdhary, Enventure Global Technology, L.L.C.  
“Solid Expandable Tubular System Mitigates High-Pressure Zones with Record Length”  
Paper 112756-MS presented at the IADC/SPE Drilling Conference, 4-6 March 2008, Orlando, Florida, USA
- Doug G. Durst, SPE, and Neven Ruzic, SPE, Enventure Global Technology  
“Expandable Tubulars Facilitate Improved Well Stimulation and Well Production”  
Paper 121147-MS presented at the SPE Western Regional Meeting, 24-26 March 2009, San Jose, California

- Tom Sanders, Weatherford Int'l, Shaohua Zhou, Saudi Aramco, Patrick York, Weatherford Int'l; Thomas Joulaud, VALLOUREC & MANNESMANN OIL & GAS, France; Jeffrey Teo and Raju Gandikota, Weatherford Int'l .  
"Installation and Operational Performance of Horizontal Solid Expandable Openhole Production Liners in Maximum Reservoir Contact Wells – Case Histories"  
Paper 124965-MS presented at the SPE Annual Technical Conference and Exhibition, 4-7 October 2009, New Orleans, Louisiana
- J. Agata, E. Tsuru, M. Sawamura, H. Asahi, and H. Tsugihara, Nippon Steel Corporation  
"Evaluating the Expandability and Collapse Resistance of Expandable Tubulars"  
Paper 119552-MS presented at the SPE/IADC Drilling Conference and Exhibition, 17-19 March 2009, Amsterdam, The Netherlands
- H.M. Al-Balushi, M.H. Al-Rashdi, M.H. Al-Shandoodi, Petroleum Development Oman; R.H. VanNoort, Shell International Exploration and Production  
"World's Longest Expandable Open Hole Clad and Open Hole Liner with Swelling Elastomer Deployed in Yibal Horizontal Well"  
Paper 88026-MS presented at the IADC/SPE Asia Pacific Drilling Technology Conference and Exhibition, 13-15 September 2004, Kuala Lumpur, Malaysia
- Mohammed I. Al-Umran, Ibrahim A. Al-Obaidi, Shaohua Zhou, and Abdulmohsin Al-Nassir, SPE, Saudi Aramco  
"Solid Expandable Tubular Technology Applications in Saudi Arabia: Lessons Learned"  
Paper 111871-MS presented at the IADC/SPE Drilling Conference, 4-6 March 2008, Orlando, Florida, USA
- Melvin Moore, and Jesse Lopez, BP-Egypt; Edgar Chacon, Ron Nida, and Arshad Waheed, Halliburton  
"First Application of New Expandable Liner Hanger Technology in Deepwater HP/HT Well of Egypt"  
Paper 112859-MS presented at the SPE North Africa Technical Conference & Exhibition, 12-14 March 2008, Marrakech, Morocco
- Adam T. Bourgoyne Jr., Keith K. Millheim, Martin E. Chenevert, F.S. Young Jr.  
Applied Drilling Engineering (Spe Textbook Series, Vol 2)  
Second Printing Society of Petroleum Engineers Richardson, TX 1991
- Dipl.-Ing. Wolfgang F. Prassl, Curtin University of Technology  
Drilling Engineering  
Curtin University of Technology Department of Petroleum Engineering
- Carl Gatlin ,University of Texas  
Petroleum Engineering – Drilling and Well Completion  
Department of Petroleum Engineering University of Texas
- IADC Drilling Manual  
Copyright© 2000, International Association of Drilling Contractors
- Standard Handbook of Petroleum & Natural Gas Engineering Volume 1 and 2

William C. Lyons, PH.D., P.E. Editor  
Gulf Publishing Company 1996

- Erik B. Nelson et.al.  
Well Cementing  
Schlumberger Education Service 1990
- Michael J. Economides, Larry T. Watters, Shari Dunn-Norman  
Petroleum Well Construction  
Wiley (June 18, 1998)
- Petroleum Engineering Handbook – Volume II Drilling Engineering  
Robert F. Mitchell, Editor  
Society of Petroleum Engineers 2006
- Cold Forming of Steel  
Wei-Wen Yu  
John Wiley & Sons Inc. 2000
- Hans Albert Richard, Manuela Sander  
Technische Mechanik. Festigkeitslehre  
GWV Fachverlag GmbH, Wiesbaden 2008
- World Energy Outlook 2010  
OECD/IEA

# Appendix A

## List of Figures

Figure 01: Idealized Stress-Strain curve of metal under axial load – SPE 60766, R.B. Stewart et.al

Figure 02: True and Engineering Stress-Strain curve - American Iron and Steel Institute

Figure 03: True Stress-Strain curve with a LOG-LOG scale - American Iron and Steel Institute

Figure 04: Impact of ductility on Stress-Strain curve & spring back indication after stress release – Tool and Manufacturing Engineering Handbook, Charles Wick et. al.

Figure 05: Steel Materials with different yield strength

Figure 06: Stress-Strain curve visualizing the “Bauschinger Effect” - SPE92281-MS, Colin G. et. al.

Figure 07: Figure of pre and post expansion stress and strain curves of set materials for different axial and load directions – SPE111742, Fans J. Klever et. al.

Figure 08: Different failure modes for pipe collapse as a function of D/t – Petroleum Well Construction, Michael J. Econmides et. al.

Figure 09: Impact of SET technology on casing string design – SPE 67770, Kenneth K. Dupal et.al.

Figure 10: Pore pressure and fracture pressure prediction displays as ECD creating a operational mud weight window used to evaluate number and setting depth of casing strings. - Petroleum Well Construction, Michael J. Econmides et. al.

Figure 11: Mud weight window slimming effect due to hole-angle increase - Petroleum Well Construction, Michael J. Econmides et. al.

Figure 12: Effect of water depth on effective mud weight - Drilling Engineering III / deepwater drilling, M. Doschek, 2008

Figure 13: Typical graphic tool to evaluate the casing string section diameters based on a fixed prod casing size; todays additional intermediate sizes allow to increase number of strings for conventional designs from 5 up to 9 sections. - Petroleum Well Construction, Michael J. Econmides et. al.

Figure 14-15: Two examples how SETs extend the reach capability by increasing the number of strings while maintaining hole size – SPE92622, Chris Carstens et. al.

Figure 16: Rigid body (inflexible) expansion cone – Solid Expandable Tubular Applications, Brent Emmerson (Baker Hughes/2004) et. al.

Figure 17: Inflatable (flexible) expansion cone – Expandable Monobore Drilling Liner Extension Technology, Carl Stockmeyer (Baker Hughes/2009) et. al.

Figure 18: Hydraulic Anchor – Solid Expandable Tubular Applications, Brent Emmerson (Baker Hughes/2004) et. al.

Figure 19: Hydraulic Stroker in extended position – Expandable System Overview, Carl Stockmeyer (Baker Hughes/2007) et. al.

Figure 20: Retrievable Guide Shoe - Beyond World’s first Monobore Liner Extension, David Baley (Baker Hughes/2007) et.al.

Figure 21: RC9/Recess Shoe - SPE113901, Carl F. Stockmeyer et. al.

Figure 22: RC9 Recess Shoe - Expandable Monobore Drilling Liner Extension Technology, Carl Stockmeyer (Baker Hughes/2009) et. al.

Figure 23: Composite Pipe - Expandable Monobore Drilling Liner Extension Technology, Carl Stockmeyer (Baker Hughes/2009) et. al.

Figure 24: System operational sequence - Expandable Monobore Drilling Liner Extension Technology, Carl Stockmeyer (Baker Hughes/2009) et. al.

Figure 25: Major components of the bottom up expansion system – How SET Technology Work, Enventure Global Technology/2009

Figure 26: System operational sequence - SPE 67770, Kenneth K. Dupal et.al.

Figure 27: Contingency Recess Shoe / with sliding sleeves in open and closed position - Expandable Monobore Drilling Liner Extension Technology, Carl Stockmeyer (Baker Hughes/2009) et. al.

Figure 28: Cement placement procedure for post expansion cement placement procedure position – Expandable System Overview, Carl Stockmeyer (Baker Hughes/2007) et. al.

Figure 29: Cement placement procedure for post expansion cement placement procedure position – Expandable System Overview, Carl Stockmeyer (Baker Hughes/2007) et. al.

Figure 30: Cement placement procedure for pre expansion cement placement procedure – Bottom Up Expansion - SPE 67770, Kenneth K. Dupal et.al.

Figure 31: Schematic of a 100% centralized casing string – P. Fischer

Figure 32: Schematic of a an eccentrd casing string – P. Fischer

Figure 33: Flow velocity profile of a Bingham fluid in an eccentric annulus. - Petroleum Well Construction, Michael J. Econmides et. al.

Figure 34: Conventional bow spring centralizer – SledgeHammer Oil Tools Pvt. Ltd.

Figure 35: Conventional rigid centralizer – SledgeHammer Oil Tools Pvt. Ltd.

Figure 36: The close tolerance expandable centralizer schematic and picture - Expandable Monobore Drilling Liner Extension Technology, Carl Stockmeyer (Baker Hughes/2009) et. al.

Figure 37: Rigid centralizers made of spray metal able to withstand pipe expansion without loosing centralization capability / recommended by SEL providers – Montage Protech Centralizers, RWE Dea AG, Halliburton-Protech

Figure 38: Real time data of an expansion process indicating the periodic sequence of the expansion – RWE Dea AG

Figure 39: Inclination variation from planed vertical survey – y axis represents plan inclination

Figure 40: Azimuth variation from planed vertical survey – y axis represents plan azimuth

Figure 41: Inclination variation from planed horizontal survey – y axis represents plan inclination

Figure 42: Azimuth variation from planed horizontal survey – y axis represents plan azimuth

Figure 43: Inclination variation from planed inclined surveys – y axis represents plan inclination

Figure 44: Azimuth variation from planed inclined surveys – y axis represents plan azimuth

Figure 45: One standoff profile as typical simulation output – Pre- and Post-Expansion for a centralized SEL string with arithmetic average

Figure 46: Schematic of one pipe segment between two centralizers [PID-Pipe Inner Diameter; POD-Pipe Outer Diameter; CD-Centralizer Diameter; OHD-Open Hole Diameter; Wt-Pipe Weight per Unit Length; E-Pipe Young's Module;  $\delta_n$ -Sag Profile;  $\delta_{max}$ -Maximum Sag;  $\rho_i$ -Liquid Density inside the Pipe;  $\rho_o$ -Liquid Density outside the Pipe; w-Liftoff at Centralizer; S-Centralizer Spacing] – P. Fischer

Figure 47: Idealized beam section with boundary criterions [ $\delta_x$ -Sag Profile;  $\delta_{max}$ -Maximum Sag; S-Centralizer Spacing; F-Tangential Force – P. Fischer

Figure 48: Schematic of model for the evaluation of the tangential forces used to calculate the section sag - Petroleum Well Construction, Michael J. Econmides et. al.

Figure 49: Pipe body distance from wellbore wall at maximum sag – P. Fischer

Figure 50: Processing of the position analyses – Landmark Help Manual

Figure 51: Schematic sketch of string position plus geometrical considerations to evaluate the standoff for one node – P. Fischer

Figure 52: Schematic of the wellbore prepared for Enventure system – P. Fischer

Figure 53: Schematic of the wellbore prepared for Baker system– P. Fischer

Figure 54: Inclination of the investigated open-hole section

Figure 55: Azimuth of the investigated open-hole section

Figure 56: Dog-leg severity and absolute tortuosity of the investigated open-hole section

Figure 57: Fluid columns in annulus and SEL string of pre-expanded Enventure SEL after cement program was pumped – P. Fischer

Figure 58: Fluid columns in annulus and SEL string of post-expanded Enventure SEL after cement program was pumped – P. Fischer

Figure 59: Fluid columns in annulus and SEL string of post-expanded Baker SEL after cement program was pumped – P. Fischer

Figure 60: Pre expansion standoff values for the Enventure SEL string with centralizers installed (multiple spacings) and without centralizers installed across the desired open-hole section between 7290 feet and 8858 feet measured depth in wellbore A/a

Figure 61: Post expansion standoff values for the Enventure SEL string with centralizers installed (multiple spacings) and without centralizers installed across the desired open-hole section between 7290 feet and 8858 feet measured depth in wellbore A/a

Figure 62: Pre expansion standoff values for the Enventure SEL string across the desired open-hole section between 7290 feet and 8858 feet measured depth in wellbore A/a; comparison of optimized profile with a homogeneous spacing of 45 [ft]

Figure 63: Post expansion standoff values for the Enventure SEL string across the desired open-hole section between 7290 feet and 8858 feet measured depth in wellbore A/a; comparison of optimized profile with a homogeneous spacing of 45 [ft]

Figure 64: Pre expansion standoff values for the Baker SEL string across the desired open-hole section between 7290 feet and 8858 feet measured depth in wellbore A/a

Figure 65: Post expansion standoff values for the Baker SEL string with centralizers installed (multiple spacings) and without centralizers installed across the desired open-hole section between 7290 feet and 8858 feet measured depth in wellbore A/a

Figure 66: Post expansion standoff values for the Baker SEL string across the desired open-hole section between 7290 feet and 8858 feet measured depth in wellbore A/a; comparison of optimized profile (33 centralizers) with a homogeneous spacing of 30 [ft] (51 centralizers)

## List of Tables

Table 01: Impact of Stain Hardening Coefficient “n” onto expansion ration of different steel materials analytically calculated - SPE 60766, R.B. Stewart et.al

Table 02: Quantitative indication of expansion caused changes of YS and TS in axial compression and tension direction and circumferential tensional and compressional direction

Table 03: Ttime estimate of an operational sequence of cement placement for a 620 feet SEL string

Table 04: Open-Hole specifications

Table 05: Open-Hole tortuosity and dogleg specifications

Table 06: Equivalent Open-Hole diameters to specify hole quality variations

Table 07: Enventure SEL string specifications

Table 08: Specifications of SEL centralizers recommended by Enventure

Table 09: Cement Program implemented in Standoff simulation

Table 10: Baker SEL string specifications

Table 11: Specifications of SEL centralizers recommended by Baker

Table 12: Cement Program implemented in Standoff simulation

Table 13: Survey of solid expandable liner open-hole target section

Table 14: SEL string specifications for wellbore A/a – Enventure system

Table 15: Specifications of SEL centralizers available for the Enventure system

Table 16: Baker SEL string specifications

Table 17: Specifications of SEL centralizers recommended by Baker

Table 18: Depth range evaluation for standoff optimization

Table 19: Evaluated depth range with selected spacing

Table 20: optimization results

Table 21: Optimized Spacing across SEL string

## List of Equations

Equation 01-04: Evaluation process of Strain hardening Coefficient “n” based on a tensile strength test

Equation 05: Rule of thumb for the evaluation of spring back after circumferential expansion

Equation 06: Young’s Modulus

Equation 07: Empirical equation to evaluate expansion capability for pressure induced forming process - SPE60766, R.B. Stewart et.al

Equation 08: Empirical equation to evaluate expansion capability for strain controlled expansion process- SPE60766, R.B. Stewart et.al

Equation 09: Energy balance of the pipe expansion process

Equation 10 - 13: Calculation to evaluate the force required to expand a pipe – pL evaluated based on implementation of equation 10 - 12 into equation 09

Equation 14-15: Pipe eccentricity and standoff calculation

Equation 16: Bearden unit of Consistency

Equation 17-18: Sag Profile and maximum Sag based on fixed end criterion – S. Robello Halliburton

Equation 19-20: Model for the evaluation of the tangential forces used to calculate the section sag

Equation 21-22: calculation approach used to evaluate Standoff at point of maximum sag

Equation 23-24: Sketch of string position with the related geometrical considerations to evaluate the Standoff for one node