

# **Master Thesis**

For the acquisition of the academic degree  
Master of Science (Diplom-Ingenieur, Dipl.-Ing.)  
of the Master Degree Mining  
Master Program Mining and Tunneling  
Major Geotechnics and Tunneling

Submitted to the  
Chair of Subsurface Engineering  
University Leoben

Lisa Mori  
Leoben, August 2012

Topic

# **“Results of Linear Cutting Tests on Different Alpine Lithologies”**

**Statutory Declaration**

I declare in lieu of oath, that I wrote this thesis and performed the associated research myself, using only literature cited in this volume.

(Signature)

---

Date, Place

---

Name

## **Note of Thanks**

I want to thank

Galler, Robert, Univ.-Prof. Dipl.-Ing. Dr.mont., who encouraged me to go to the Colorado School of Mines to perform the tests for my Master Thesis.

Lasnig, Klaus, Mag.rer.nat., my Master Thesis co-advisor.

The Colorado School of Mines, the staff of the Earth Mechanics Institute and the EMI manager Brian Asbury for helping me through the testing procedure.

Frenzel, Christian, Univ.-Prof. Dr., who was my first contact at the School of Mines and my advisor during my time there.

My friends and colleagues at the University of Leoben, which made studying the great experience it was to me.

My family for always supporting my goals in life and never doubting my ability to study and work as an engineer.

## **Abstract**

For this thesis linear cutting tests were carried out to analyze what influence rock type, foliation direction, penetration and spacing has on the cutting forces, grain sizes, aspect ratio and specific energy.

Rock cubes were cut from the rock types calcareous mica schist, augen gneiss and schistose gneiss with multiple foliation directions and were cast in concrete. The foliation directions of calcareous mica schist are perpendicular, parallel, oblique and massive. Those of augen gneiss are perpendicular, parallel and oblique and that of schistose gneiss is oblique.

Four different spacing-penetration combinations were used to cut the rock cubes on the Linear Cutting Machine. The cutting forces were measured during the tests and samples of the excavated material were taken to analyze for grain sizes and aspect ratios.

The trends of the forces, the grain sizes, the aspect ratios and the specific energy based on the testing parameters are explained and interpreted. It can be determined that the rock type has an influence on the normal forces, the grading curves and the aspect ratios. The foliation direction has influence on the normal forces, the specific energy and the aspect ratios. Furthermore it can be confirmed that the spacing has an effect on the grading curves and the aspect ratios. The penetration only has an influence on the normal forces.

## **Zusammenfassung**

Für diese Arbeit wurden Linearschneidversuche durchgeführt um zu analysieren welchen Einfluss Gesteinstyp, Schieferungsrichtung, Penetration und Schneidspurabstand auf die Schneidkräfte, die Korngrößen, die Kornform und die spezifische Energie haben.

Gesteinswürfel wurden aus den Gesteinsarten Kalkglimmerschiefer, Augengneis und Schiefergneis mit mehreren Schieferungsrichtungen geschnitten und in Beton gegossen. Die Schieferungsrichtungen von Kalkglimmerschiefer sind rechtwinkelig, parallel, winkelig und massig. Die von Augengneis sind rechtwinkelig, parallel und winkelig und die von Schiefergneis ist winkelig.

Vier verschiedene Schneidspurabstand-Penetrations-Kombinationen wurden verwendet um die Gesteinswürfel am Linearschneidstand zu schneiden. Die Schneidkräfte wurden während der Tests gemessen und Proben des geschnittenen Materials wurden entnommen um es auf Korngrößen und Kornform zu analysieren.

Die Tendenzen der Kräfte, der Sieblinien, der Kornformen und der spezifischen Energie bezogen auf die verwendeten Versuchparameter werden erklärt und interpretiert. Es kann festgestellt werden, dass die Gesteinsart einen Einfluss auf die Normalkräfte, die Sieblinien und die Kornformen hat. Die Schieferungsrichtung hat Einfluss auf die Normalkräfte, die spezifische Energie und die Kornformen. Außerdem kann auch bestätigt werden, dass der Schneidspurabstand sich auf die Sieblinien und die Kornformen auswirkt. Die Penetration hat nur Einfluss auf die Normalkräfte.

---

## Table of Content

1	Introduction.....	3
2	Literature and State of Art.....	4
2.1	CSM.....	4
2.2	NTNU.....	7
2.3	Gehring.....	9
3	Methods.....	13
3.1	Linear Cutting Machine (LCM).....	13
3.1.1	Machine Description.....	13
3.1.2	Variation of Penetration.....	15
3.1.3	Variation of Spacing.....	16
3.1.4	Variation of Disc Diameter.....	16
3.1.5	Variation of Cutting Velocity.....	16
3.1.6	Specific Energy.....	17
3.2	Rock Samples.....	17
3.2.1	Calcareous Mica Schist.....	18
3.2.2	Augen Gneiss.....	19
3.2.3	Schistose Gneiss.....	19
3.3	Testing Procedure.....	20
3.3.1	Box Preparation.....	20
3.3.2	Cutting Program.....	22
3.3.3	LCM Calibration.....	26
3.4	Forces.....	27
3.5	Sampling.....	28
3.6	Sieve Analysis.....	29
3.7	Aspect Ratio Analysis.....	29
4	Results.....	30
4.1	Cutting Forces.....	30
4.1.1	Calcareous Mica Schist.....	30
4.1.2	Augen Gneiss.....	31
4.1.3	Schistose Gneiss.....	33
4.2	Sieve Analysis.....	33
4.2.1	Calcareous Mica Schist.....	41

4.2.2	Augen Gneiss .....	48
4.2.3	Schistose Gneiss .....	53
4.3	Specific Energy .....	54
4.4	Aspect Ratios .....	56
4.4.1	Calcareous Mica Schist .....	58
4.4.2	Augen Gneiss .....	61
4.4.3	Schistose Gneiss .....	64
5	Conclusion, Interpretation and Discussion.....	67
5.1	Forces .....	67
5.2	Sieve Analysis .....	67
5.3	Specific Energy .....	68
5.4	Aspect Ratios .....	68
6	List of Tables .....	70
7	List of Figures .....	71
8	List of Diagrams .....	72
9	Bibliography.....	75
	Appendix A – Sieve Analysis .....	I
	Appendix B- Aspect Ratios.....	X



## 1 Introduction

The number of TBM driven tunnels increases every year, which, in turn increases the amount of excavated material that must be disposed of. Therefore, the possible avoidance or reduction of the excavation material, which has to be deposited, developed to a considerable topic. The material could be reused as a raw material for various applications, which depend mostly on the properties of the excavated material. Particularly the grain sizes and the aspect ratios have a significant influence of the possible uses of the material. Possible uses of the material range from concrete and asphalt aggregates to filling material and material for the refractory industry. Because of that, a prediction of the expected properties and amount of the material is important for the processing of the material.

This thesis deals with the reuse of excavation material of TBM driven tunnels and therefore with its properties. It refers to and continues the Master thesis of Dipl.-Ing. Florian Biermeier, in which he summarizes the tests on homogeneous Imberg sandstone. In contrast metamorphic lithologies were tested in this thesis to include the influence of foliation directions on the test results. The rock types discussed are calcareous mica schist with the foliation directions oblique, parallel, perpendicular and massive, augen gneiss with the foliation directions oblique, parallel and perpendicular and schistose gneiss with the foliation direction oblique.

To make a prognosis about the influential factors on the use of the materials, linear cutting tests have been carried out at the Earth Mechanics Institute of the Colorado School of Mines. The influential factors that have been looked at are penetration, spacing, rock type and foliation direction. These factors have an effect on the cutting forces, the grain size distribution, the aspect ratios and the specific energy. The results of this thesis as well as those of Biermeier, Wachter, Dreitler and Löscher will be summarized and included in the dissertation of Mag.rer.nat. Klaus Lassnig.

## 2 Literature and State of Art

Penetration is an important factor for the estimation of the performance of TBMs and therefore the prediction of the expected penetration values is necessary. Both the used machine and the excavated rock mass influence the penetration performance. In literature several models for the penetration prediction of TBMs exist and deal with the influence of various factors on the penetration of TBMs. To get an overview of the prediction possibilities three of those penetration prediction models are discussed in this chapter.

### 2.1 CSM

Previous publications [1], [2] indicate that for the Colorado School of Mines-Model the cutting process of single and multiple cuts was analyzed to predict the penetration. The single cuts were used to understand the effect of disc cutters in rock, the induced stresses, the crushed zones and the produced cracks (shown in Figure 1). The formation of cracks is analyzed by making multiple cuts on a rock surface (shown in Figure 2). A chip is formed when the cracks of two adjacent cuts reach each other and depends, next to other parameters, on the tensile strength of the rock.

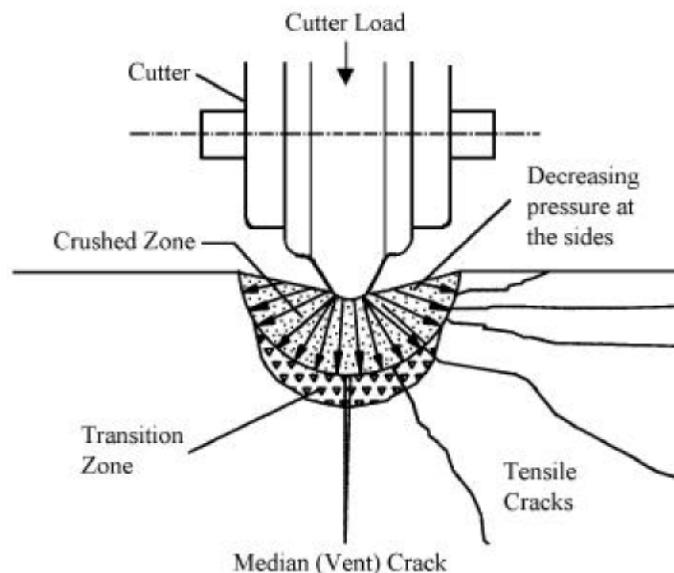

**Figure 1: Breakout process on a single cutter (from [2])**

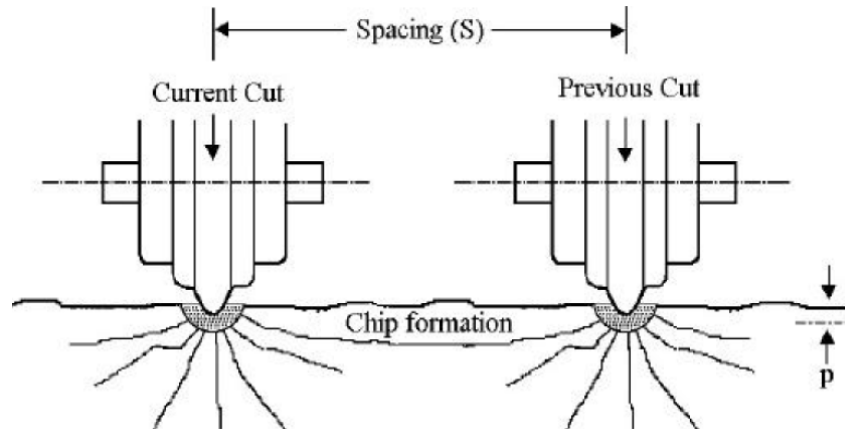

**Figure 2: Chip formation on a multiple cutter (from [2])**

The normal force and the rolling force acting on the disc cutter form the cutter coefficient (CC, see Figure 3):

$$CC = \text{cutter coefficient} = \frac{\text{rolling force}}{\text{normal force}} \quad (1)$$

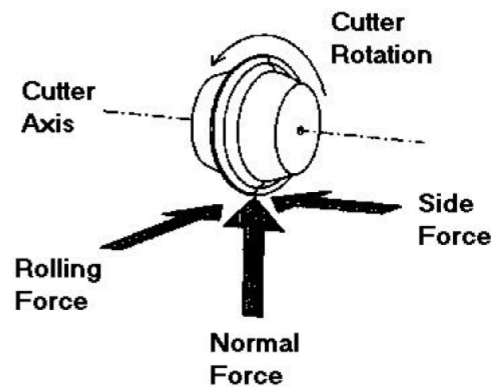

**Figure 3: Forces on disc cutter (from [2])**

The relationship between the penetration and the interacting angle  $\varphi$  between the disc cutter and the rock is (the geometrical relationship is shown in Figure 4):

$$\varphi = \cos^{-1} \frac{R - p}{R} \quad (2)$$

- $\varphi$  ...interacting angle [°]
- R ...radius of disc cutter [mm]
- p ...penetration [mm]

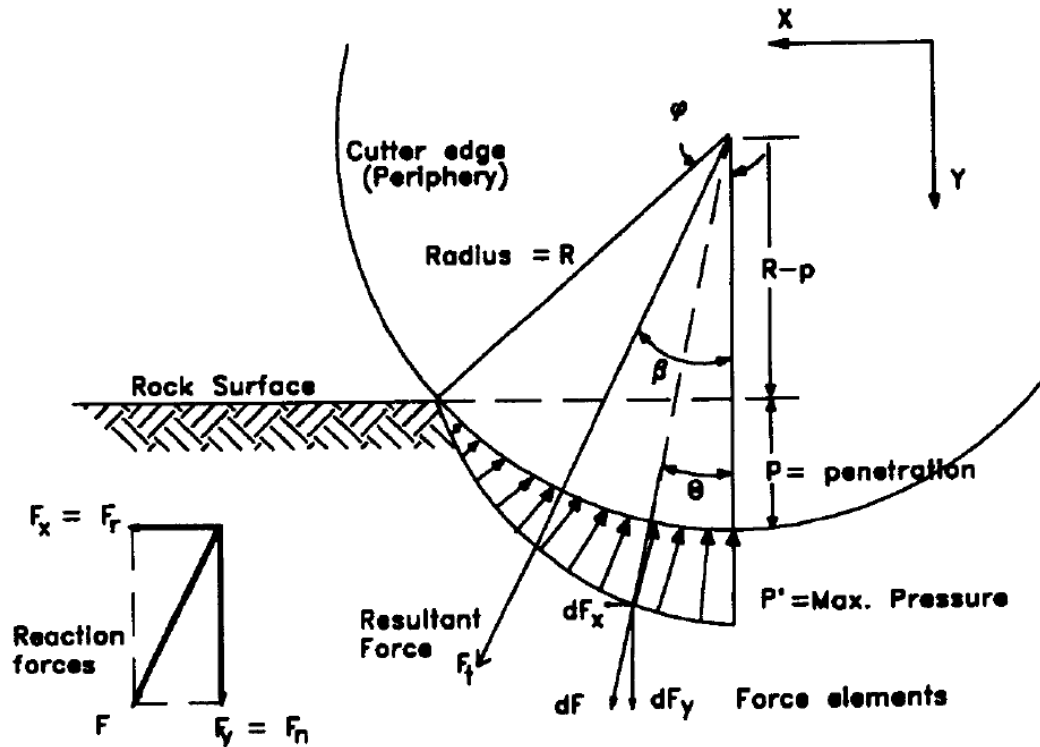

Figure 4: Geometrical relationship between the penetration and the interacting angle  $\varphi$  (from [1])

More geometrical relationships gained from Figure 4:

$$F_n = F_t \cdot \cos \beta \quad (3)$$

$$F_r = F_t \cdot \sin \beta \quad (4)$$

$F_n$  ...normal force [kN]

$F_r$  ...rolling force [kN]

$F_t$  ...resulting force [kN]

$\beta$  ...angle between resulting force and cutting surface [°]

$$CC = \tan \beta = \tan \frac{\varphi}{2} \quad (5)$$

$$F_t = \frac{P' \cdot \varphi \cdot R \cdot T}{1 + \Psi} \quad (6)$$

$P'$  ...pressure of crushed zone [kN/mm<sup>2</sup>]

$T$  ...tip width of cutter [mm]

$\Psi$  ...constant for pressure distribution function [-]

$$P' = 100500 + 12170 \cdot S + 7.88 \cdot \sigma_c - 28830 \cdot \sigma_t^{0.1} - 192 \cdot S^3 - 0.000147 \cdot \sigma_c^2 - 29450 \cdot T - 13000 \cdot R \quad (7)$$

- S ...spacing [mm]  
 $\sigma_c$  ...uniaxial compressive strength [kN/mm<sup>2</sup>]  
 $\sigma_t$  ...tensile strength from Brazilian test [kN/mm<sup>2</sup>]

The equations above are only valid for tests with the rock and cutting parameters shown in Table 1.

Parameter	Range (Metric)	Metrical Unit	Range (Imperial)	Imperial Unit
$\sigma_c$	70-200	MPa	10000-30000	kpsi
$\sigma_t$	4-18	MPa	500-2500	psi
R	39-45	cm	15-18	in
S	5-15	cm	2-4	in
p	0.25-3	cm	0.1-1.5	in

**Table 1: Ranges for rock and cutting parameters used in the equations (from [1])**

A correction of the tip width of the cutter T is also provided:

$$T' = T + w \cdot \tan \frac{\alpha}{2} \quad (8)$$

- T' ...new tip width [mm]  
w ...wear of cutter tip [-]  
 $\alpha$  ...angle of cutter tip [°]

To predict the penetration the expected side parameter is calculated for a range of different penetrations. Possible side parameters are:

- total requested thrust
- torque of the TBM
- rotation per minute
- drilling head capacity

The current penetration can be assumed from the measured side parameters of the TBM.

## 2.2 NTNU

According to Amund [3] looks the Norges Teknisk-Naturvitenskapelige Universitet-Model (NTNU model) at the relationship between the gross thrust per cutter disc and the penetration per cutter head revolution. The two basic parameters of this model are the critical or necessary thrust  $M_1$ , needed to achieve a penetration of 1 mm per cutter head revolution, and the penetration coefficient or penetration exponent b. The relationship between those two parameters is shown in Figure 5.

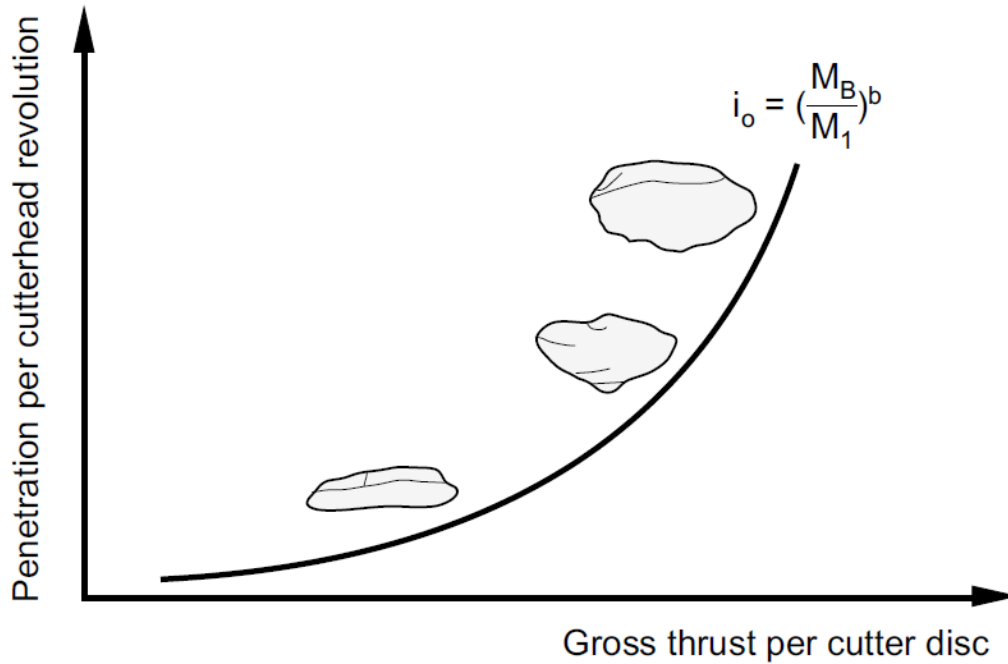

**Figure 5: Penetration per cutter head revolution by gross thrust per cutter disc (from [3])**

Data from various tunnel projects with a total length of 250 km were used to develop the NTNU model. The aim was that the calculated data corresponds as good as possible with the data from the tunnel projects. Rock mass parameters and machine parameters were included in the calculation for that purpose.

The penetration per cutter head revolution  $i_0$  is calculated as follows:

$$i_0 = \left(\frac{M_{eqv}}{M_1}\right)^b \quad (9)$$

$i_0$  ...penetration per cutter head revolution [mm/rev]

$M_{eqv}$  ...equivalent cutter thrust [kN/cutter]

$M_1$  ...critical thrust [kN/cutter]

$b$  ...penetration coefficient [-]

For the calculation of the equivalent cutter thrust, correction factors have to be applied if the cutter diameter differs from 19 inch and if the spacing differs from 70 mm.

$$M_{eqv} = M_B \cdot k_d \cdot k_a \quad (10)$$

- $M_B$  ...average cutter thrust [kN/cutter]  
 $k_d$  ...correction factor for cutter diameter [-]  
 $k_a$  ...correction factor for average spacing [-]

The equivalent fracturing factor  $k_{eqv}$  has to be calculated to determine the critical thrust and the penetration coefficient.

$$k_{eqv} = k_{s-tot} \cdot k_{DRI} \cdot k_{por} \quad (11)$$

- $k_{eqv}$  ...equivalent fracturing factor [-]  
 $k_{s-tot}$  ...total fracturing factor [-]  
 $k_{DRI}$  ...correction factor for the drillability [-]  
 $k_{por}$  ...correction factor for the porosity of the rock [-]

The distance between planes of weakness and their angle to the tunnel axis are taken into account by the total fracturing factor  $k_{s-tot}$ . The factor  $k_{DRI}$  is 1.0 for a DRI (Drill Rate Index) of 50 and the factor  $k_{por}$  is 1.0 for a porosity of 2%.

### 2.3 Gehring

Gehring [4] based his model on the uniaxial compressive strength and the chipping procedure under a disc cutter in different phases as shown in Figure 6.

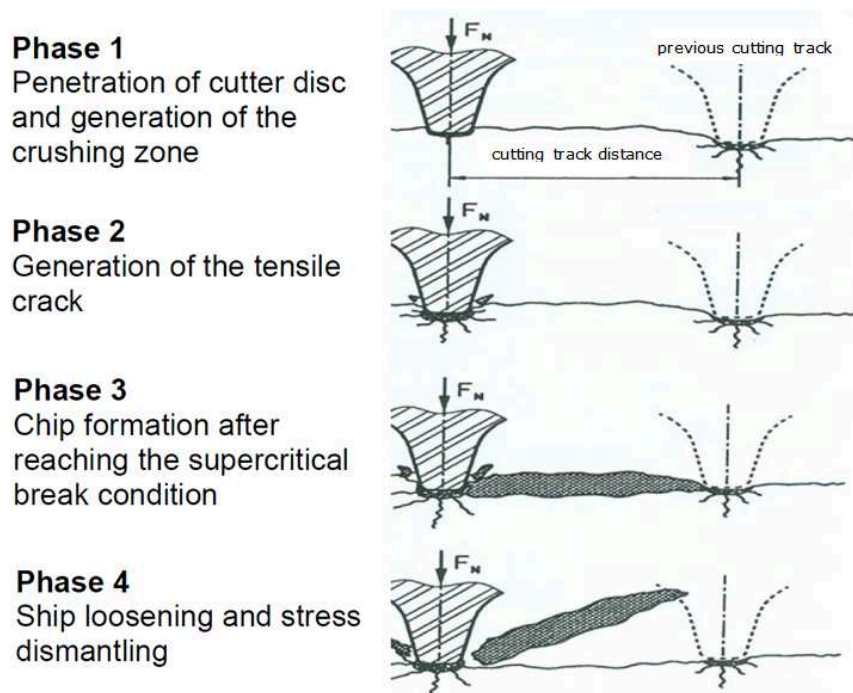
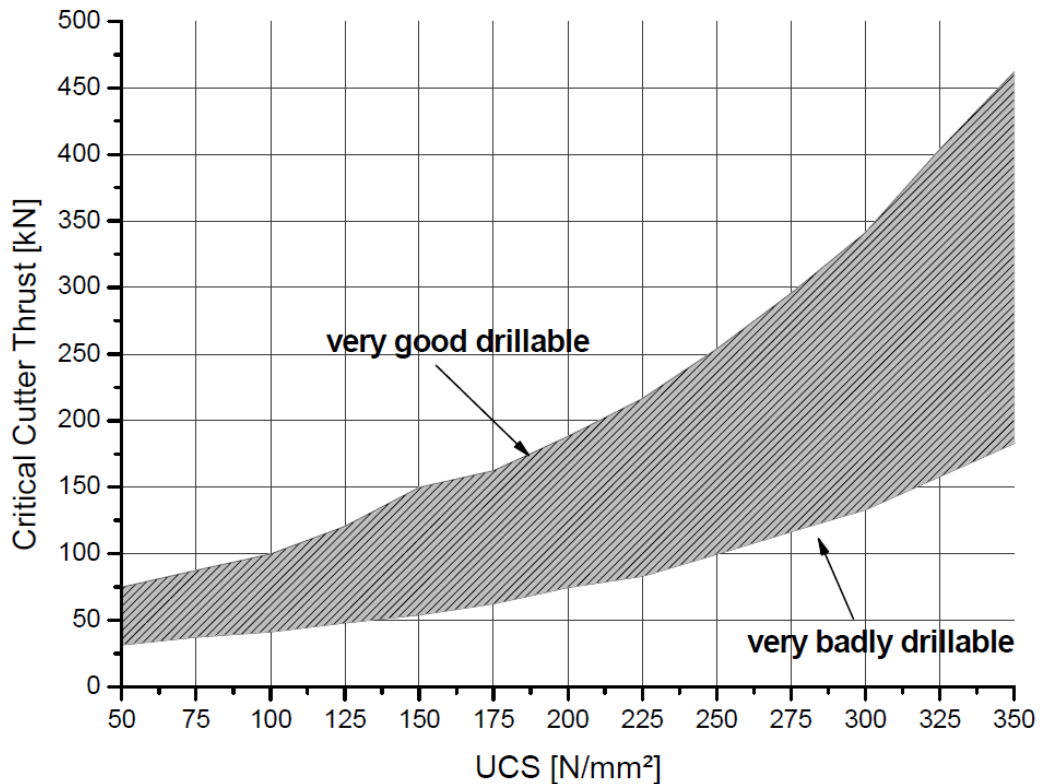

Figure 6: Phases of chip formation (modified after [4])

Gehring also looked at the induced energy and discovered that the induced force should not fall below a certain value to get a clean chip formation. This force is called critical cutter thrust. Diagram 1 shows the critical cutter thrust by the uniaxial compressive strength.



**Diagram 1: Zone of critical cutter thrust for a 17-inch disc cutter (modified after [4])**

To develop the basic equation for the penetration prediction Gehring used data from literature as well as data from projects. Good results could be achieved, after a comparison of various sources, for a uniaxial compressive strength from 100 to 250 N/mm<sup>2</sup>.

$$p = a \cdot \sigma_d^{-b} \quad (12)$$

p ...penetration [mm]

$\sigma_d$  ...uniaxial compressive strength [kN/mm<sup>2</sup>]

a ...factor [-]

b ...factor [-]



Source	a	b
NTH	3530	1.29
Graham	778	0.99
Farmer	729	0.98
Hughes	2295	1.19
Sanyo	846	1.00

**Table 2: Factors for the base equation of Gehring (from [4])**

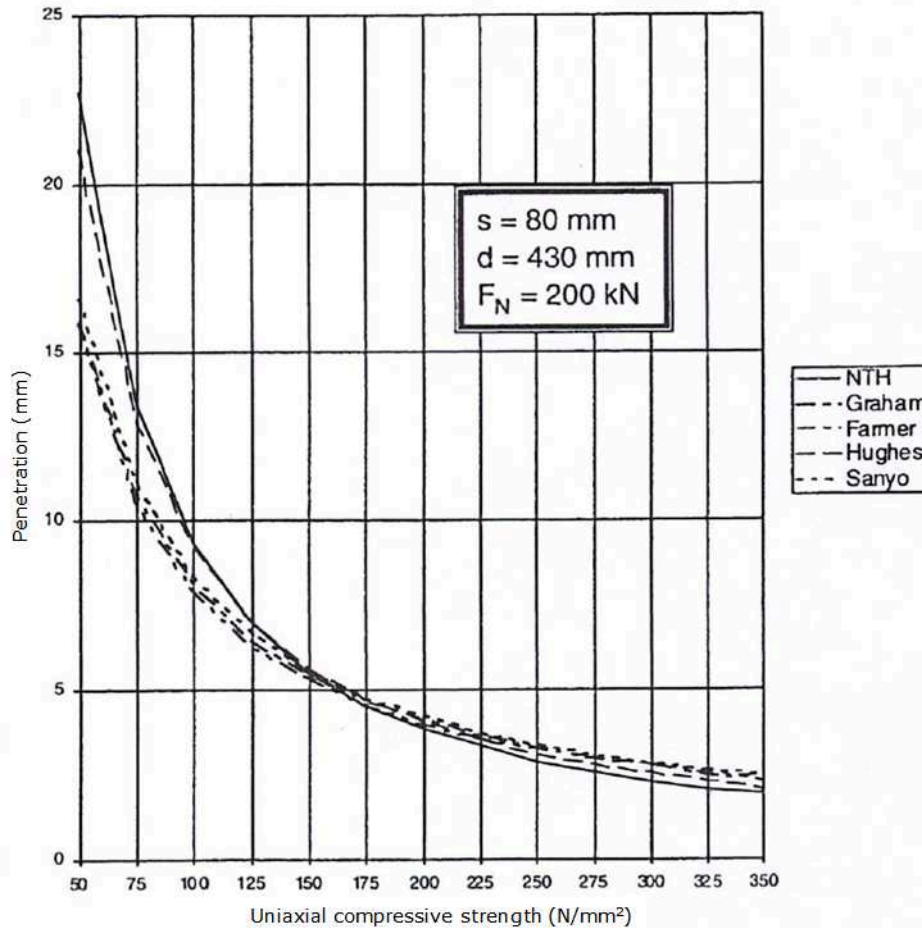

**Diagram 2: Penetration  $p_{200}$  (for  $F_N=200$  kN) as a function of the uniaxial compressive strength (from [4])**

A function for average rock parameters and an average thrust of  $F_N=200$  kN is given as follows:

$$p \approx \frac{800}{\sigma_d} \approx \frac{4 \cdot \overline{F_N}}{\sigma_d} \quad (13)$$

$F_N$  ...average thrust [kN]

Correction factors are introduced to take deviations of the average values into account.

$$p = k_1 \cdot k_2 \cdot \dots \cdot k_i \cdot \frac{\overline{F_N}}{\sigma_d} \quad (14)$$

- $k_1$  ...defined as 4 in the base function for average parameter [-]  
 $k_2$  ...correction factor for rock texture [-]  
 $k_3$  ...correction factor for increasing diameter and high overlap [-]  
 $k_4$  ...correction factor for the cutting ring diameter [-]

## **3 Methods**

This chapter describes the Linear Cutting Machine as well as its settings. It also summarizes which rock types are used and how they were prepared for the cutting tests. The testing procedure is discussed by the means of depicting the cutting program, the calibration procedure, the sampling procedure, the sieve analysis, and the aspect ratio analysis.

### **3.1 Linear Cutting Machine (LCM)**

#### **3.1.1 Machine Description**

The cutter of the Linear Cutting Machine (LCM) is mounted on a stiff reaction frame and a triaxial load cell is installed between the frame and the cutter to record the forces. To monitor the movement of the rock sample under the cutter a variable displacement transducer (LVDT) is also installed on the machine. To ensure the required confinement for the tests, the rock samples are set in a steel box and cast in concrete. Figure 7 and Figure 8 (A) show the pictures and the schematic layouts of the LCM. [5]

To move the rock sample through the cutter a servo controlled hydraulic actuator pushes the box forward. The normal, drag and side forces acting on the cutter are recorded by the triaxial load cell during the test. The forces acting on the cutter are shown in Figure 8 (B).

The surface of the rock samples is conditioned with several cutting passes before the data measurement begins. These conditioning passes are made to simulate the individual cutter of a TBM, which mostly cuts previously damaged rock surfaces. The nomenclature used for the tests is explained in Figure 8 (C).

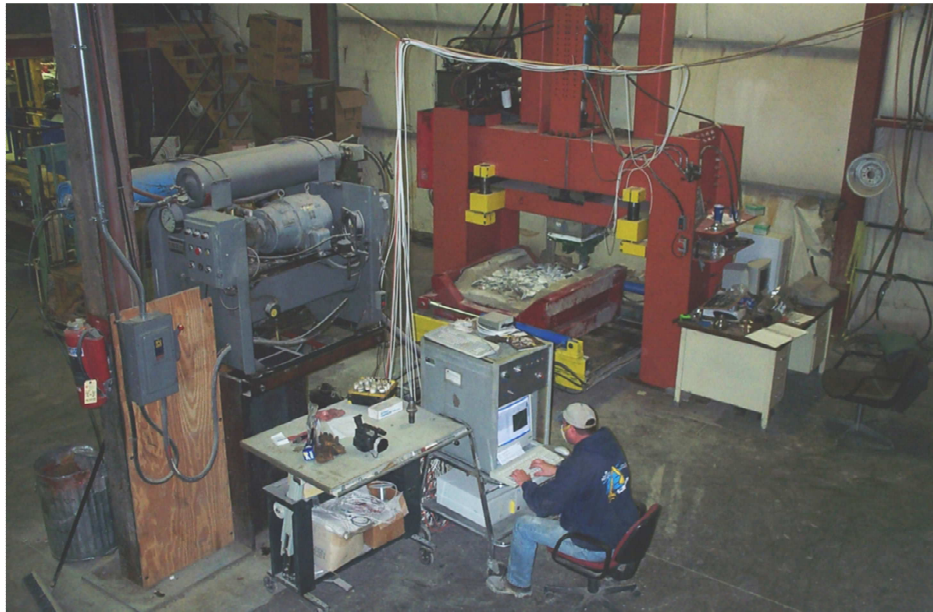

**Figure 7: LCM at the EMI, Colorado School of Mines**

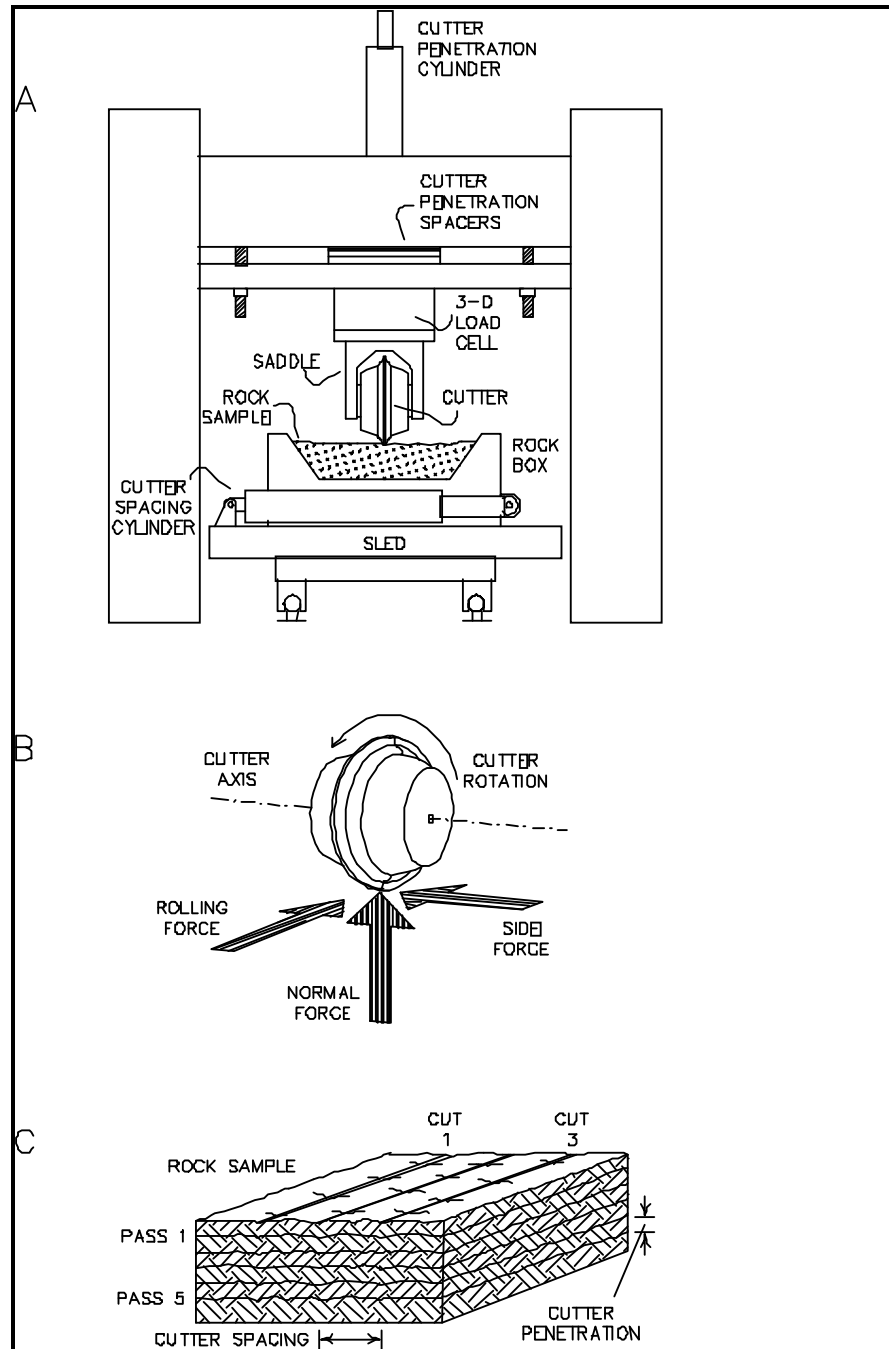

**Figure 8: (A) LCM layout, (B) three dimensional forces acting on a conical pick cutter, (C) sample nomenclature (from [5])**

### 3.1.2 Variation of Penetration

To adjust the cutter for different penetrations, metal plates (cutter penetration spacers) with thicknesses of 0.1 inch (0.25 cm) and 1 inch (2.54 cm) can be placed in a hydraulic adjustable gap between the main machine frame and the moveable part, where the triaxial load cell and the cutter are mounted on. The plates keep the gap at its required spacing during the cutting tests. Figure 9 shows a picture of the cutter penetration

spacers placed in the gap. The maximum overall penetration, that can be achieved that way, is 5.6 inch (14.2 cm).



**Figure 9: Cutter penetration spacers in place**

### **3.1.3 Variation of Spacing**

To vary the spacing of the cuts, the metal box with the rock samples can be moved left and right on the sled with the hydraulic cutter spacing cylinders. Each time a new rock box is placed on the sled a metal clip is fixed on the right side of the box and marks are made on the sled to locate where the cutter is currently over the rock. The spacing of the marks defines the spacing of the cuts on the rock sample. To move from one cut to the adjacent cut, the sample box is moved until the clip reaches the next spacing mark.

### **3.1.4 Variation of Disc Diameter**

The cutter is mounted on the saddle and secured with wedges that are screwed in between the cutter and the saddle. Different disc sizes and different saddles can be used with the machine. The disc size used for the tests is 17 inches.

### **3.1.5 Variation of Cutting Velocity**

The sled can be moved forward and back underneath the disc cutter by the servo controlled hydraulic actuator. The velocity can be chosen at the central remote unit that controls the hydraulic actuator. At the central remote unit, one velocity out of four can be chosen. The sled can also be retracted and jogged back and forward. For the tests, a velocity of 40 in/s (1 m/s) was used.

### 3.1.6 Specific Energy

The actual force requirements on the cutter are recorded during the linear cutting tests. The specific energy requirement is calculated based on the drag forces related to volume of the material cut. Its unit is hp-hr/yd<sup>3</sup> (kWh/m<sup>3</sup>).

### 3.2 Rock Samples

Cubes with the dimensions of 30x30x30 cm were cut from three different rock types, each with a different foliation direction (see Figure 10). Three cubes of each foliation direction (depending on the rock type; parallel, perpendicular, massive and oblique to the cutting direction, see Table 3) were taken. In this case massive means that the rock is folded and has no preferred foliation direction.



Figure 10: Cut rock cubes

Rock Type	Foliation Directions
calcareous mica schist (Kalkglimmerschiefer) KGS	<ul style="list-style-type: none"> <li>• parallel</li> <li>• perpendicular</li> <li>• oblique</li> <li>• massive</li> </ul>
augen gneiss (Augengneis) AG	<ul style="list-style-type: none"> <li>• parallel</li> <li>• perpendicular</li> <li>• oblique</li> </ul>
schistose gneiss (Schiefergneis) SG	<ul style="list-style-type: none"> <li>• oblique</li> </ul>

Table 3: Rock types and the orientations of their foliation to the cutting direction

### 3.2.1 Calcareous Mica Schist

The calcareous mica schist was tested for various rock parameters at the University of Leoben and Table 4 shows the average values and the standard deviation for most parameters.

Rock Parameter	Unit	Average Value	Standard Deviation
Uniaxial Compressive Strength	[MPa]	83.2	5.2
Young's Modulus	[GPa]	54.5	2.2
Deformation Modulus	[GPa]	41.0	4.7
Poisson's Ratio	[-]	0.21	0.01
Brazilian Tensile Strength	[MPa]	8.7	1.4
Friction Angle	[°]	33	-
Cohesion	[MPa]	24	-
Hoek Brown Constant	[-]	6	-

**Table 4: Average values and standard deviation of rock parameters of calcareous mica schist (modified after [6])**

Figure 11 shows a picture of the rock cubes of calcareous mica schist with perpendicular, parallel, oblique and massive foliation direction.



**Figure 11: Rock cubes of calcareous mica schist with perpendicular, parallel, oblique and massive foliation direction**



### 3.2.2 Augen Gneiss

The augen gneiss was tested for various rock parameters at the University of Leoben and Table 5 shows the average values and the standard deviation for most parameters.

Rock Parameter	Unit	Average Value	Standard Deviation
Uniaxial Compressive Strength	[MPa]	228.4	21.0
Young's Modulus	[GPa]	36.7	1.8
Deformation Modulus	[GPa]	31.1	1.6
Poisson's Ratio	[-]	0.11	0.02
Brazilian Tensile Strength	[MPa]	12.4	3.0
Friction Angle	[°]	54	-
Cohesion	[MPa]	44	-
Hoek Brown Constant	[-]	21	-

**Table 5: Average values and standard deviation of rock parameter of augen gneiss (modified after [6])**

Figure 12 shows a picture of the rock cubes of augen gneiss with perpendicular, parallel and oblique foliation direction.



**Figure 12: Rock cubes of augen gneiss with perpendicular, parallel and oblique foliation direction**

### 3.2.3 Schistose Gneiss

The schistose gneiss was tested for various rock parameters by the ÖBB and Table 6 shows the average values and the standard deviation for a few of those parameters.

Rock Parameter	Unit	Average Value	Standard Deviation
Uniaxial Compressive Strength	[MPa]	81.4	44.3
Young's Modulus	[GPa]	59.5	21.3
Deformation Modulus	[GPa]	54.1	21.1
Poisson's Ratio	[-]	0.15	0.05
Brazilian Tensile Strength	[MPa]	11.0	9.0
Friction Angle	[°]	34	-
Cohesion	[MPa]	22	-
Hoek Brown Constant	[-]	9	-

**Table 6: Average values and standard deviation of rock parameter of schistose gneiss (modified after [6])**

Figure 13 shows a picture of the rock cube of schistose gneiss with oblique foliation direction.

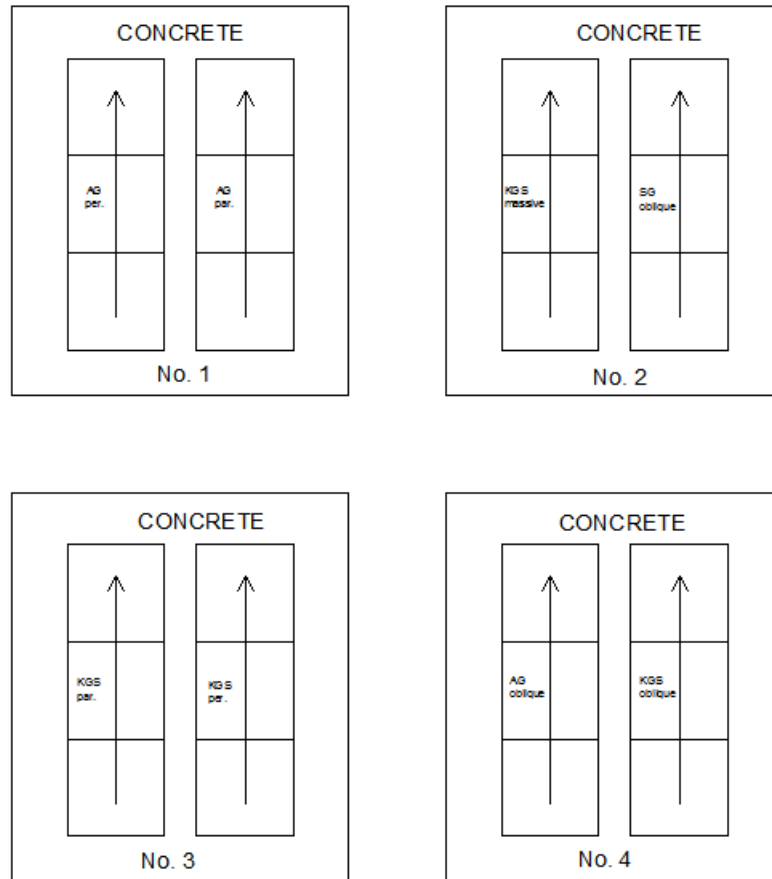

**Figure 13: Rock cube of schistose gneiss with oblique foliation direction**

### 3.3 Testing Procedure

#### 3.3.1 Box Preparation

The rock samples are set into four heavy metal boxes in two rows of three rock cubes (shown in Figure 14 and Figure 15). Each row consists of three cubes from one rock type with a specific foliation direction. The box is then filled with concrete and the concrete surface is smoothed and flattened with a trowel (see Figure 16). After the concrete has cured, the boxes are turned over so that the rock cube surfaces are on top. The box is placed on the LCM sled and secured by the cutter spacing cylinders.



**Figure 14: Four boxes with rock cubes**



**Figure 15: Rock cubes placed in the metal box lined with plastic sheeting**



**Figure 16: Metal boxes filled with concrete**

### 3.3.2 Cutting Program

For the first tested box (Box No. 2), a different cutting program was used than for the other three boxes (see Table 7 to Table 10). Every time the box, the spacing or the penetration changed a new series (MULxx) was started. Four different spacing-penetration combinations were used for the measurement cuts. Before the measurement passes for each combination of spacing and penetration started, two conditioning cuts were carried out with the spacing of the following measurement passes and a penetration of always 0.2 inch (5.1 mm). Data and sieve samples were only collected for cuts in measurement passes to eliminate influences of spacing changes.

Series	Passes	Penetration		Total Penetration		Cutter Spacing	Note
		inch	mm	inch	mm		
-	-	inch	mm	inch	mm	mm	-
-	1	0.1	2.5	0.1	3	60	Disc lowering
MUL01	2	0.2	5.1	0.5	13	60	Conditioning
	4	0.2	5.1	1.3	33	60	Measurement
MUL02	4	0.3	7.6	2.5	64	60	Measurement
MUL03	2	0.2	5.1	2.9	74	80	Conditioning
MUL04	5	0.3	7.6	4.4	112	80	Measurement
MUL05	2	0.2	5.1	4.8	122	100	Conditioning
MUL06	2	0.3	7.6	5.4	137	100	Measurement
<b>TOTAL</b>				<b>5.4</b>	<b>137</b>		

**Table 7: Cutting program for Block 2**

Series	Passes	Penetration		Total Penetration		Cutter Spacing	Notes
		inch	mm	inch	mm		
-	-	inch	mm	inch	mm	mm	-
MUL07	2	0.2	5.1	0.4	10	60	Conditioning
	4	0.2	5.1	1.2	30	60	Measurement
MUL08	4	0.3	7.6	2.4	60	60	Measurement
MUL09	2	0.2	5.1	2.8	71	80	Conditioning
MUL10	4	0.3	7.6	4.0	102	80	Measurement
MUL11	2	0.2	5.1	4.4	112	100	Conditioning
MUL12	4	0.3	7.6	5.6	142	100	Measurement
<b>TOTAL</b>				<b>5.6</b>	<b>142</b>		

Table 8: Cutting program for Block 1

Series	Passes	Penetration		Total Penetration		Cutter Spacing	Notes
		inch	mm	inch	mm		
-	-	inch	mm	inch	mm	mm	-
MUL13	2	0.2	5.1	0.4	10	60	Conditioning
	4	0.2	5.1	1.2	30	60	Measurement
MUL14	4	0.3	7.6	2.4	61	60	Measurement
MUL15	2	0.2	5.1	2.8	71	80	Conditioning
MUL16	4	0.3	7.6	4.0	102	80	Measurement
MUL17	2	0.2	5.1	4.4	112	100	Conditioning
MUL18	4	0.3	7.6	5.6	142	100	Measurement
<b>TOTAL</b>				<b>5.6</b>	<b>142</b>		

Table 9: Cutting program for Block 3

Series	Passes	Penetration		Total Penetration		Cutter Spacing	Notes
		inch	mm	inch	mm		
-	-	inch	mm	inch	mm	mm	-
MUL19	2	0.2	5.08	0.4	10	60	Conditioning
	4	0.2	5.08	1.2	30	60	Measurement
MUL20	4	0.3	7.62	2.4	61	60	Measurement
MUL21	2	0.2	5.08	2.8	71	80	Conditioning
MUL22	4	0.3	7.62	4.0	102	80	Measurement
MUL23	2	0.2	5.08	4.4	112	100	Conditioning
MUL24	4	0.3	7.62	5.6	142	100	Measurement
<b>TOTAL</b>				<b>5.60</b>	<b>142</b>		

Table 10: Cutting program for Block 4

Different cut layouts for Block 1 with all spacings are shown in Figure 17 to Figure 19. The cuts are numbered from the right to the left and cut zero and the cut xC (cut 5C for 60 mm spacing and cut 4C for 80 and 100 mm spacing) are cuts in concrete.

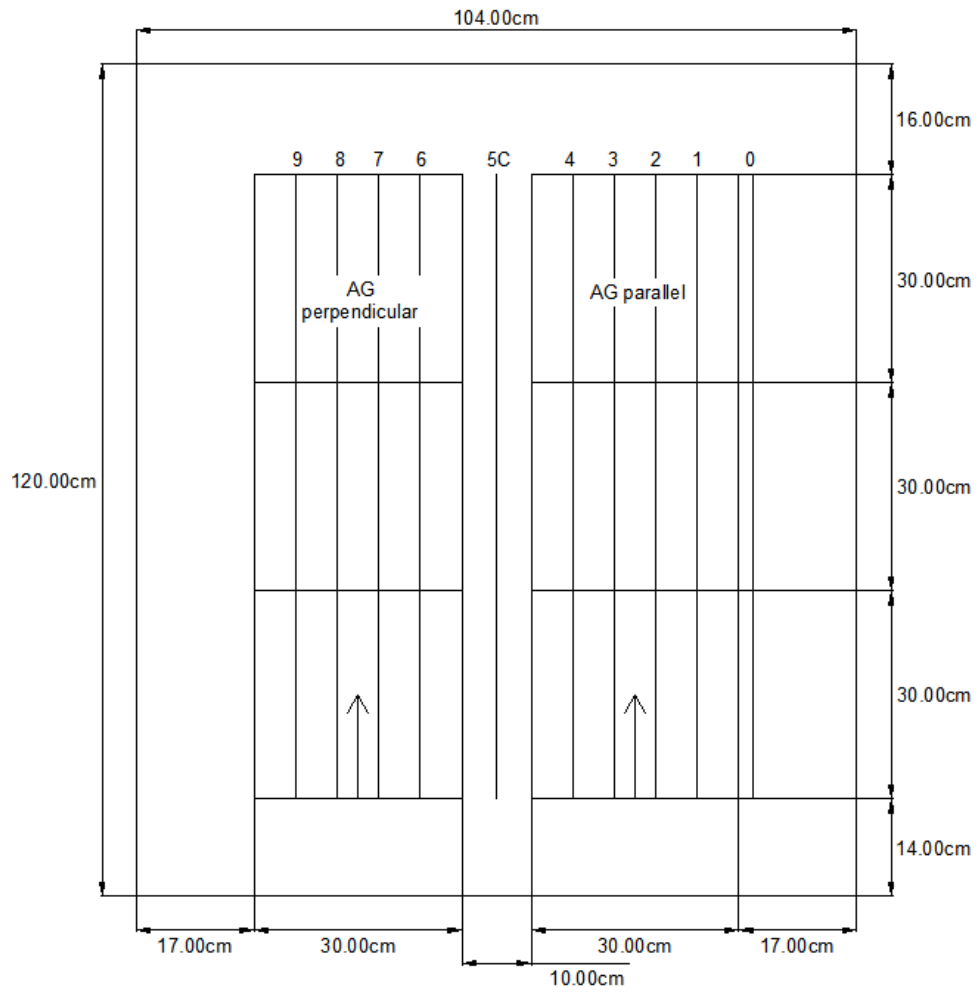

**Figure 17: Block 1 with 60 mm spacing**

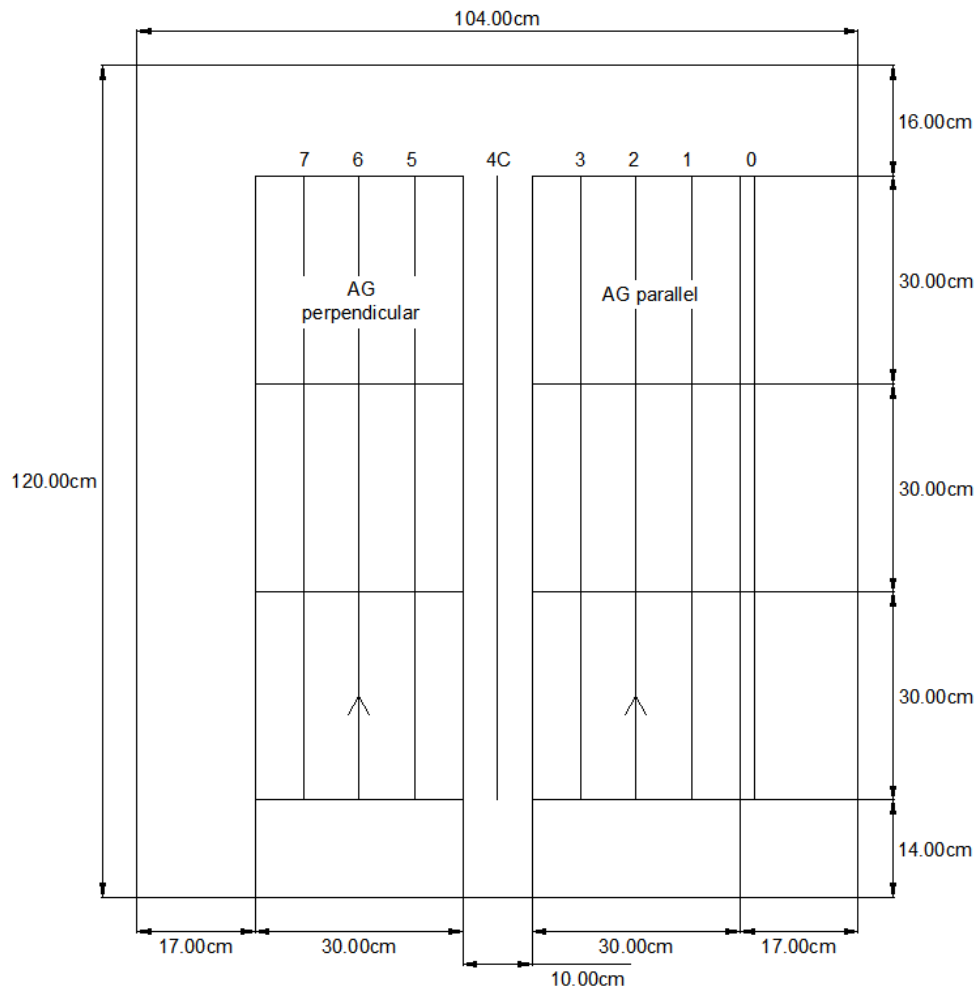

**Figure 18: Block 1 with 80 mm spacing**

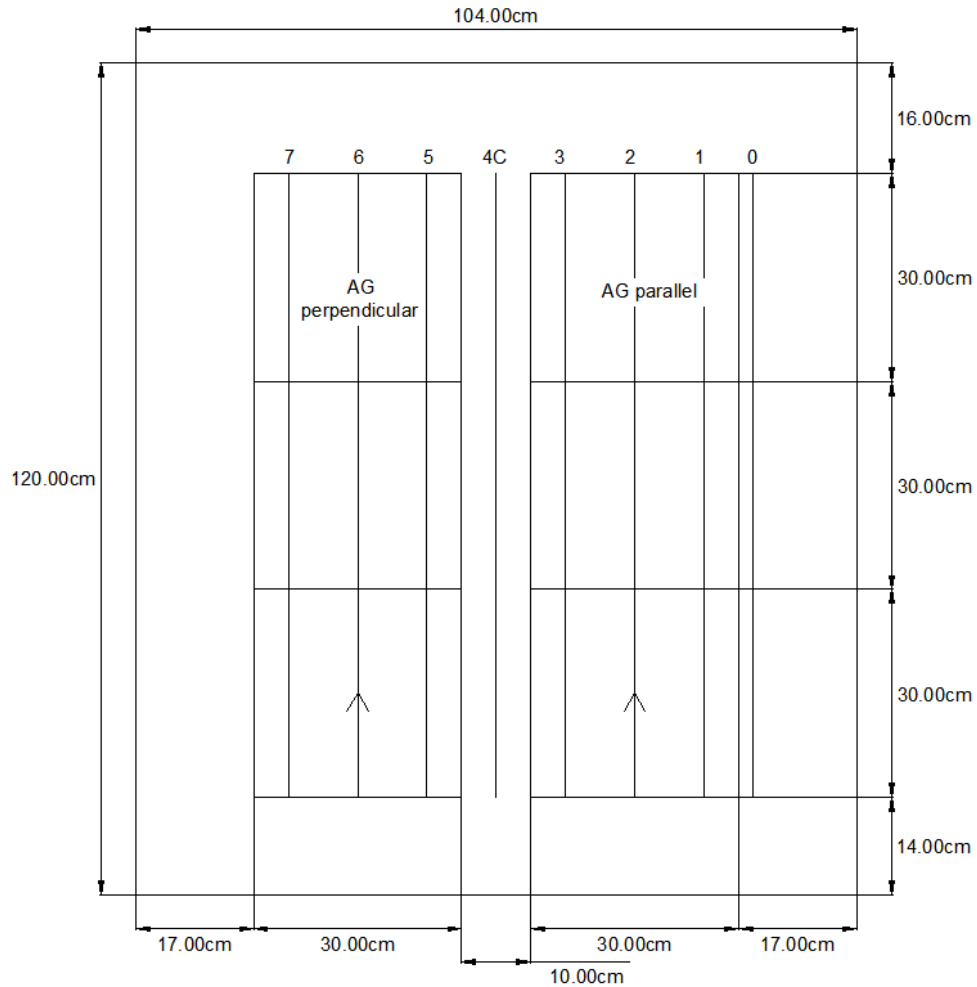

**Figure 19: Block 1 with 100 mm spacing**

### 3.3.3 LCM Calibration

The LCM was calibrated for the 17-inch disc cutter using a hydraulic jack positioned under the disc cutter at an angle of  $9^\circ$  according to the layout shown in Figure 20. The pressure on the disc was increased in 1000 psi increments from 0 to 5000 psi by the hydraulic jack and the forces on the disc cutter were recorded. The recorded data was used to calibrate the LCM for the following cutting tests.



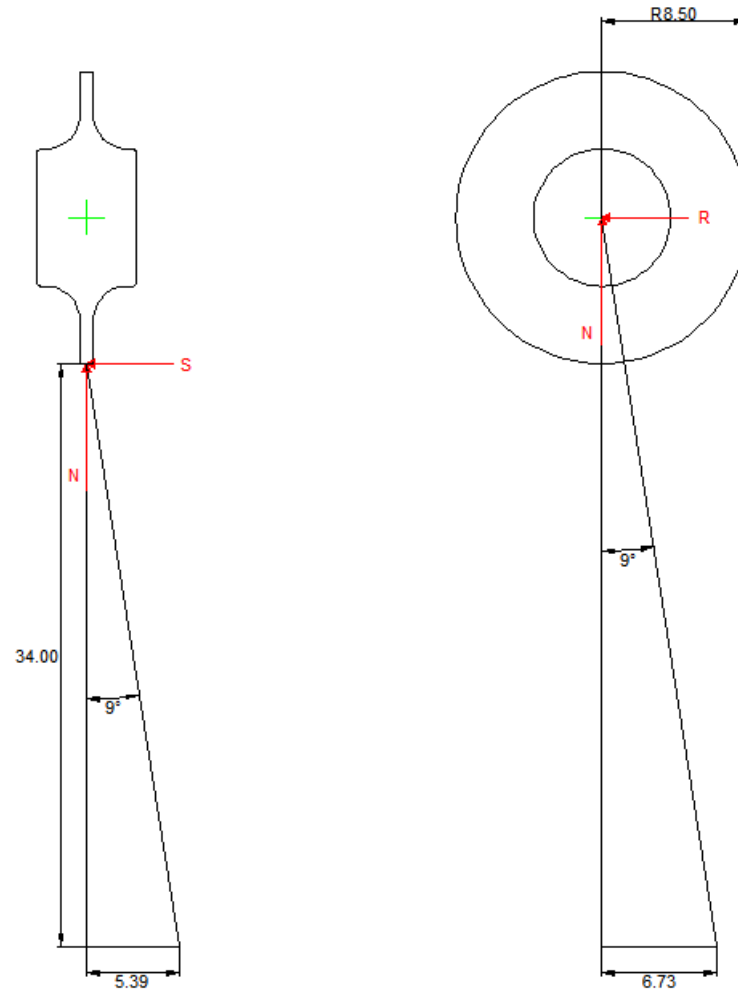
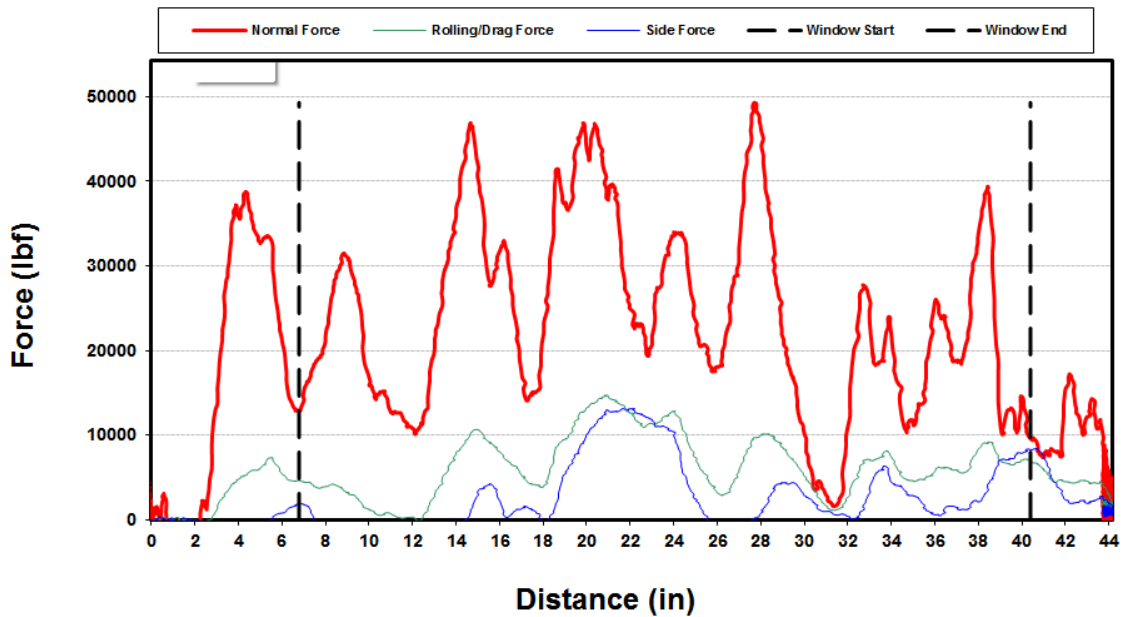

Figure 20: Layout of the calibration configuration (in inch)

### 3.4 Forces

During each cut on the rock of a measurement pass, the triaxial load cell measured the normal, drag and side forces acting on the cutter (shown in Diagram 3). To get comparable results for all rock types the force values have been averaged over all center cuts of one spacing-penetration combination for each rock row. The cuts on the edges have not been considered to leave out possible influences from the edge.



**Diagram 3: Normal, drag and side force of a cut on calcareous mica schist with oblique foliation direction**

### 3.5 Sampling

Samples for the sieve analysis and the aspect ratios were taken from the center cuts of each rock row for each measurement pass. Two squares were laid over the center cuts leaving out about 5 cm at the start and end of the rows to avoid the influence of the edges (see Figure 21). The material from the area between the squares was collected. Coarser grains were cleaned off the rock with a brush and finer grains with a handheld vacuum cleaner. The samples were packed individually in Ziploc bags and labeled according to their rock type, pass number, cut number, spacing and penetration.



**Figure 21: Area between squares for schistose gneiss, series MUL02, pass 08, spacing 60 mm and penetration 7.6 mm**

### 3.6 Sieve Analysis

Each taken sample has been sieved individually on a Roto-tap. A Roto-tap is a sieve stack, which shakes the sieve screens in the radial and vertical directions. The samples were processed through a series of eight sieves using the Roto-tap for five minutes. The sieve sizes were 88.9, 45, 32, 16, 9.51, 4, 2, 1.19 mm with a catch pan on the bottom. To compare the different influential factors all grain distributions of all measurement passes for one series have been averaged. Comparisons were made between all spacing-penetration combinations of one rock type with one foliation direction and between all foliation directions of one rock type with one specific spacing-penetration combination.

### 3.7 Aspect Ratio Analysis

For the aspect ratio analysis, a maximum of 20 grains of each sieve size for each sample were measured for its length, thickness and mass using a caliper and a laboratory scale. The length to thickness ratio of each grain was determined and the mass percentage of all grains with a ratio over three of each sieve size was calculated. Averages of the mass percentages over all sieve sizes for a sample and for all passes of one series were also calculated.

## 4 Results

The results of the cutting tests, the sieve analysis and the aspect ratio analysis are summarized and discussed.

### 4.1 Cutting Forces

The average and maximum forces are listed in Table 11 through Table 13 ordered by foliation direction, spacing and penetration. The average normal forces on the disc cutter are plotted by penetration for each rock type and spacing in Diagram 4 to Diagram 6.

#### 4.1.1 Calcareous Mica Schist

Table 11 and Diagram 4 indicate that the average normal force increases with increasing penetration whereas it does not constantly increase with increasing spacing.

Foliation Direction	Spacing (mm)	Pene- tration (mm)	Average Forces			Maximum Forces		
			Normal (kN)	Rolling (kN)	Side (kN)	Normal (kN)	Rolling (kN)	Side (kN)
massive	60	5.1	92.33	23.08	-1.45	233.55	48.41	20.28
	60	7.6	152.91	30.07	-5.57	339.47	54.11	26.07
	80	7.6	140.77	32.99	2.51	327.09	63.02	41.72
	100	7.6	155.81	32.96	0.59	394.55	67.74	35.34
perpendicular	60	5.1	119.83	26.05	-0.80	294.57	57.85	14.20
	60	7.6	192.36	34.03	-7.79	387.55	65.87	19.73
	80	7.6	182.94	34.51	-4.12	395.16	69.86	27.53
	100	7.6	199.41	34.01	-5.62	470.56	74.10	41.90
parallel	60	5.1	61.15	16.86	3.89	208.01	46.93	24.61
	60	7.6	129.51	24.56	-2.48	317.28	51.02	33.55
	80	7.6	171.64	35.86	4.19	333.40	67.31	54.49
	100	7.6	123.75	27.01	6.35	325.20	63.21	59.20
oblique	60	5.1	65.22	18.29	3.86	188.69	41.02	25.32
	60	7.6	107.82	24.93	3.31	302.16	56.17	34.57
	80	7.6	130.09	27.93	2.61	351.16	63.57	35.90
	100	7.6	121.03	30.74	10.02	308.19	63.39	49.28

**Table 11: Average and maximum forces ordered by foliation direction, spacing and penetration for calcareous mica schist**

Diagram 4 displays the change of the average normal forces of calcareous mica schist depending on spacing and penetration. There is an apparent increase of the force for the increase of penetration whereas the influence

of the increase of spacing only is considerably high (change of more than 40 kN from on spacing to the next) for calcareous mica schist with parallel foliation direction. The average normal force for the spacing-penetration combination of 60-5.1 mm is the lowest for all foliation directions of calcareous mica schist. The forces of massive and perpendicular foliation direction for the penetration of 7.6 mm change just slightly (about 10 kN change).

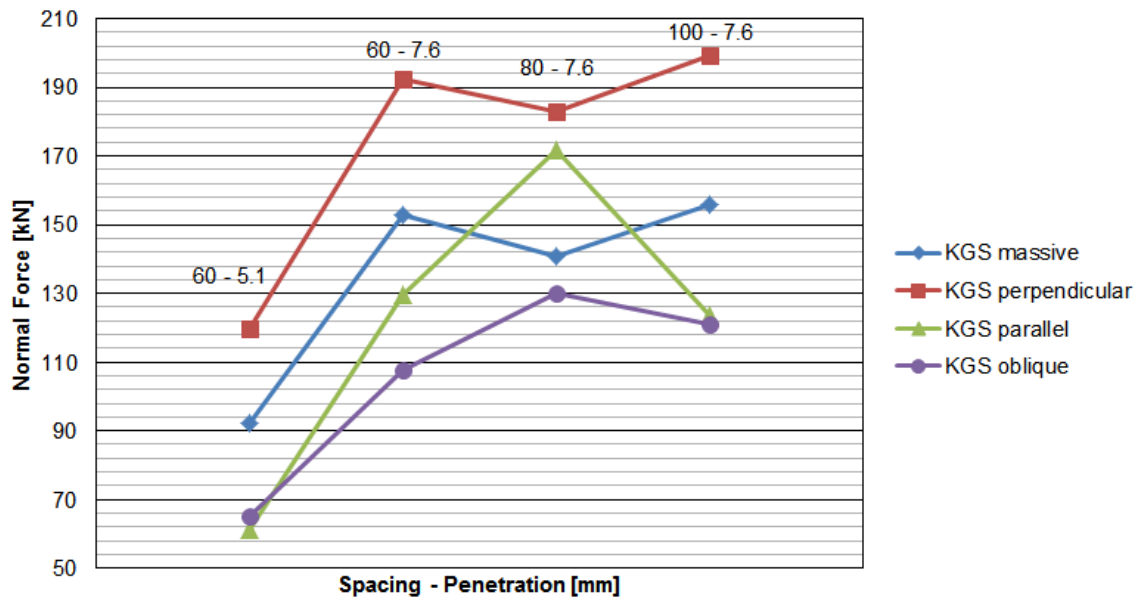

**Diagram 4: Average normal forces of calcareous mica schist**

#### 4.1.2 Augen Gneiss

Table 12 and Diagram 5 show that the average normal force increases with increasing penetration whereas it does not constantly increase with increasing spacing.

Foliation Direction	Spacing (mm)	Pene- tration (mm)	Average Forces			Maximum Forces		
			Normal (kN)	Rolling (kN)	Side (kN)	Normal (kN)	Rolling (kN)	Side (kN)
perpendicular	60	5.1	112.47	30.78	5.37	282.31	68.19	31.67
	60	7.6	178.37	32.13	-5.81	400.29	75.64	29.77
	80	7.6	203.79	38.80	-3.43	447.35	83.89	30.43
	100	7.6	196.57	45.53	12.02	436.16	84.92	58.65
parallel	60	5.1	89.64	21.11	0.13	313.55	60.39	16.60
	60	7.6	136.70	25.50	-5.53	397.91	66.81	22.21
	80	7.6	214.04	36.04	-9.94	447.34	72.82	26.79
	100	7.6	211.96	39.42	-5.21	478.69	76.54	27.18
oblique	60	5.1	72.79	19.80	4.38	219.84	52.75	31.07
	60	7.6	134.26	29.89	3.35	326.53	66.91	43.54
	80	7.6	161.01	34.16	5.02	350.82	75.87	48.55
	100	7.6	173.14	39.85	10.32	397.44	82.00	56.81

**Table 12: Average and maximum forces ordered by foliation direction, spacing and penetration for augen gneiss**

Diagram 5 shows the average normal force of augen gneiss for all spacings and penetrations. The force increases with increasing penetration and most of the time also with increasing spacing, although the forces of perpendicular and parallel foliation direction decreases from 80 mm to 100 mm spacing slightly (under 10 kN).

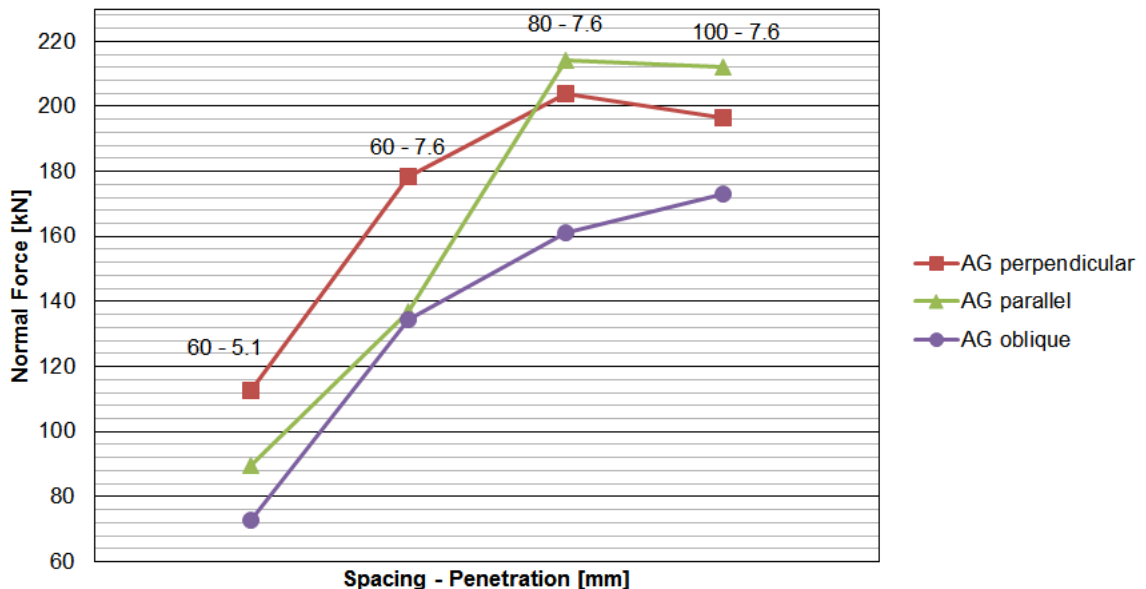

**Diagram 5: Average normal forces of augen gneiss**

### 4.1.3 Schistose Gneiss

Table 13 and Diagram 6 reveal that the average normal force increases with increasing penetration whereas it does not increase with increasing spacing.

Foliation Direction	Spacing	Penetration	Average Forces			Maximum Forces		
			Normal	Rolling	Side	Normal	Rolling	Side
	(mm)	(mm)	(kN)	(kN)	(kN)	(kN)	(kN)	(kN)
oblique	60	5.1	109.35	26.25	-1.66	264.77	50.73	21.54
	60	7.6	131.81	27.15	-2.66	317.88	59.96	27.57
	80	7.6	210.37	47.28	5.49	424.46	77.39	46.18
	100	7.6	192.29	49.13	14.32	369.96	74.98	51.06

**Table 13: Average and maximum forces ordered by spacing and penetration for schistose gneiss**

Diagram 6 indicates the average normal forces of schistose gneiss for all spacing-penetration combinations. The force increases with increasing penetration and also with increasing spacing from 60 to 80 mm, but decreases from 80 to 100 mm spacing.

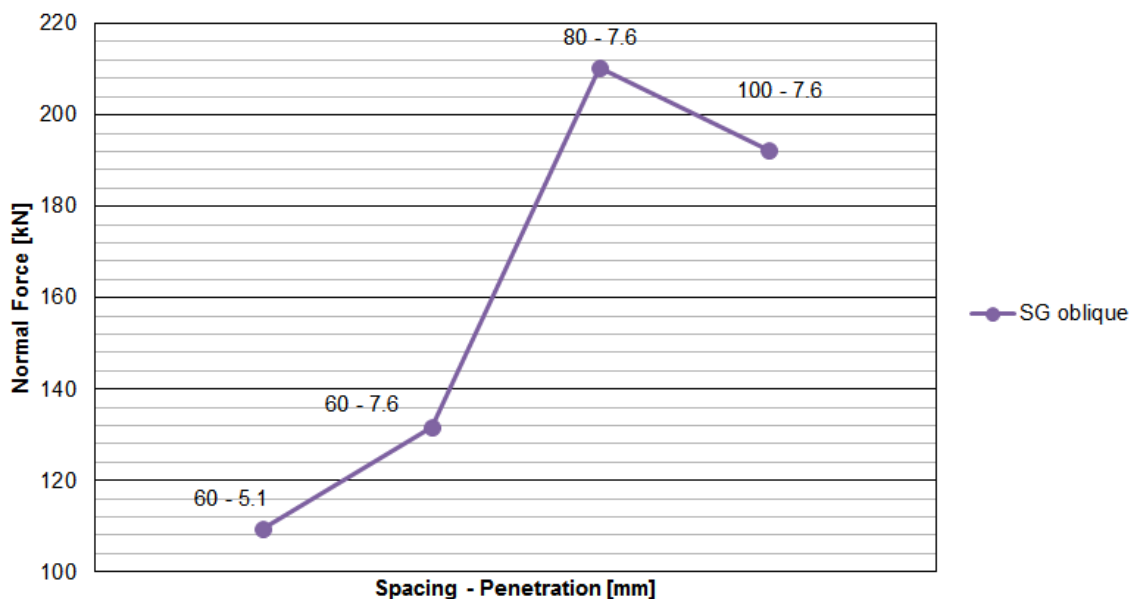

**Diagram 6: Average normal forces of schistose gneiss**

## 4.2 Sieve Analysis

Each of the following grading curves is an average curve calculated from all grading curves of one series. The following diagrams (Diagram 11 to Diagram 18) show a comparison of all rock types with the same foliation direction for each spacing-penetration combination. The samples of

calcareous mica schist contain always more fine grains (<1.19 mm) than those of augen gneiss. The quantity of fine grains in schistose gneiss samples lies between calcareous mica schist and augen gneiss for the spacing-penetration combinations 60-7.6 mm and 100-7.6 mm and over calcareous mica schist for the spacing-penetration combinations 60-5.1 mm and 80-7.6 mm.

Diagram 7 indicates that, for a spacing of 60mm, a penetration of 5.1 mm, and oblique foliation direction, schistose gneiss has a higher content of fine grains (31 M-%) than calcareous mica schist (27 M-%) and augen gneiss has the lowest content of fine grains (18 M-%). The difference between the percentages of passing between the three rock types gets smaller for higher particle sizes.

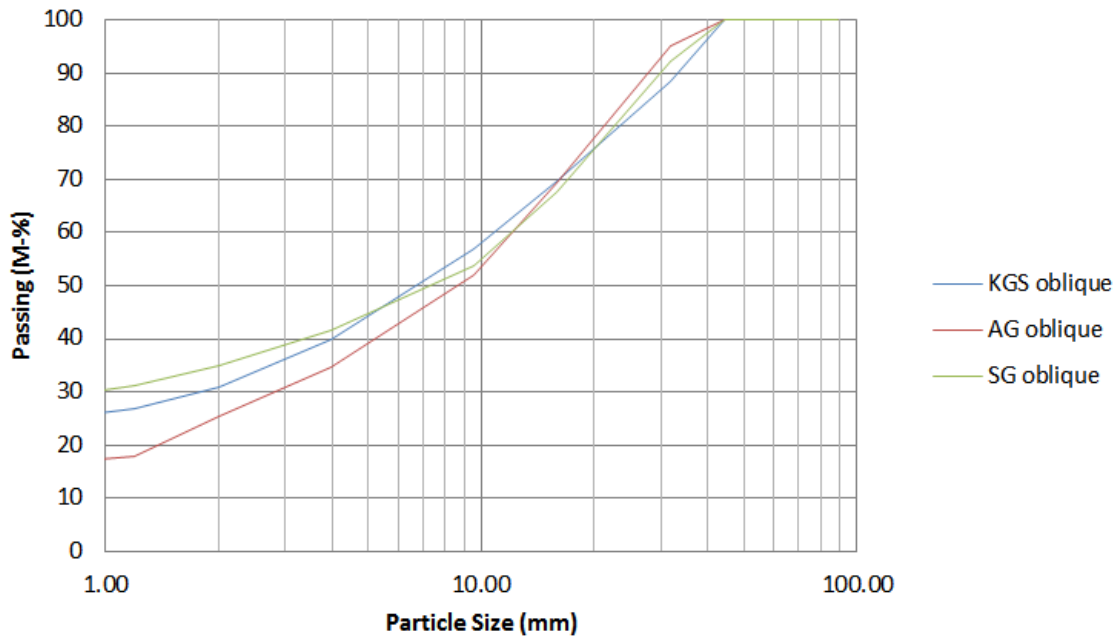

**Diagram 7: Sieve analysis of all rock types with oblique foliation direction, a spacing of 60 mm and a penetration of 5.1 mm**

Diagram 8 displays that calcareous mica schist is finer grained (25 M-%) than augen gneiss (16 M-%) for the spacing-penetration combination of 60-5.1 mm, and the foliation direction parallel. Calcareous mica schist is finer grained than augen gneiss over all particle sizes.



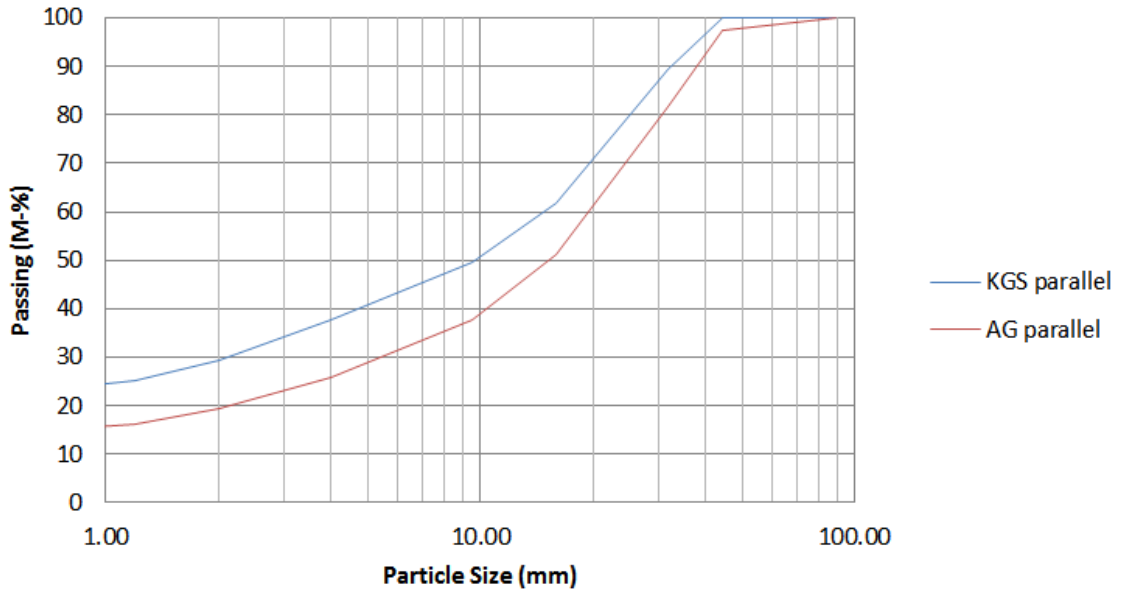

**Diagram 8: Sieve analysis of calcareous mica schist and augen gneiss with parallel foliation direction, a spacing of 60 mm and a penetration of 5.1 mm**

For a spacing of 60mm, a penetration of 5.1 mm and the foliation direction perpendicular, calcareous mica schist has with 30 M-% a higher content of fine grains than augen gneiss with 21 M-% (see Diagram 9). For these cutting parameters augen gneiss has a coarser sieve curve than calcareous mica schist.

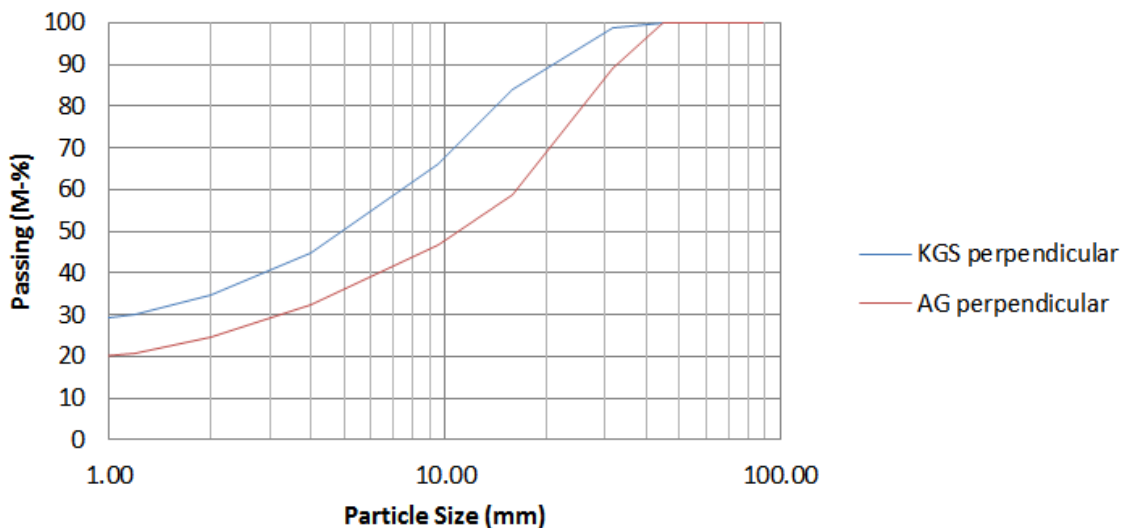

**Diagram 9: Sieve analysis of calcareous mica schist and augen gneiss with perpendicular foliation direction, a spacing of 60 mm and a penetration of 5.1 mm**

Diagram 10 shows that calcareous mica schist has the highest quantity of fine grains (27 M-%), augen gneiss the lowest (21 M-%) and schistose gneiss lies in the middle (25 M-%) for a spacing of 60 mm, a penetration of 7.6 mm and the foliation direction oblique. The grain distribution curves

differ just slightly for calcareous mica schist and augen gneiss at higher particle sizes (over 9.51 mm). The sieve curve of schistose gneiss is coarser grained than those of the other rock types.

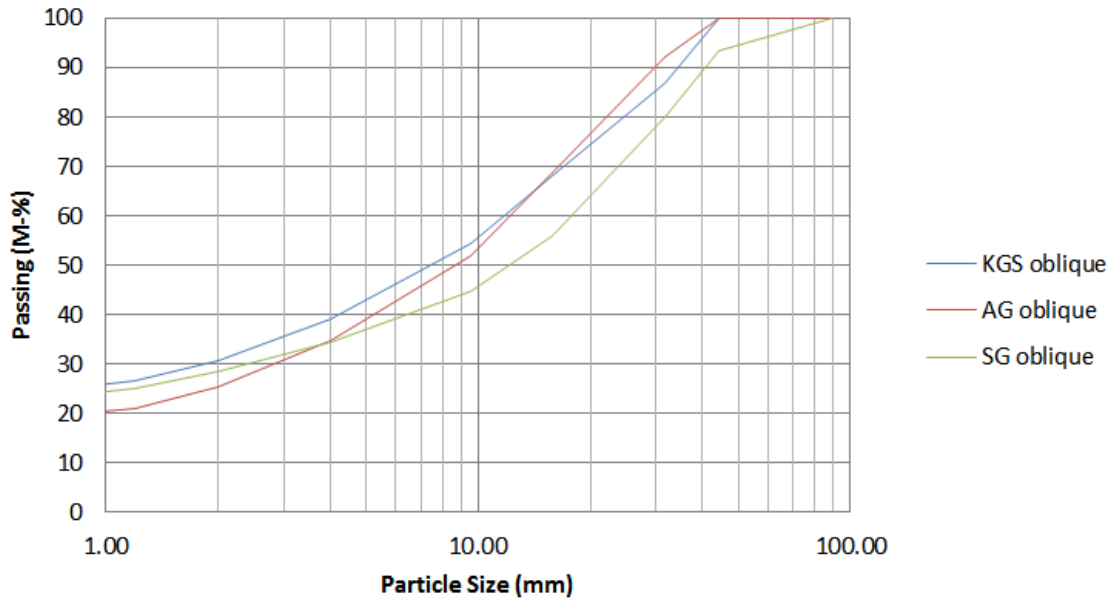

**Diagram 10: Sieve analysis of all rock types with oblique foliation direction, a spacing of 60 mm and a penetration of 7.6 mm**

For a spacing of 60 mm, a penetration of 7.6 mm and the foliation direction parallel, calcareous mica schist has with 28 M-% a higher content of fine grains than augen gneiss with 20 M-% as shown in Diagram 11. Calcareous mica schist is finer grained than augen gneiss over all particle sizes.

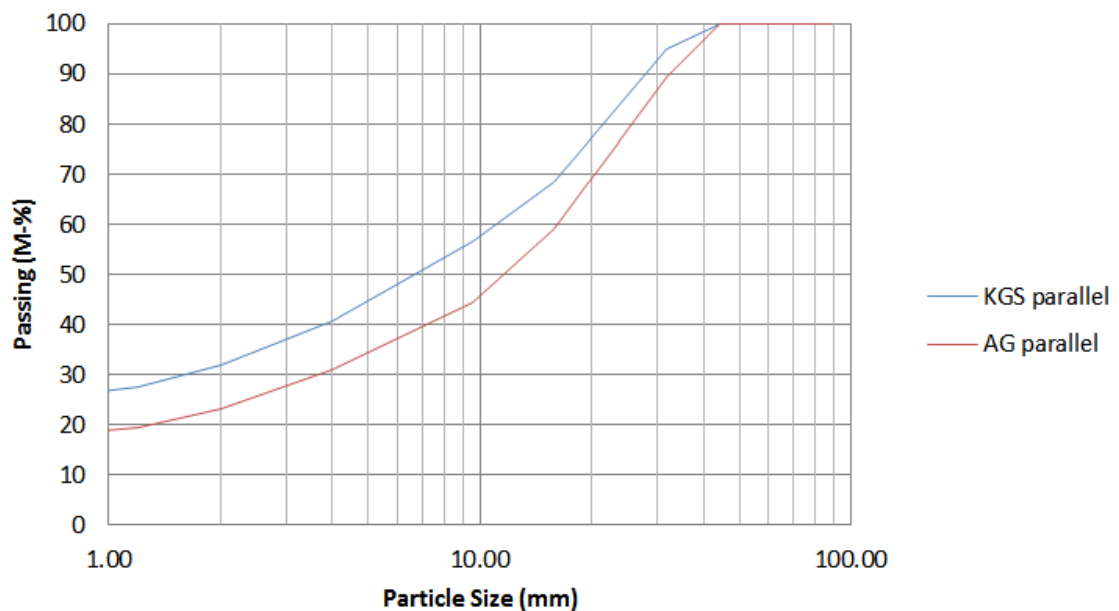

**Diagram 11: Sieve analysis of calcareous mica schist and augen gneiss with parallel foliation direction, a spacing of 60 mm and a penetration of 7.6 mm**

Diagram 12 indicates that calcareous mica schist has a higher content of fine grains (30 M-%) than augen gneiss (20 M-%) for a spacing of 60 mm, a penetration of 7.6 mm and the foliation direction perpendicular. The grain distribution curve of augen gneiss is coarser than that of calcareous mica schist.

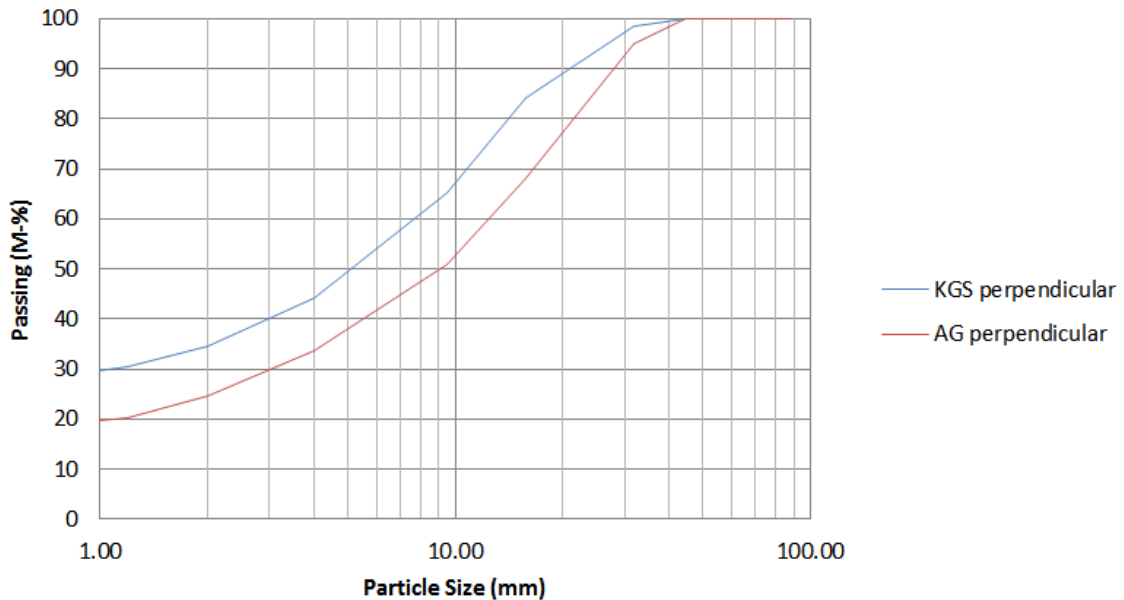

**Diagram 12: Sieve analysis of calcareous mica schist and augen gneiss with perpendicular foliation direction, a spacing of 60 mm and a penetration of 7.6 mm**

For oblique foliation direction, a spacing of 80 mm, and a penetration of 7.6 mm schistose gneiss has with 23 M-% the highest quantity of fine grains, calcareous mica schist lies with 19 M-% in the middle, and augen gneiss has with 17 M-% the lowest quantity of fine grains (shown in Diagram 13). Calcareous mica schist and schistose gneiss have a higher content of coarser grains than augen gneiss.

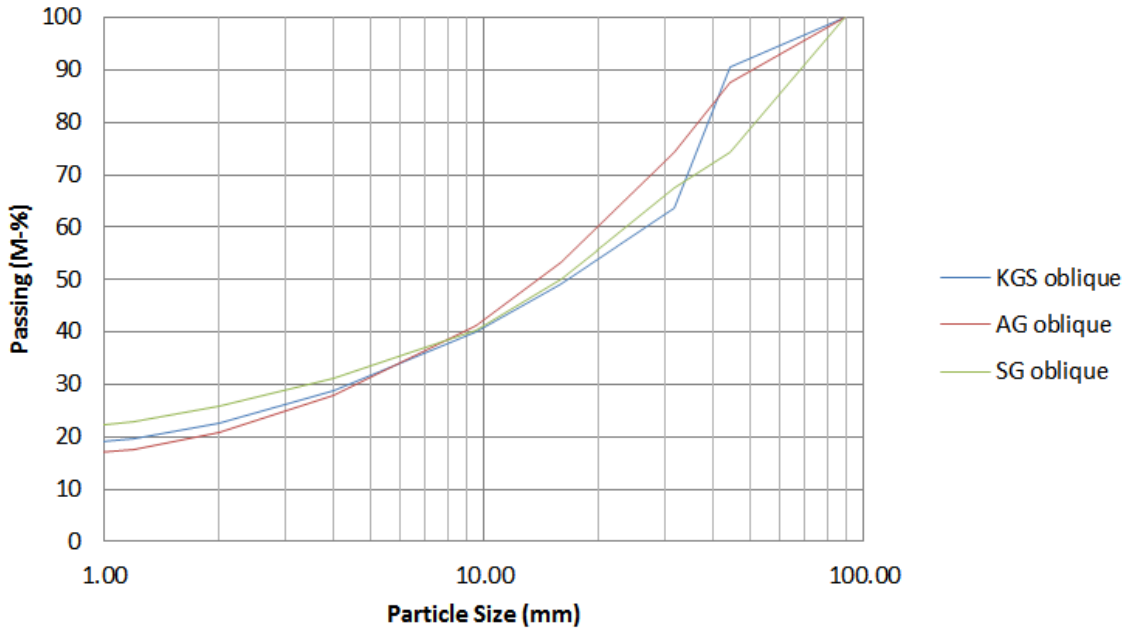

**Diagram 13: Sieve analysis of all rock types with oblique foliation direction, a spacing of 80 mm and a penetration of 7.6 mm**

Diagram 14 shows that calcareous mica schist has a higher content of fine grains (22 M-%) than augen gneiss (19 M-%) for parallel foliation direction, a spacing of 80 mm, and a penetration of 7.6 mm. The grain distribution curve of calcareous mica schist is finer grained than that of augen gneiss.

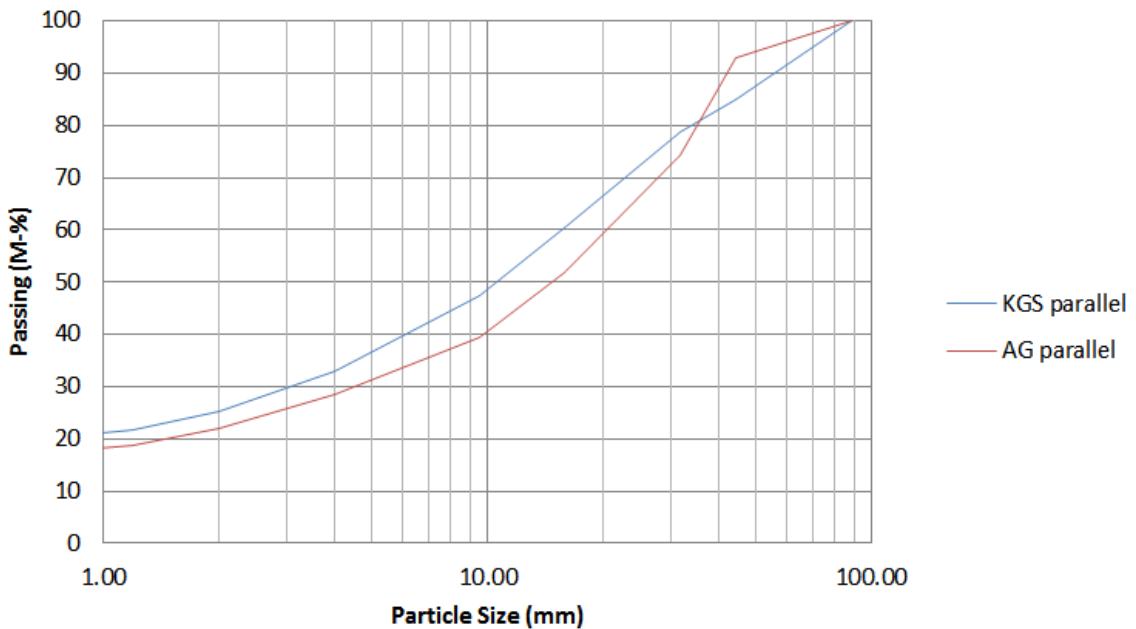

**Diagram 14: Sieve analysis of calcareous mica schist and augen gneiss with parallel foliation direction, a spacing of 80 mm and a penetration of 7.6 mm**

Diagram 15 indicates that for perpendicular foliation direction, a spacing of 80 mm, and a penetration of 7.6 mm calcareous mica schist has a higher

content of fine grains (24 M-%) than augen gneiss (17 M-%). For these cutting parameters augen gneiss has a coarser sieve curve than calcareous mica schist.

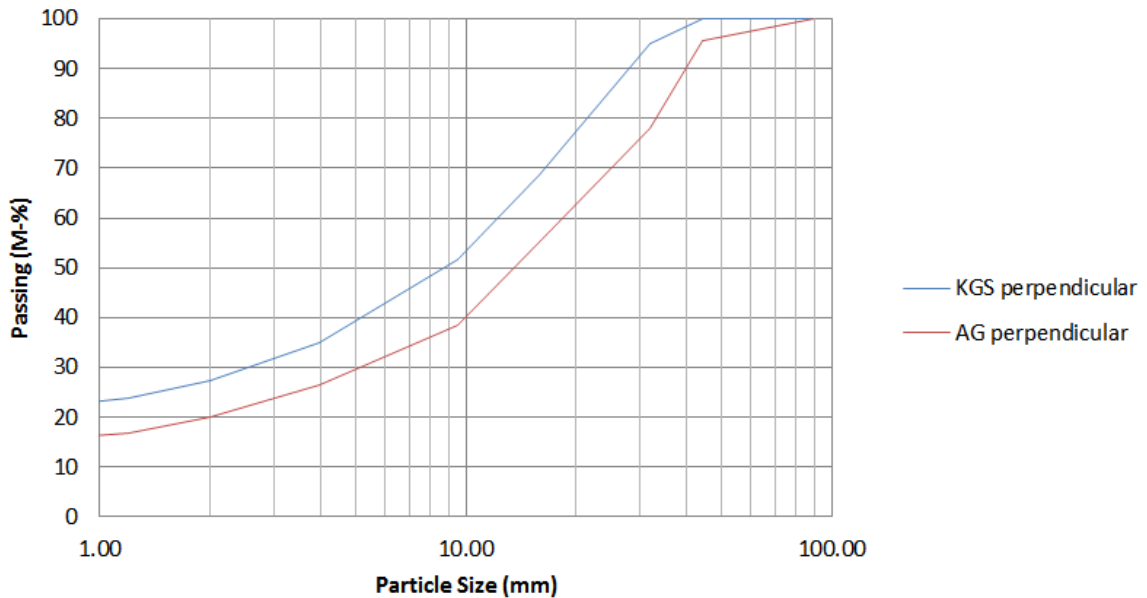

**Diagram 15: Sieve analysis of calcareous mica schist and augen gneiss with perpendicular foliation direction, a spacing of 80 mm and a penetration of 7.6 mm**

For oblique foliation direction, a spacing of 100 mm, and a penetration of 7.6 mm calcareous mica schist has the highest content of fine grains (20 M-%), schistose gneiss lies in the middle (16 M-%) and augen gneiss has the lowest content of fine grains (13 M-%) (shown in Diagram 16). Schistose gneiss has a higher content of coarse grains than calcareous mica schist and augen gneiss, which differ just slightly from each other.

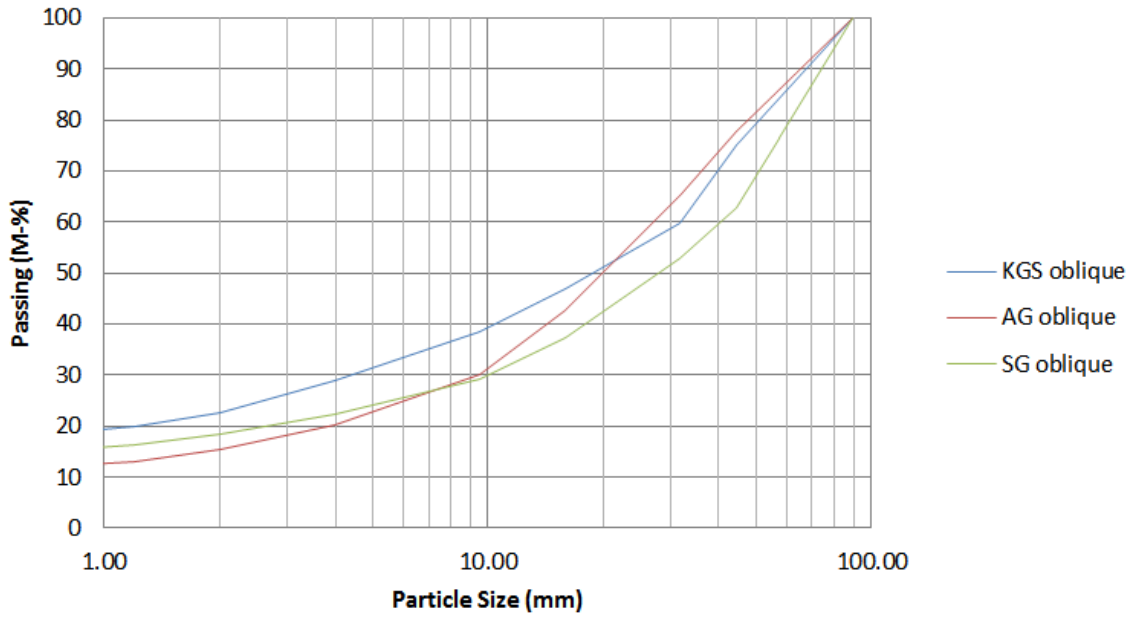

**Diagram 16: Sieve analysis of all rock types with oblique foliation direction, a spacing of 100 mm and a penetration of 7.6 mm**

In Diagram 17 is shown that calcareous mica schist has with 16 M-% a higher content of fine grains than augen gneiss with 14 M-% for parallel foliation direction, a spacing of 100 mm, and a penetration of 7.6 mm. The grain distribution curves of calcareous mica schist and augen gneiss differ just slightly and calcareous mica schist gets coarser than augen gneiss with increasing particle size.

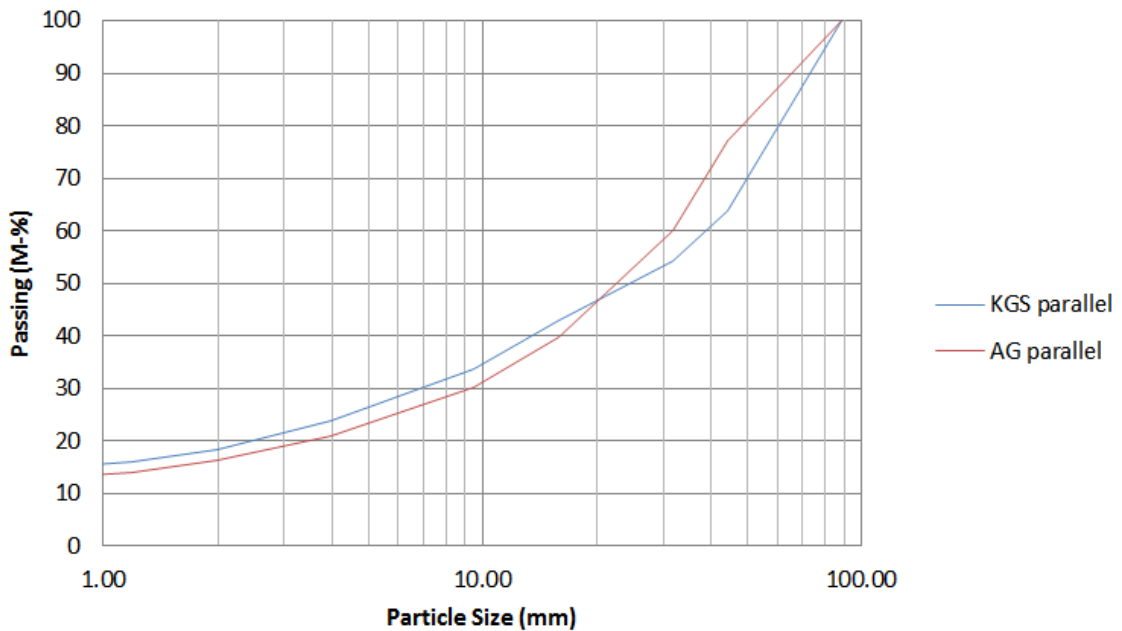

**Diagram 17: Sieve analysis of calcareous mica schist and augen gneiss with parallel foliation direction, a spacing of 100 mm and a penetration of 7.6 mm**

According to Diagram 18 calcareous mica schist has with 20 M-% a higher content of fine grains than augen gneiss with 11 M-% for perpendicular foliation direction, a spacing of 100 mm and a penetration of 7.6 mm. Augen gneiss is coarser grained than calcareous mica schist for these cutting parameters.

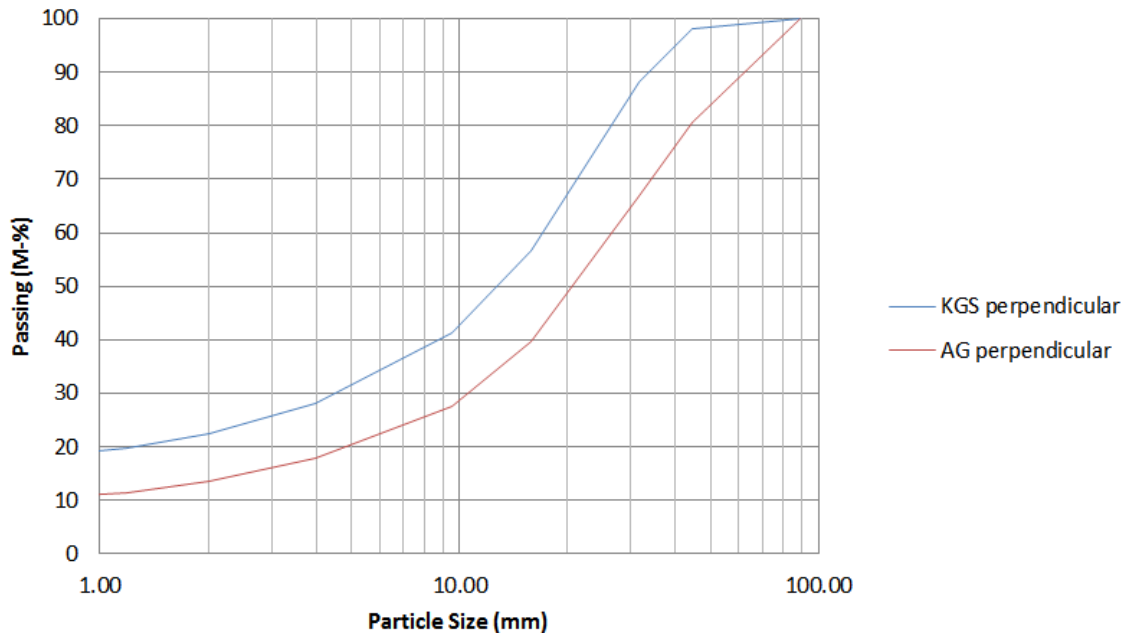

**Diagram 18: Sieve analysis of calcareous mica schist and augen gneiss with perpendicular foliation direction, a spacing of 100 mm and a penetration of 7.6 mm**

Diagram 19 to Diagram 34 show the grading curves for the individual rock types. For the calcareous mica schist and for the augen gneiss the grading curves of all foliation directions for one spacing-penetration combination are compared. For all rock types all spacing-penetration combinations of one foliation direction are also compared. Tables of the grading curves of all measurement passes are given in Appendix A.

#### 4.2.1 Calcareous Mica Schist

Diagram 19 to Diagram 22 show the comparison of the average grading curves for all foliation directions of calcareous mica schist for all individual spacing-penetration combinations. Samples of perpendicular calcareous mica schist have the highest content of fine grains with all spacing-penetration combinations, whereas samples of massive calcareous mica schist have the lowest content of fine grains.

Diagram 19 indicates that for the spacing-penetration combination 60-5.1 mm calcareous mica schist with perpendicular foliation direction has with 30 M-% the highest content of fine grains, followed by oblique foliation

direction with 27 M-%, parallel foliation direction with 25 M-%, and massive with 25 M-%. The sieve curves of calcareous mica schist with oblique, parallel and massive foliation direction differ just slightly and are coarser than that with perpendicular foliation direction.

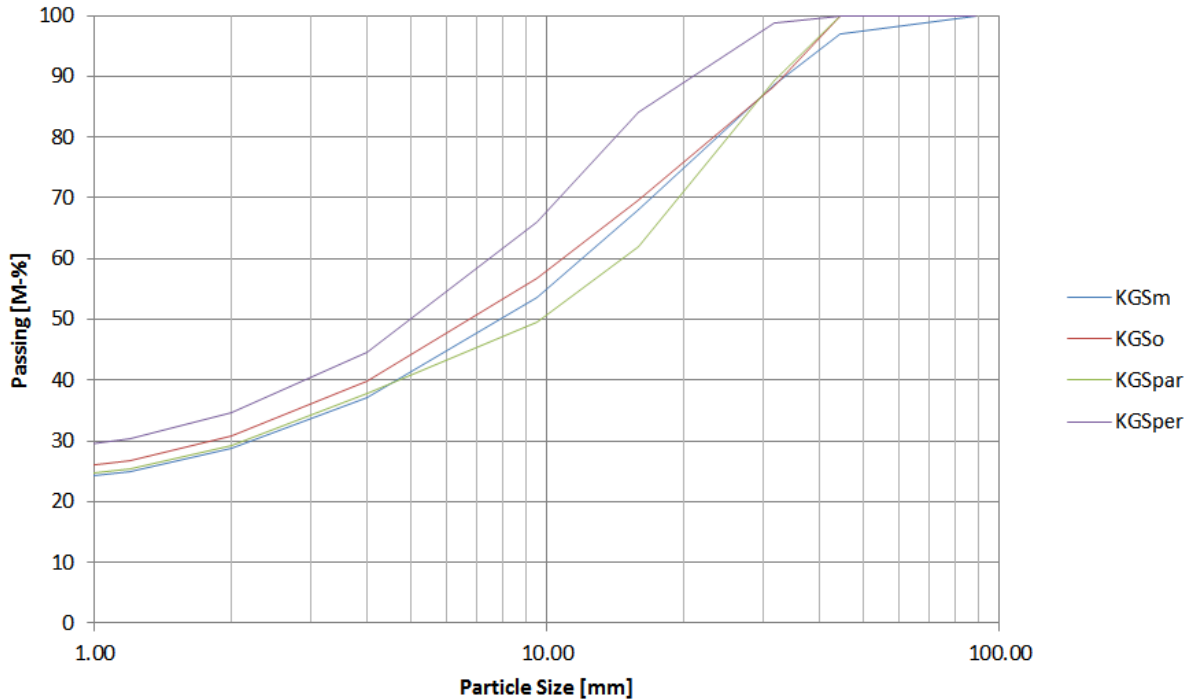

**Diagram 19: Sieve analysis of calcareous mica schist with a spacing of 60 mm and a penetration of 5.1 mm**

For the spacing-penetration combination 60-7.6 mm the quantity of fine grains is with 30 M-% highest for perpendicular foliation direction, followed by parallel foliation direction with 28 M-%, oblique foliation direction with 27 M-%, and massive with 23 M-% (shown in Diagram 20). Calcareous mica schist with perpendicular foliation direction is finer grained over all particle sizes than the other foliation directions, which lie closer to each other at higher particle sizes.



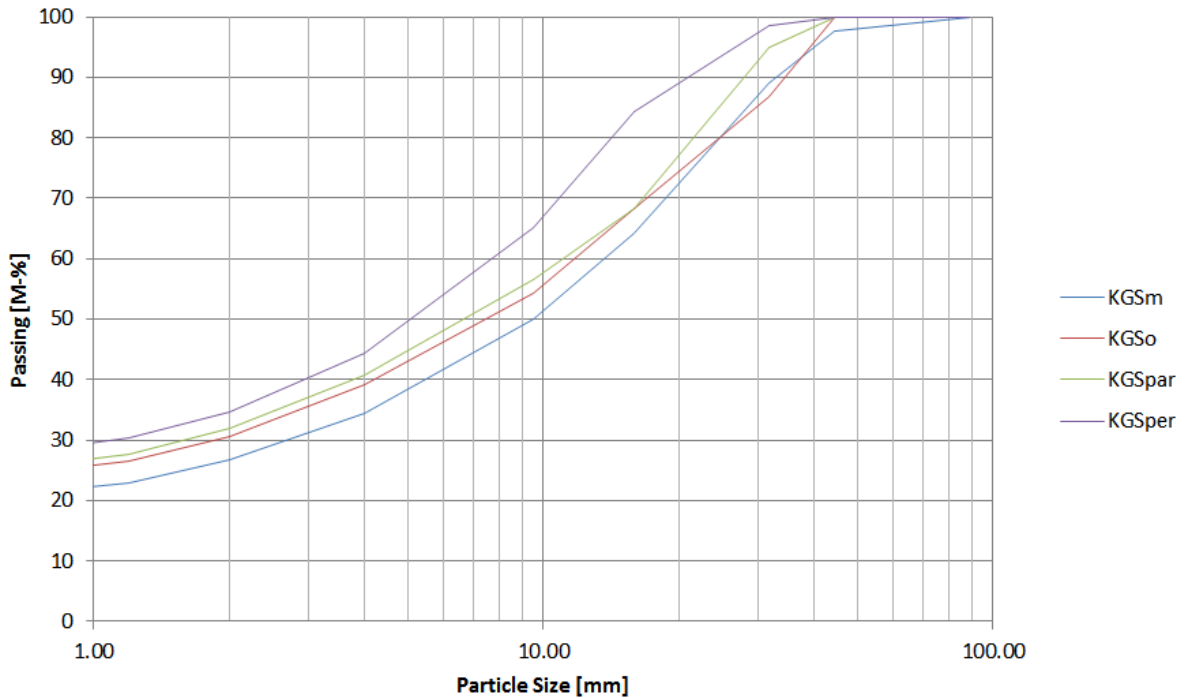

**Diagram 20: Sieve analysis of calcareous mica schist with a spacing of 60 mm and a penetration of 7.6 mm**

Diagram 21 shows that for the spacing-penetration combination 80-7.6 mm calcareous mica schist with perpendicular foliation direction has with 24 M-% the highest quantity of fine grains and with oblique foliation with 19 M-% the lowest quantity of fine grains. The content of fine grains of parallel and massive calcareous mica schist lies between with 22 and 20 M-%. The grain distribution curve of calcareous mica schist with oblique foliation is coarser than those of the other foliation direction and the sieve curve of perpendicular calcareous mica schist is the finest.

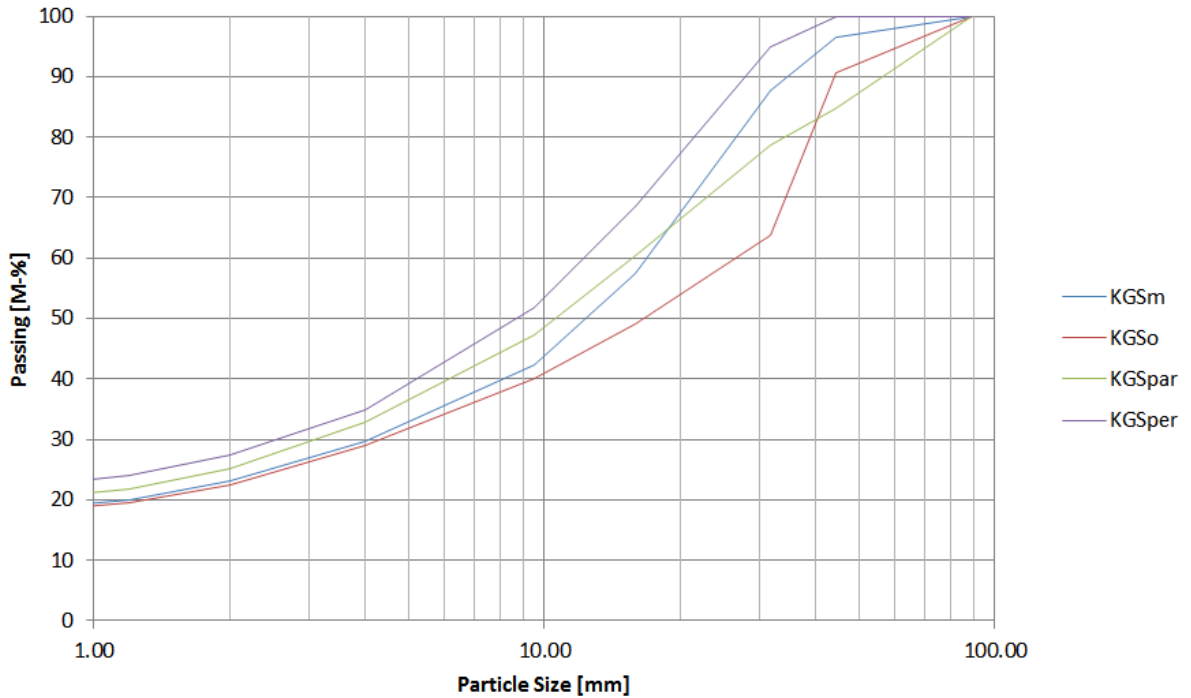

**Diagram 21: Sieve analysis of calcareous mica schist with a spacing of 80 mm and a penetration 7.6 mm**

Diagram 22 indicates that for a spacing-penetration combination of 100-7.6 mm calcareous mica schist with perpendicular and oblique foliation direction has with 20 M-% the highest content of fine grains. The lowest content of fine grains with 10 M-% has calcareous mica schist with parallel foliation direction, the second lowest has massive calcareous mica schist with 16 M-%. The grain distribution curve of massive calcareous mica schist is coarser than that with parallel and oblique foliation direction. The finest sieve curve has calcareous mica schist with perpendicular foliation direction.

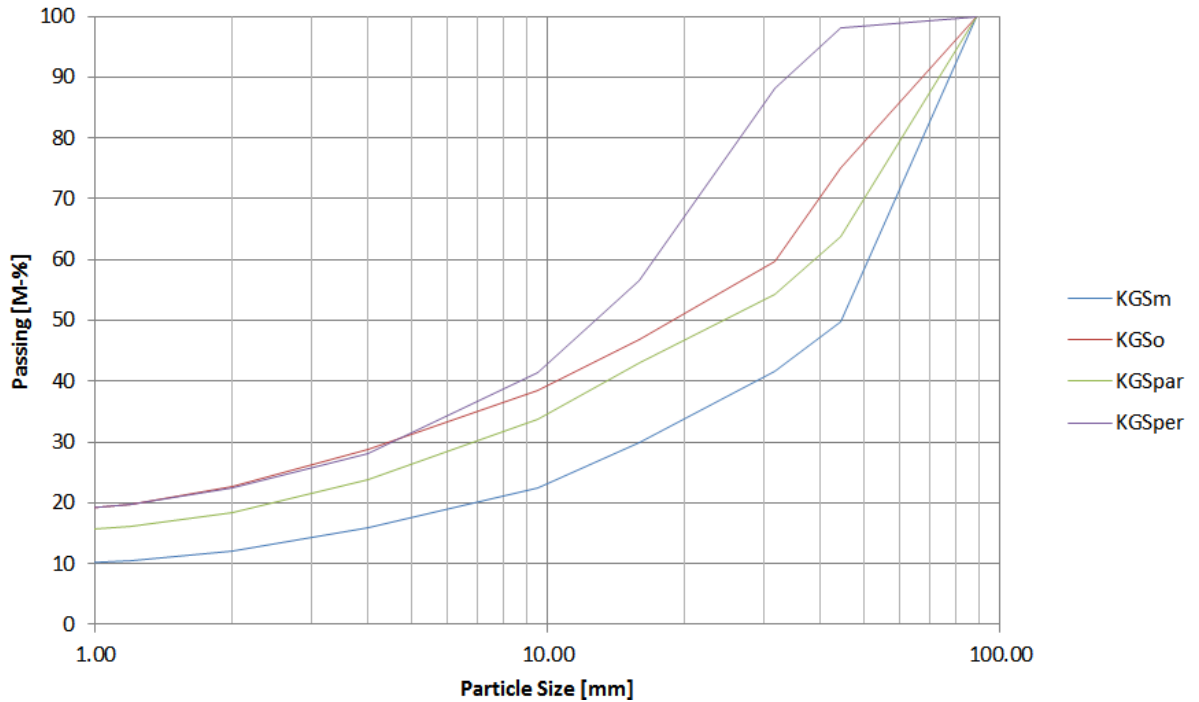

**Diagram 22: Sieve analysis of calcareous mica schist with a spacing of 100 mm and a penetration of 7.6 mm**

Diagram 23 through Diagram 26 show the comparison of the averaged grading curves of all spacing-penetration combinations for all individual foliation directions. They indicate that the sieve samples get finer grained with decreasing spacing for all foliation directions.

For massive calcareous mica schist increases the content of fine grains with decreasing spacing and penetration (shown in Diagram 23). For the spacing-penetration combination 100-7.6 mm the content of fine grains is 10 M-%, for the combination 80-7.6 mm 20 M-%, for the combination 60-7.6 mm 23 M-% and for the combination 60-5.1 mm 25 M-%. The sieve curves get coarser with increasing spacing, where the sieve curve of the spacing-penetration combination 100-7.6 mm has the biggest difference to the other curves.

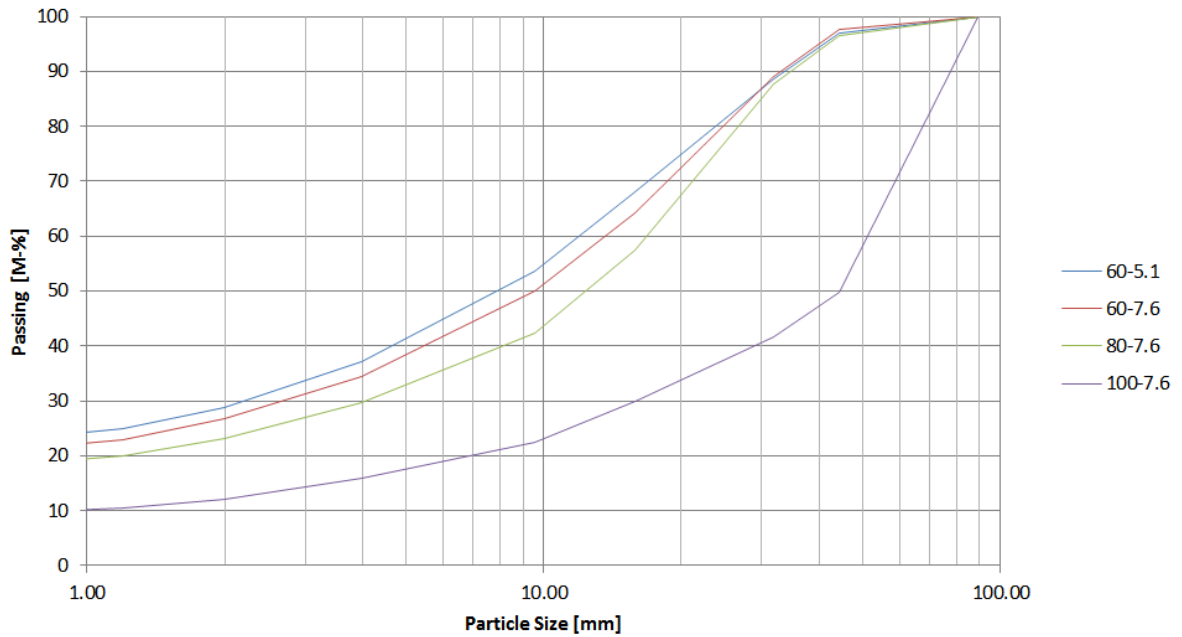

**Diagram 23: Sieve analysis of calcareous mica schist with massive foliation**

Diagram 24 indicates that for calcareous mica schist with oblique foliation direction the content of fine grains increases from 20 M-% for the spacing-penetration combinations 100-7.6 and 80-7.6 mm to 27 M-% for the combinations 60-7.6 and 60-5.1 mm. The sieve curves of the spacing-penetration combinations 100-7.6 and 80-7.6 mm are coarser than the curves of the combinations 60-7.6 and 60-5.1 mm over all particle sizes.

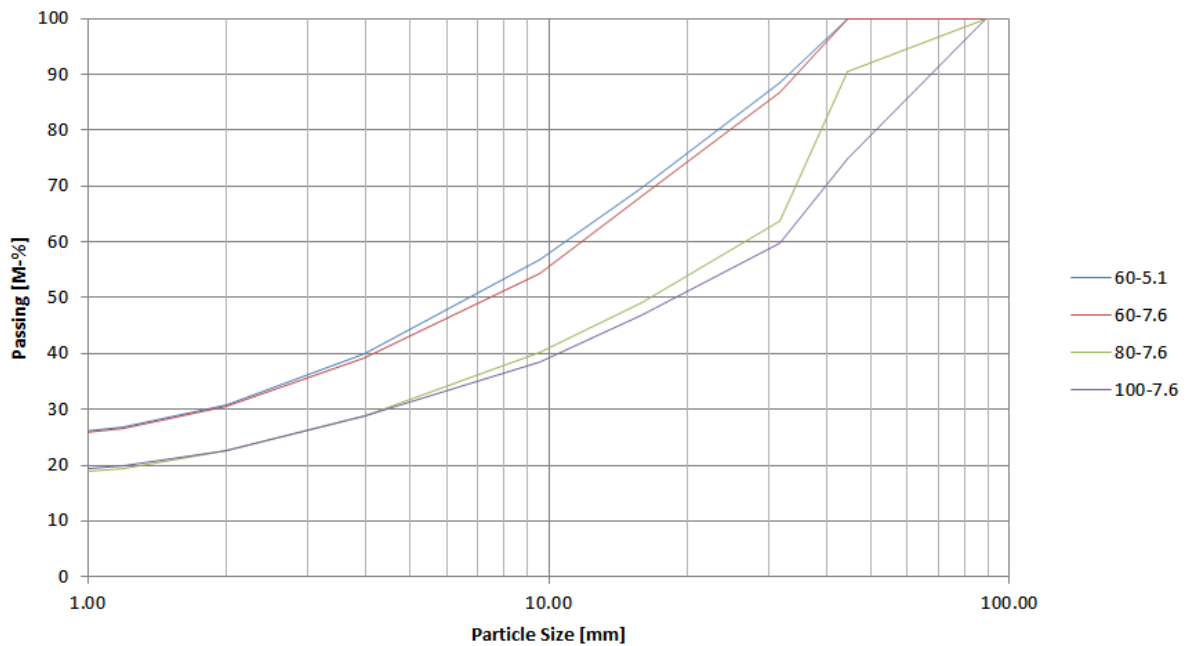

**Diagram 24: Sieve analysis of calcareous mica schist with oblique foliation direction**

Diagram 25 indicates that the quantity of fine grains for calcareous mica schist with parallel foliation direction increases from 16 M-% for the spacing-penetration combination 100-7.6 mm, over 22 M-% for the combination 80-7.6 mm, and 25 M-% for the combination 60-5.1 mm to 28 M-% for the combination 60-7.6. The grain distribution curves develop in the same way as the content of fine grains over all particle sizes.

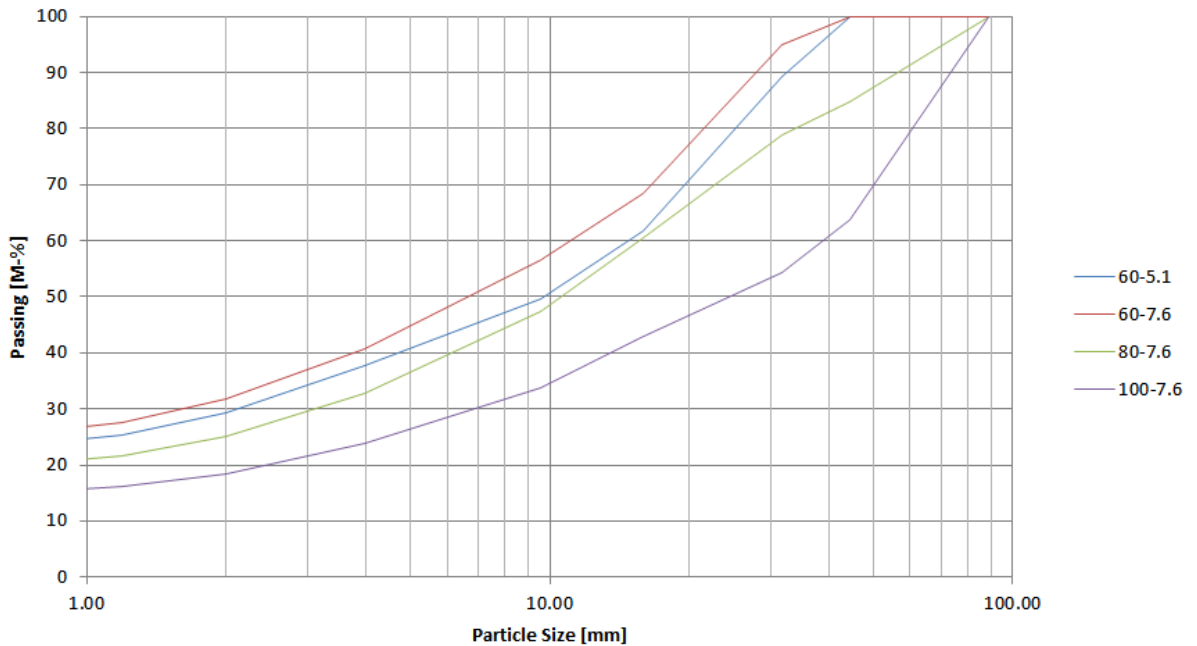

**Diagram 25: Sieve analysis of calcareous mica schist with parallel foliation direction**

The quantity of fine grains increases with decreasing spacing for calcareous mica schist with perpendicular foliation direction (see Diagram 26). The content of fine grains for the spacing-penetration combination 100-7.6 mm is 20 M-%, for the combination 80-7.6 mm 24 M-%, for the combinations 60-7.6 and 60-5.1 mm 30 M-%. The spacing-penetration combinations with the lower contents of fine grains also have coarser sieve curves.

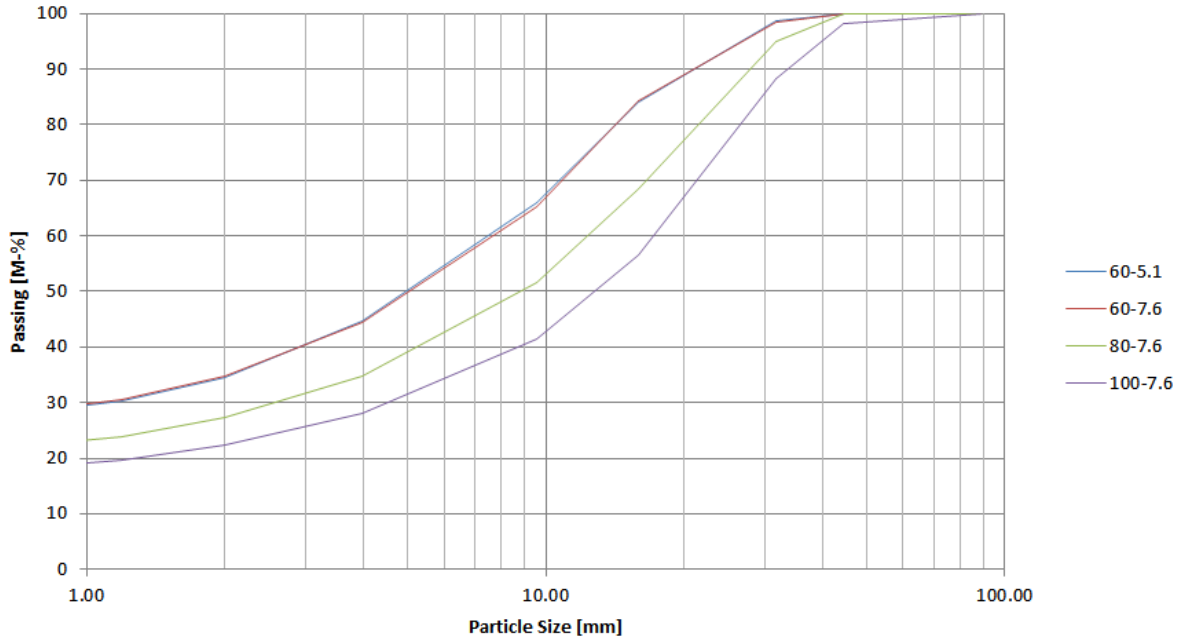
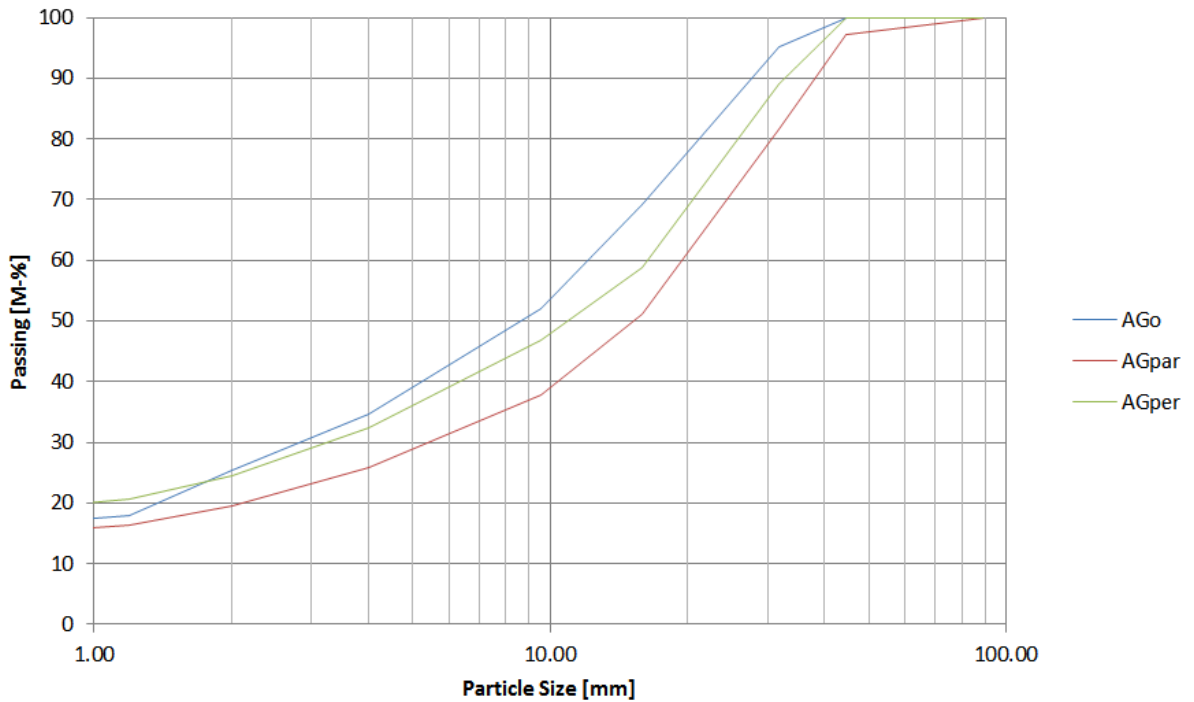

**Diagram 26: Sieve analysis of calcareous mica schist with perpendicular foliation direction**

#### 4.2.2 Augen Gneiss

Diagram 27 through Diagram 30 show the comparison of the average grading curves of all foliation directions of augen gneiss for the individual spacing-penetration combinations. The diagrams show that the content of fine grains is not obviously influenced by the foliation direction of augen gneiss.

Diagram 27 indicates that for the spacing-penetration combination 60-5.1 mm augen gneiss with perpendicular foliation direction has with 21 M-% the highest content of fine grains, followed by augen gneiss with oblique foliation direction with 18 M-% and augen gneiss with parallel foliation direction with 16 M-%. The grain size distribution curve of parallel augen gneiss is the coarsest, perpendicular augen gneiss lies in the middle and oblique augen gneiss is the finest.



**Diagram 27: Sieve analysis of augen gneiss with a spacing of 60 mm and a penetration of 5.1 mm**

For the spacing-penetration combination 80-7.6 mm augen gneiss with oblique foliation direction has with 21 M-% a slightly higher quantity of fine grains than augen gneiss with parallel and perpendicular foliation direction with 20 M-% (see Diagram 28). Augen gneiss with parallel foliation direction is coarser grained than with the other foliation direction, which differ just slightly from each other.

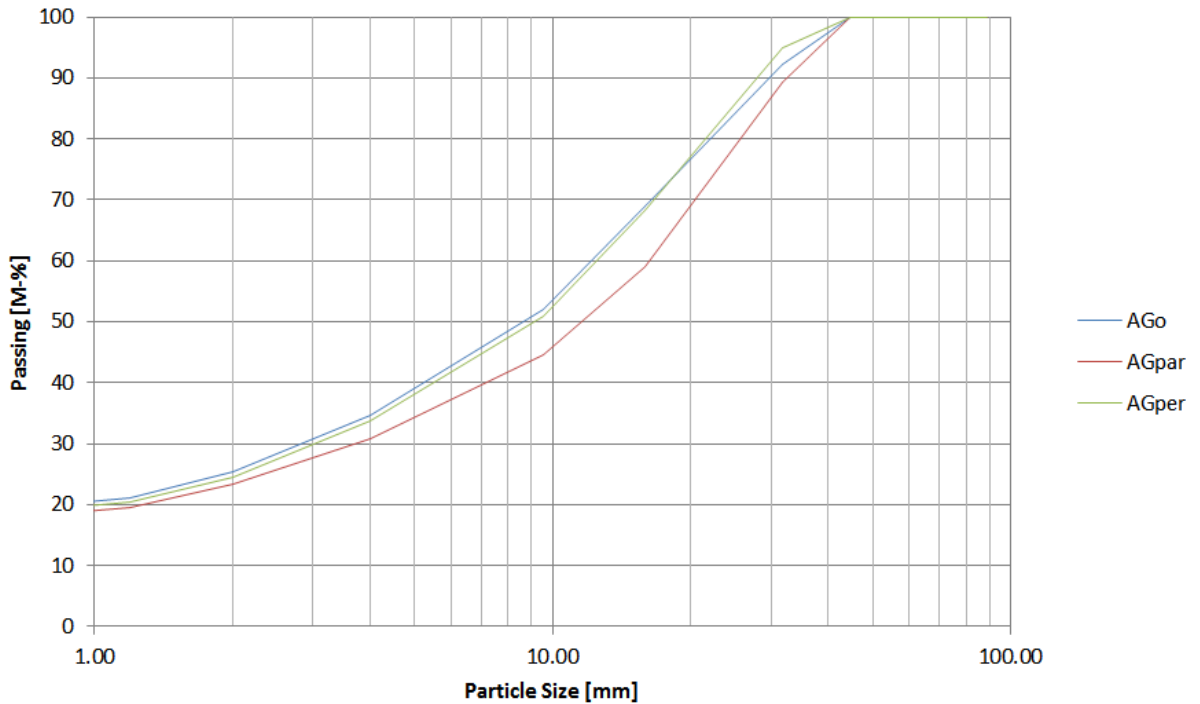

**Diagram 28: Sieve analysis of augen gneiss with a spacing of 80 mm and a penetration of 7.6 mm**

Diagram 29 shows that augen gneiss with parallel foliation direction has with 19 M-% a slightly higher content of fine grains than with oblique and perpendicular foliation direction with 17 M-%. The sieve curves of augen gneiss with the three foliation direction differ just a little from each other.

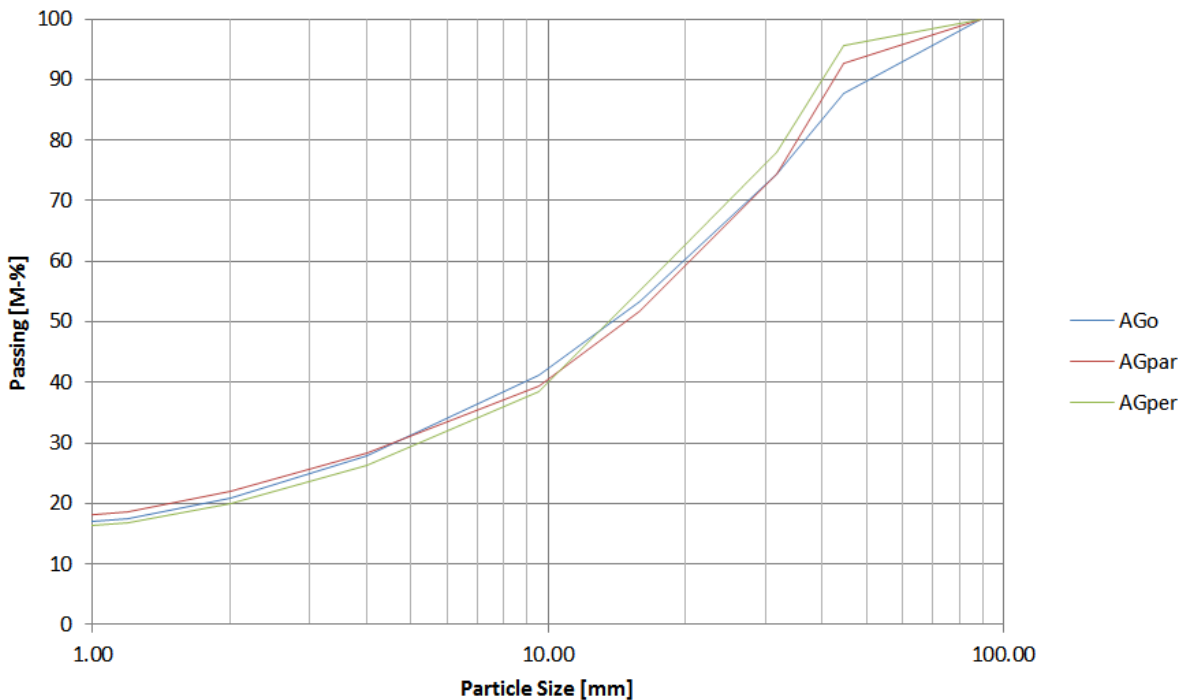

**Diagram 29: Sieve analysis of augen gneiss with a spacing of 80 mm and a penetration of 7.6 mm**



Diagram 30 indicates that for the spacing-penetration combination 100-7.6 mm augen gneiss with parallel foliation direction has with 14 M-% the highest content of fine grains, followed by augen gneiss with oblique foliation direction with 13 M-% and augen gneiss with perpendicular foliation direction with 11 M-%. The grain distribution curves of augen gneiss with the three foliation directions differ just slightly.

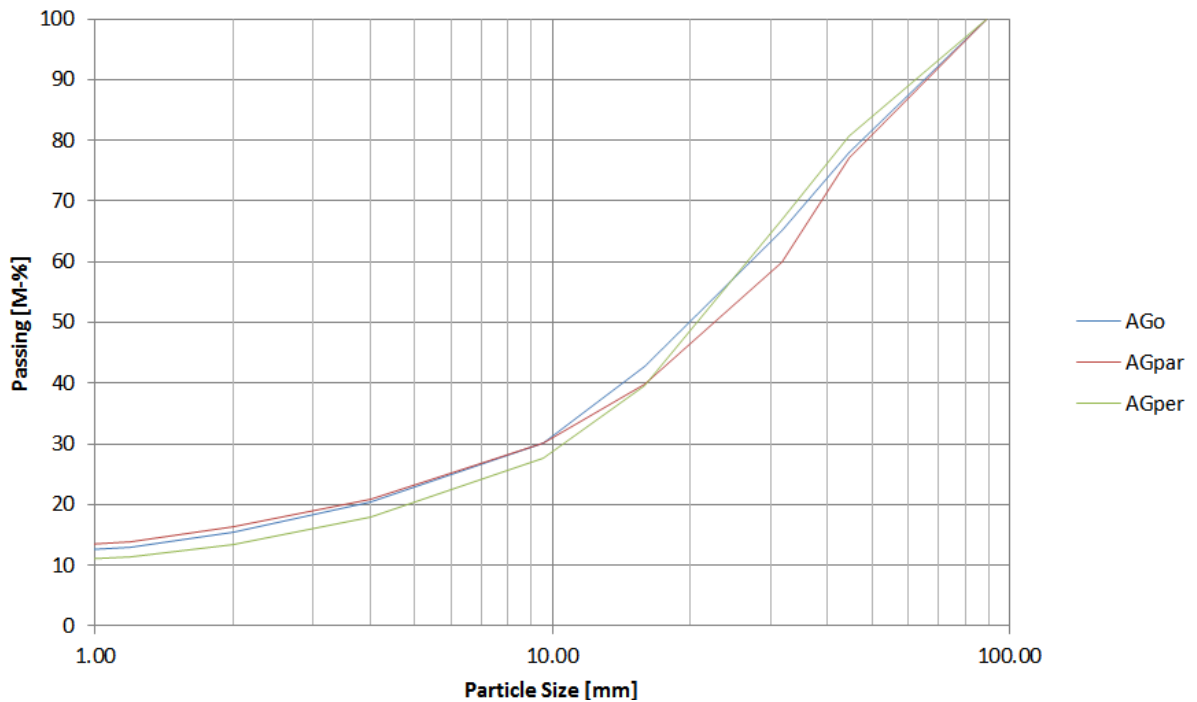

**Diagram 30: Sieve analysis of augen gneiss with a spacing of 100 mm and a penetration of 7.6 mm**

Diagram 31 through Diagram 33 compare the averaged grading curves of all spacing-penetration combinations of augen gneiss for all individual foliation directions with each other. They indicate that in general the sieve samples get finer grained with decreasing spacing.

Diagram 31 indicates that the quantity of fine grains increases with decreasing spacing for augen gneiss with oblique foliation direction. Augen gneiss with the spacing penetration combination 60-7.6 mm has with 21 M-% the highest content of fine grains, followed by the spacing-penetration combination 60-5.1 mm with 18 M-%, the spacing-penetration combination 80-7.6 mm with 17 M-% and the spacing-penetration combination 100-7.6 mm with 13 M-%. The sieve curve of the spacing-penetration combination 100-7.6 mm is the coarsest, the combination 80-7.6 mm lies in between and the combinations 60-7.6 and 60-5.1 mm are the least coarse and differ not much from each other.

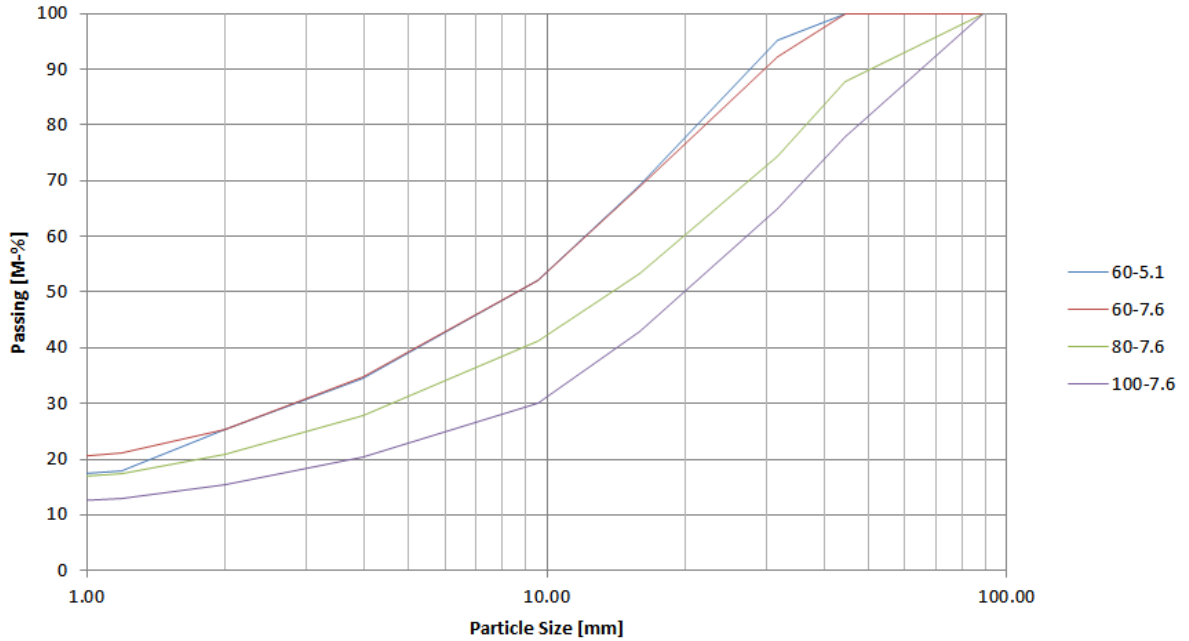

**Diagram 31: Sieve analysis of augen gneiss with oblique foliation direction**

Diagram 32 shows that for augen gneiss with parallel foliation direction the spacing-penetration combination 60-7.6 mm has with 20 M-% the highest quantity of fine grains. The content of fine grains for the combination 80-7.6 is with 19 M-% the second highest, the combination 60-5.1 mm has a content of 16 M-% and the combination 100-7.6 mm a content of 14 M-%. The grain distribution curve of the combination 100-7.6 mm is the coarsest, the curve of the combination 60-7.6 mm the finest and the combinations 60-7.6 and 80-7.6 mm lie in the middle.

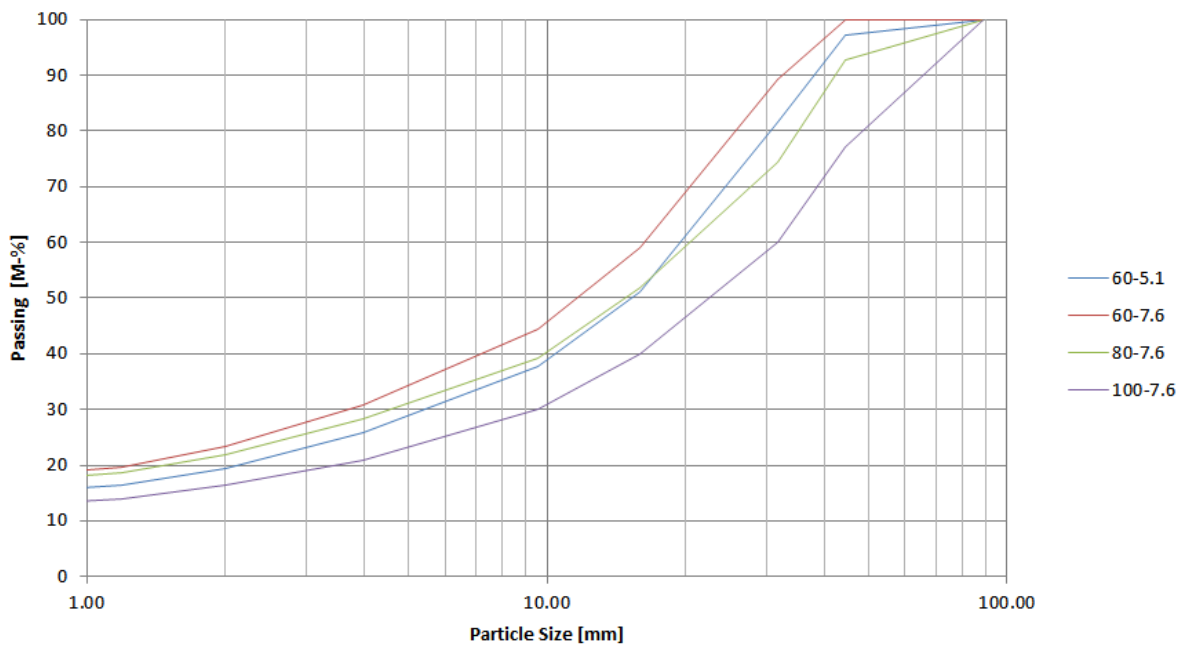

**Diagram 32: Sieve analysis of augen gneiss with parallel foliation direction**

For augen gneiss with perpendicular foliation direction the content of fine grains increases with decreasing spacing (shown in Diagram 33). It is for the spacing-penetration combination 60-5.1 and 60-7.6 mm 20 M-%, for the combination 80-7.6 mm 17 M-% and for the combination 100-7.6 mm 11 M-%. The sieve curve of the spacing-penetration combination of 100-7.6 mm is the coarsest followed by the combination 80-7.6 mm, the combination 60-5.1 mm and the combination 60-7.6 mm.

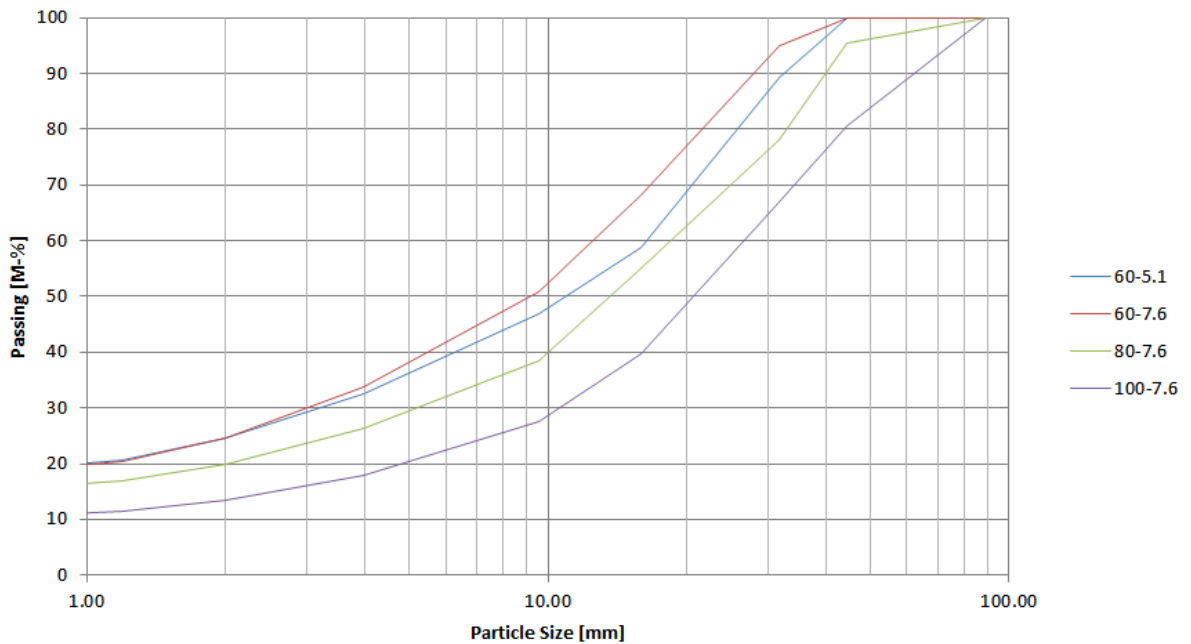

**Diagram 33: Sieve analysis of augen gneiss with perpendicular foliation direction**

### 4.2.3 Schistose Gneiss

In Diagram 34, the averaged grading curves of all spacing-penetration combinations for schistose gneiss with oblique foliation direction are compared with each other. It shows that the sieve samples get finer grained with decreasing spacing and penetration. Oblique schistose gneiss with the spacing-penetration combination 60-5.1 mm has with 31 M-% the highest content of fine grains followed by 60-7.6 mm with 25 M-%, 80-7.6 mm with 23 M-% and 100-7.6 mm with 16 M-%.

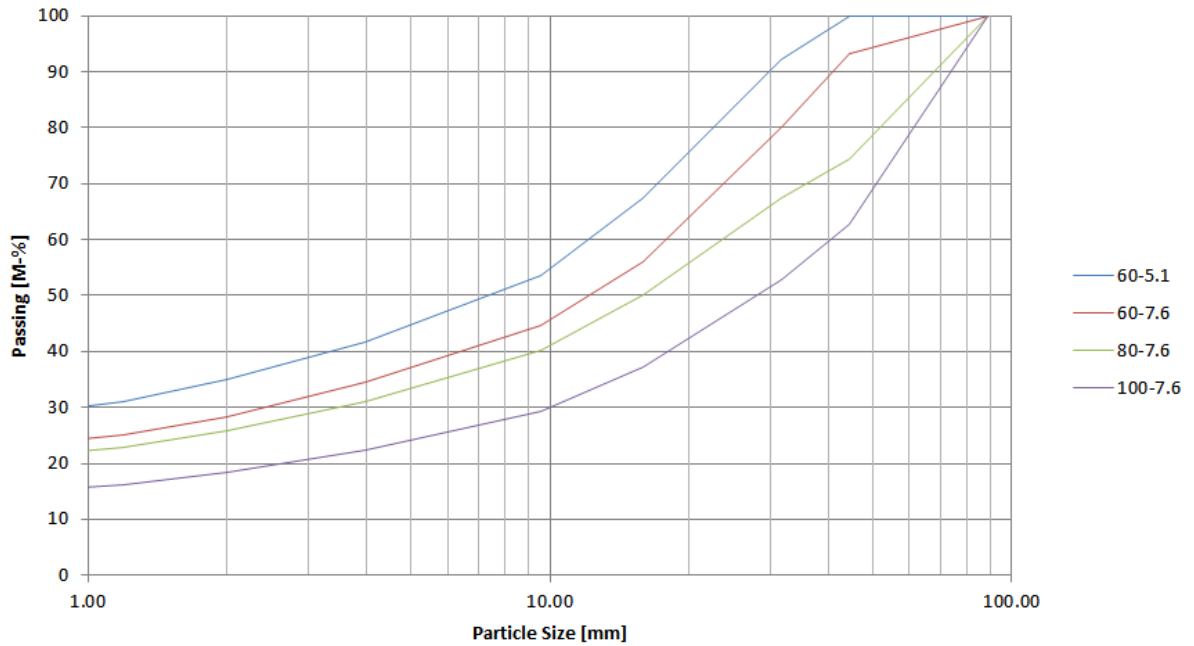

**Diagram 34: Sieve analysis of oblique schistose gneiss**

### 4.3 Specific Energy

The specific energy is plotted by the spacing-penetration ratio for all rock types and foliation directions in Diagram 35. In Diagram 36, the specific energy is plotted by the percentage of grains with a particle size <1.19 mm. It indicates that the specific energy increases with increasing percentage of fine grains. Table 14 shows the specific energy and the percentage of fine grains (<1.19 mm) for all rock types, foliation directions and spacing-penetration combinations. It can be seen that the rock types and foliation directions also have an influence on the specific energy.

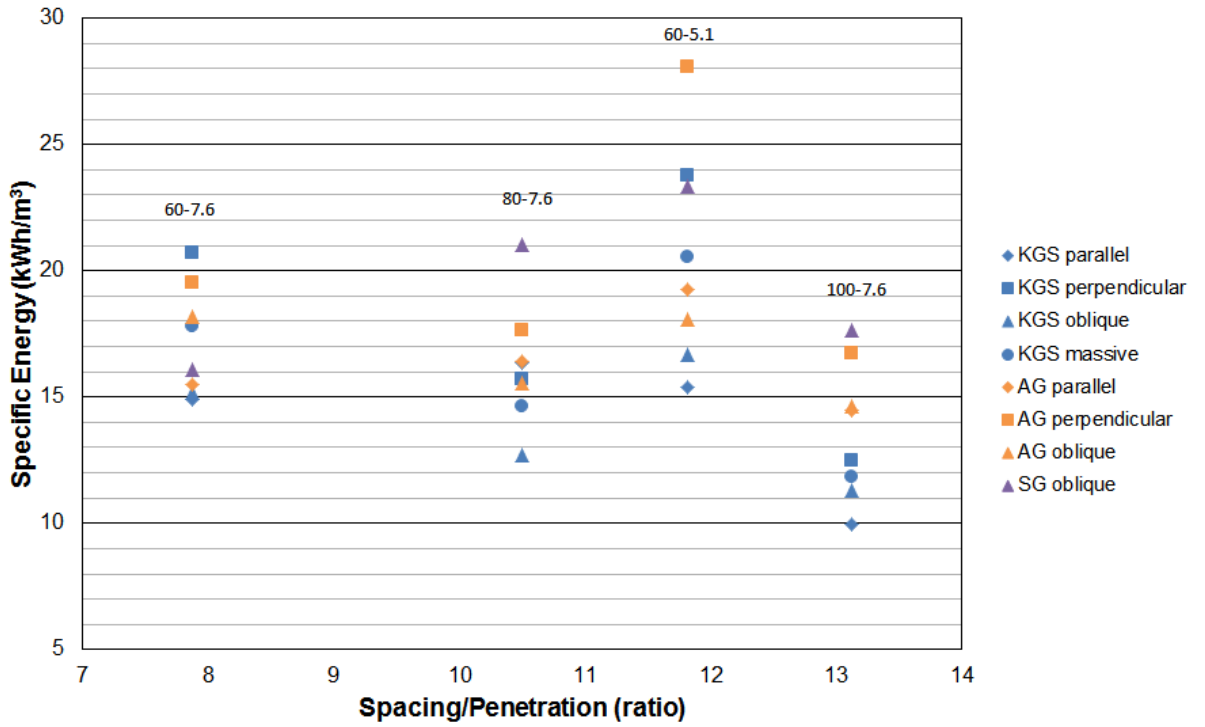

Diagram 35: Specific energy by spacing-penetration ratio for all rock types

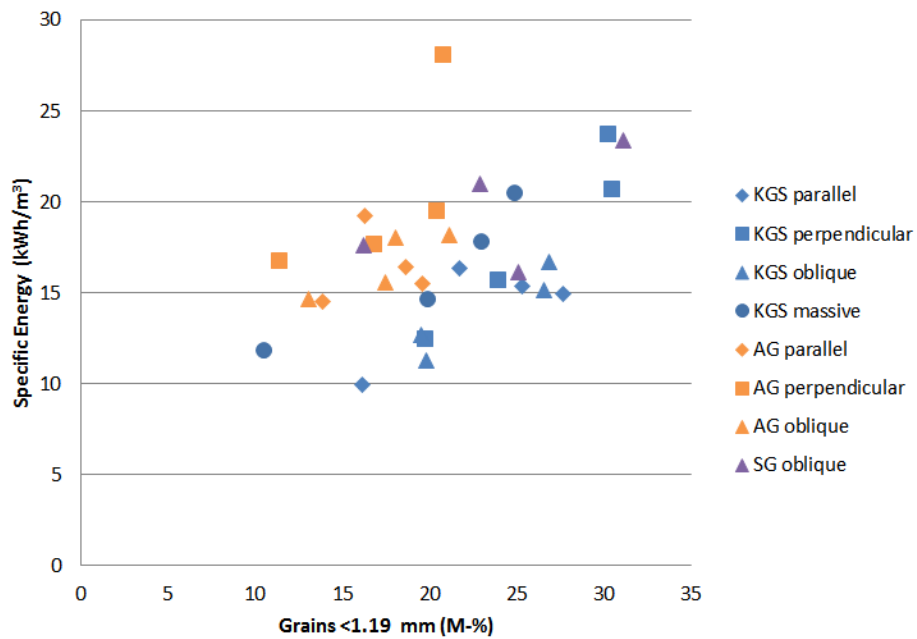

Diagram 36: Specific energy by the percentage of grains with a particle size <1.19 mm for all rock types

Rock Type	Foliation Direction	Spacing (mm)	Penetration (mm)	Specific Energy (kWh/m <sup>3</sup> )	M-% grains <1.19 mm
KGS	parallel	60	5.1	15.4	25.3
		60	7.6	14.9	27.7
		80	7.6	16.3	21.7
		100	7.6	9.9	16.1
	perpendicular	60	5.1	23.8	30.3
		60	7.6	20.7	30.4
		80	7.6	15.7	23.9
		100	7.6	12.5	19.7
	oblique	60	5.1	16.7	26.8
		60	7.6	15.2	26.5
		80	7.6	12.7	19.5
		100	7.6	11.3	19.8
	massive	60	5.1	20.5	24.9
		60	7.6	17.8	22.9
		80	7.6	14.7	19.9
		100	7.6	11.8	10.5
AG	parallel	60	5.1	19.2	16.3
		60	7.6	15.5	19.6
		80	7.6	16.4	18.6
		100	7.6	14.5	13.9
	perpendicular	60	5.1	28.1	20.7
		60	7.6	19.5	20.4
		80	7.6	17.7	16.8
		100	7.6	16.8	11.4
	oblique	60	5.1	18.1	18.0
		60	7.6	18.2	21.1
		80	7.6	15.6	17.5
		100	7.6	14.7	13.0
SG	oblique	60	5.1	23.4	31.1
		60	7.6	16.1	25.1
		80	7.6	21.0	22.9
		100	7.6	17.6	16.2

**Table 14: Specific energy and fine grains for all rock types and foliation directions**

#### 4.4 Aspect Ratios

Diagram 37 shows the average mass percentage of non-cubic grains for all rock types, foliation directions and spacing-penetration combinations. The influence of the foliation direction on the aspect ratios of calcareous mica schist as well as augen gneiss can be seen in the diagram. The influence of

spacing on the aspect ratios is apparent for each combination of rock type and foliation direction, but no universal relationship can be identified.

The percentage of non-cubic grains for parallel calcareous mica schist goes from 46 M-% for the spacing-penetration combination 100-7.6 mm over 53 M-% for the combination 80-7.6 and 60-7.6 mm to 66 M-% for the combination 60-5.1 mm (shown in Diagram 37).

The content of non-cubic grains for calcareous mica schist with perpendicular foliation direction reaches from 50 M-% for the spacing-penetration combination 100-7.6 mm over 56 M-% for the combination 60-5.1 and 58 M-% for the combination 60-7.6 mm to 59 M-% for the combination 80-7.6 mm.

For calcareous mica schist with oblique foliation the spacing-penetration combination 80-7.6 mm has with 86 M-% the lowest content of non-cubic grains followed by the combinations 60-5.1 and 60-7.6 mm with 88 M-% and the combination 100-7.6 mm with 92 M-%.

The quantity of non-cubic grains for massive calcareous mica schist goes from 81 M-% for the spacing-penetration combination 80-7.6 mm over 83 M-% for the combination 100-7.6 mm and 92 M-% for the combination 60-5.1 mm to 94 M-% for the combination 60-7.6 mm.

For augen gneiss with parallel foliation direction the spacing-penetration combination 60-5.1 mm has with 78 M-% the lowest content of non-cubic grains followed by 100-7.6 mm with 81 M-%, 60-7.6 mm with 82 M-% and 80-7.6 mm with 88 M-%.

The quantity of non-cubic grains for perpendicular augen gneiss goes from 66 M-% for the spacing-penetration combination 60-7.6 mm over 72 M-% for the combination 100-7.6 mm and 73 M-% for the combination 80-7.6 mm to 78 M-% for the combination 60-5.1 mm.

The content of non-cubic grains of augen gneiss with oblique foliation direction is with 56 M-% lowest for the spacing-penetration combination 80-7.6 mm, followed by 70 M-% for the combination 60-7.6 mm, 71 M-% for the combination 60-5.1 mm and 83 M-% for the combination 100-7.6 mm.

For schistose gneiss with oblique foliation direction the quantity of non-cubic grains reaches from 61 M-% for the spacing-penetration combination 100-7.6 mm over 70 M-% for the combination 80-7.6 mm and 79 M-% for the combination 60-7.6 mm to 82 M-% for the combination 60-5.1 mm.

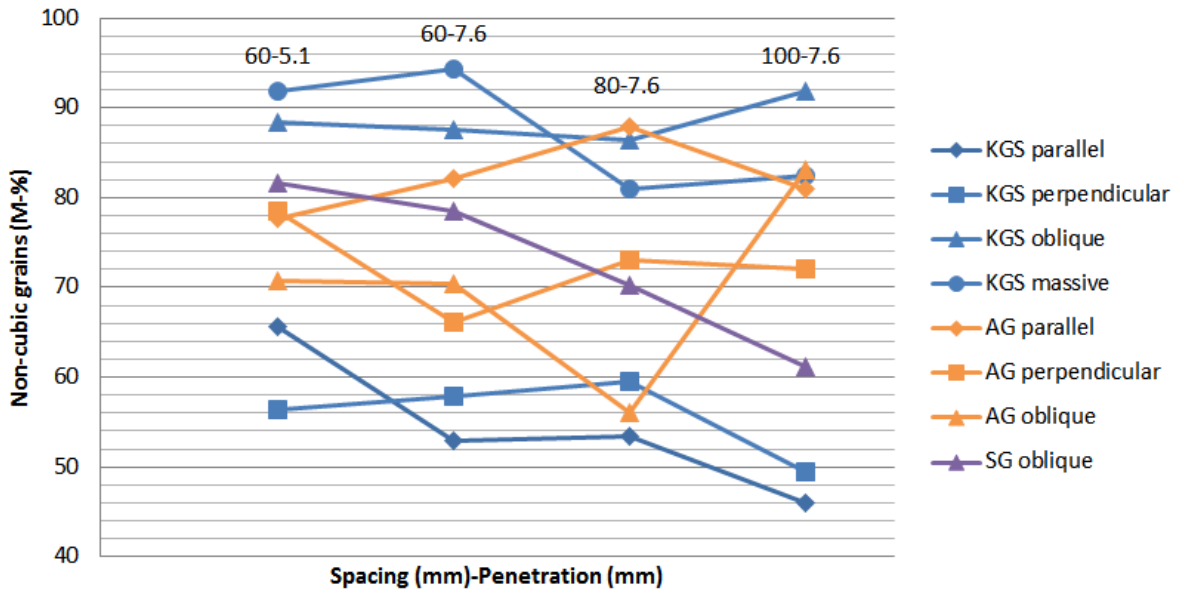

Diagram 37: Aspect ratio diagram

#### 4.4.1 Calcareous Mica Schist

Table 15 shows the average percentage of cubic and non-cubic grains for calcareous mica schist for all foliation directions and spacing-penetration combinations. The percentage of non-cubic grains of calcareous mica schist with oblique and massive foliation direction is significantly higher than that with parallel and perpendicular foliation direction.



Foliation Direction	Spacing (mm)	Penetration (mm)	M-% cubic grains	M-% non-cubic grains
parallel	60	5.1	34	66
	60	7.6	47	53
	80	7.6	47	53
	100	7.6	54	46
perpendicular	60	5.1	44	56
	60	7.6	42	58
	80	7.6	41	59
	100	7.6	50	50
oblique	60	5.1	12	88
	60	7.6	12	88
	80	7.6	14	86
	100	7.6	8	92
massive	60	5.1	8	92
	60	7.6	6	94
	80	7.6	19	81
	100	7.6	17	83

**Table 15: Aspect ratios of calcareous mica schist ordered by foliation direction, spacing and penetration**

Diagram 38 to Diagram 41 show the aspect ratios by the particle sizes of single passes for calcareous mica schist with massive foliation for all spacing-penetration combinations. For most of the samples the percentage of non-cubic grains increases slightly with increasing particle size. The aspect ratios of all other passes and foliation directions of calcareous mica schist can be found in Appendix B.

Diagram 38 shows that the percentage of non-cubic grains of the sample KGSm-P6-C7+8-60-5 drops from 95 M-% for the particle size 9.51 mm to 82 M-% for the particle size 16 mm and increases again to 100 M-% for the particle size 32 mm.

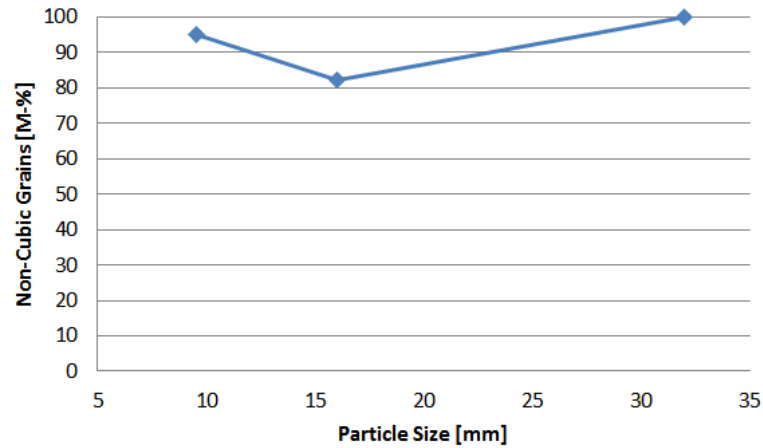

**Diagram 38: Aspect ratios of sample KGSm-P6-C7+8-60-5 by particle size**

For the sample KGSm-P7-C7+8-60-7.5 the percentage of non-cubic grains increases from 87 M-% for particle size 9.51 mm over 91 M-% for particle size 16 mm to 100 M-% for the particle sizes 32 and 45 mm (shown in Diagram 39).

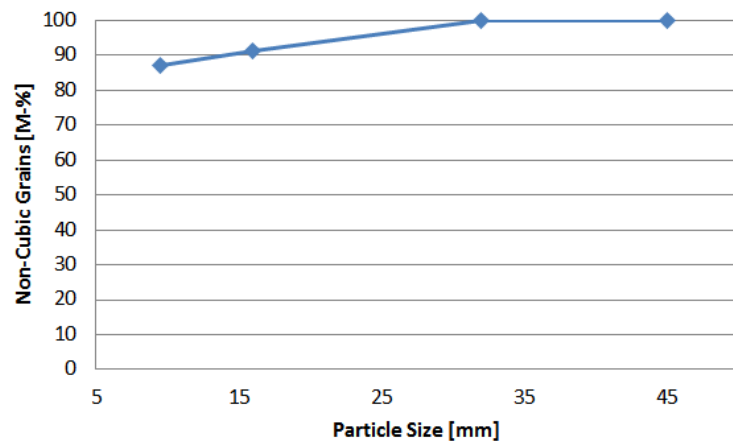

**Diagram 39: Aspect ratios of sample KGSm-P7-C7+8-60-7.5 by particle size**

Diagram 40 indicates that the percentage of non-cubic grains of the sample KGSm-P13-C6-80-7.5 increases from 70 M-% for the particle size 9.51 mm over 96 M-% for the particle size 16 mm to 100 M-% for the particle size 32 mm.

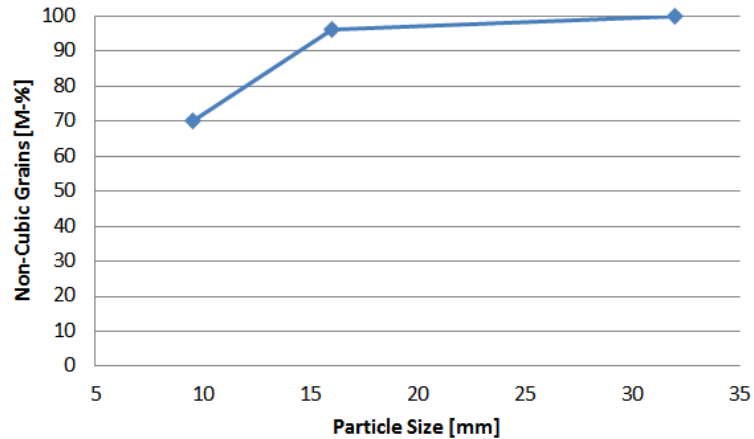

**Diagram 40: Aspect ratios of sample KGSm-P13-C6-80-7.5 by particle size**

Diagram 41 shows that the percentage of non-cubic grains drops from 69 M-% for the particle size 9.51 mm to 53 M-% for the particle size 16 mm and increases again to 83 M-% for the particle size 45 mm.

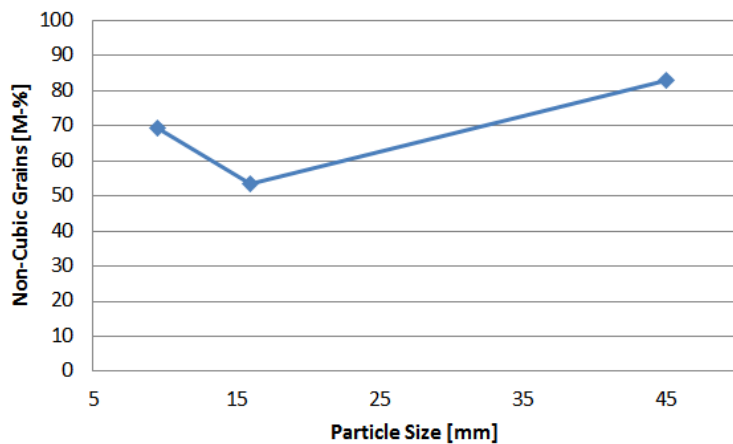

**Diagram 41: Aspect ratios of sample KGSm-P20-C6-100-7.5 by particle size**

#### 4.4.2 Augen Gneiss

Table 16 shows the average percentage of cubic and non-cubic grains for augen gneiss for all foliation directions and spacing-penetration combinations. The percentages of non-cubic grains of the three foliation directions do not significantly differ from each other.

Foliation Direction	Spacing (mm)	Penetration (mm)	M-% cubic grains	M-% non-cubic grains
parallel	60	5.1	22	78
	60	7.6	18	82
	80	7.6	12	88
	100	7.6	19	81
perpendicular	60	5.1	22	78
	60	7.6	34	66
	80	7.6	27	73
	100	7.6	28	72
oblique	60	5.1	29	71
	60	7.6	30	70
	80	7.6	44	56
	100	7.6	17	83

**Table 16: Aspect ratios of augen gneiss ordered by foliation direction, spacing and penetration**

Diagram 42 to Diagram 45 show the aspect ratios by the particle sizes of single passes for augen gneiss with perpendicular foliation for all spacing-penetration combinations. For most of the samples the percentage of non-cubic grains increases slightly with increasing particle size. The aspect ratios of all other passes and foliation directions of augen gneiss can be found in Appendix B.

Diagram 42 indicates that for the sample AGper-P3-C7+8-60-5 the percentage of non-cubic grains increases from 89 M-% for the particle size 9.51 mm over 91 M-% for the particle size 16 mm to 100 M-% for the particle size 32 mm.

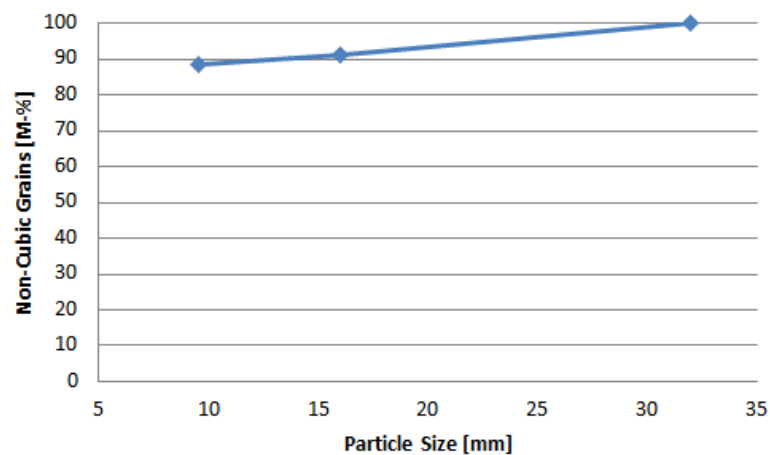

**Diagram 42: Aspect ratios of sample AGper-P3-C7+8-60-5 by particle size**

For the sample AGper-P9-C7+8-60-7.5 the percentage of non-cubic grains drops from 85 M-% for the particle size 9.51 mm to 76 M-% for the particle size 16 mm and increases again to 100 M-% for the particle size 32 mm (see Diagram 43).

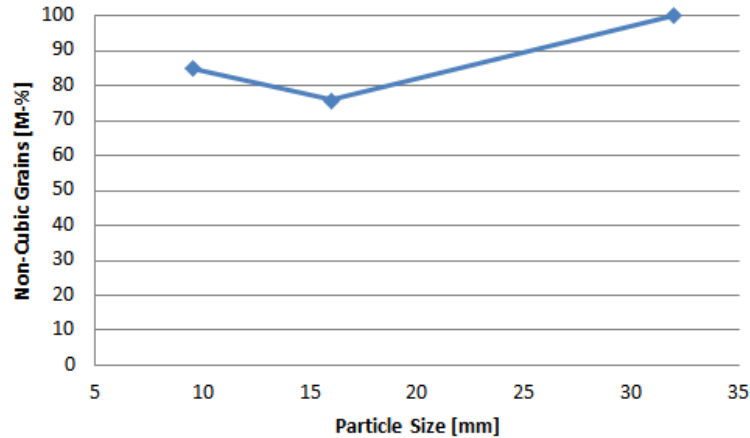

**Diagram 43: Aspect ratios of sample AGper-P9-C7+8-60-7.5 by particle size**

Diagram 44 shows that the percentage of non-cubic grains of the sample AGper-P13-C6-80-7.5 increases from 72 M-% for the particle size 9.51 mm over 87 M-% for the particle size 16 mm to 100 M-% for the particle sizes 32 and 45 mm.

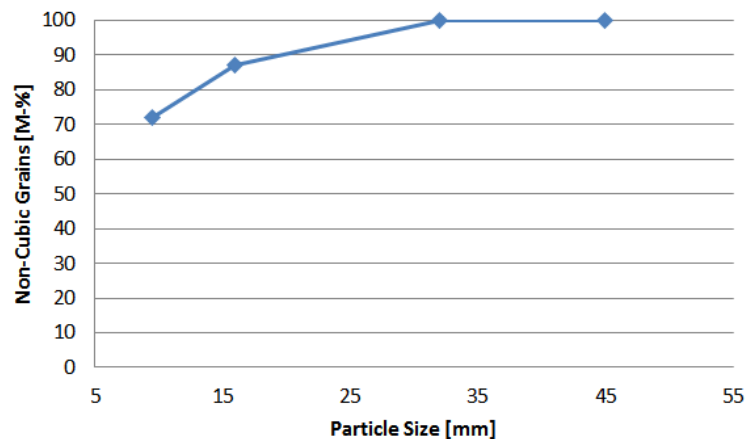

**Diagram 44: Aspect ratios of sample AGper-P13-C6-80-7.5 by particle size**

The percentage of non-cubic grains of the sample AGper-P20-C6-100-7.5 increases from 51 M-% for the particle size 9.51 mm over 53 M-% for the particle size 16 mm to 100 M-% for the particle sizes 32 and 45 mm (shown in Diagram 45).

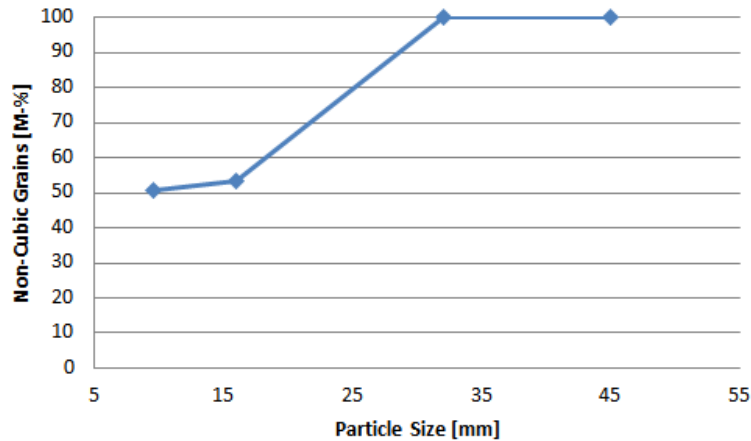

**Diagram 45: Aspect ratios of sample AGper-P20-C6-100-7.5 by particle size**

#### 4.4.3 Schistose Gneiss

Table 17 lists the average percentage of cubic and non-cubic grains for oblique schistose gneiss for all spacing-penetration combinations. It shows that the percentage of non-cubic grains increases with decreasing spacing and penetration.

Foliation Direction	Spacing (mm)	Penetration (mm)	M-% cubic grains	M-% non-cubic grains
oblique	60	5.1	18	82
	60	7.6	21	79
	80	7.6	30	70
	100	7.6	39	61

**Table 17: Aspect ratios of schistose gneiss ordered by spacing and penetration**

Diagram 46 to Diagram 49 show the aspect ratios by the particle sizes of single passes for schistose gneiss with oblique foliation for all spacing-penetration combinations. For most of the samples the percentage of non-cubic grains increases slightly with increasing particle size. The aspect ratios of all other passes and of schistose gneiss can be found in Appendix B.

Diagram 46 shows that the percentage of non-cubic grains of the sample SGo-P3-C2+3-60-5 increases from 84 M-% for the particle size 9.51 mm to 88 M-% for the particle size 16 mm.

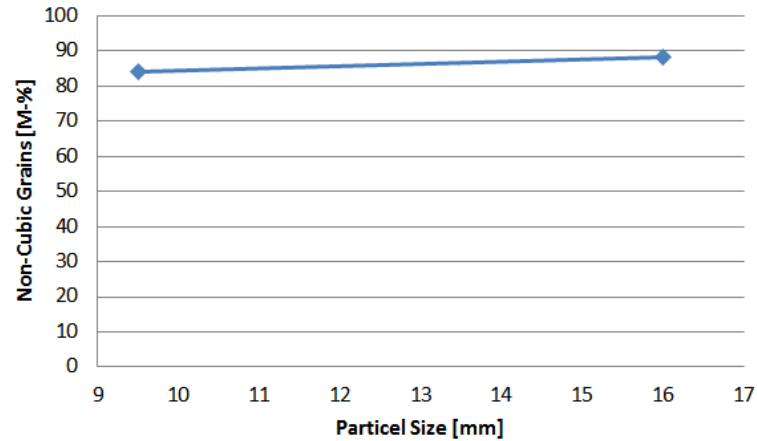

**Diagram 46: Aspect ratios of sample SGo-P3-C2+3-60-5 by particle size**

For the sample SGo-P7-C2+3-60-7.5 the percentage of non-cubic grains increases from 58 M-% for the particle size 9.51 mm over 82 M-% for the particle size 16 mm to 100 M-% for the particle size 32 mm (see Diagram 47).

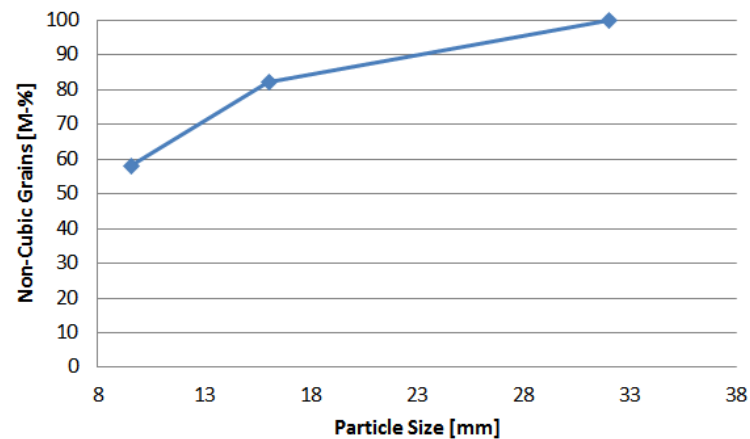

**Diagram 47: Aspect ratios of sample SGo-P7-C2+3-60-7.5 by particle size**

Diagram 48 indicates that the percentage of non-cubic grains increases from 43 M-% for the particle size 9.51 mm to 69 M-% for the particle size 16 mm, drops to 33 M-% for the particle size 32 mm and increases to 100 M-% for the particle size 45 mm.

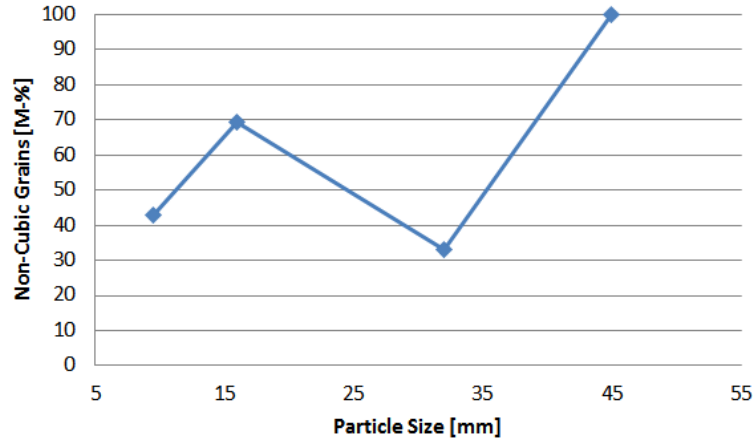

**Diagram 48: Aspect ratios of sample SGo-P13-C2-80-7.5 by particle size**

Diagram 49 shows that the percentage of non-cubic grains of the sample SGo-P20-C2-100-7.5 increases from 56 M-% for the particle size 9.51 mm over 59 M-% for the particle size 16 mm to 100 M-% for the particle size 45 mm.

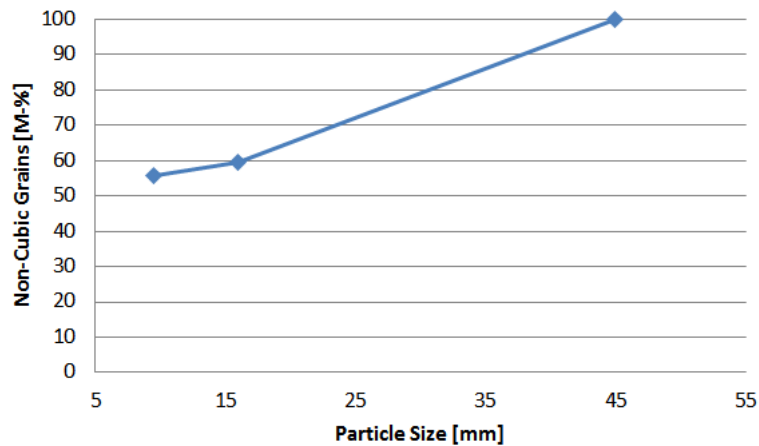

**Diagram 49: Aspect ratios of sample SGo-P20-C2-100-7.5 by particle size**



## **5 Conclusion, Interpretation and Discussion**

### **5.1 Forces**

It can be noted that the thrust increases with increasing penetration, but the thrust does not always increase with increased spacing, which indicates that the penetration may have a larger and more constant influence on the cutting forces than the spacing.

The cutability of calcareous mica schist increases for 60 mm spacing from perpendicular over massive and parallel to oblique. For 80 mm spacing, it increases from perpendicular over parallel and massive to oblique and for 100 mm spacing from perpendicular over massive to parallel and oblique. The cutability increases for augen gneiss with a spacing of 60 mm from perpendicular over parallel to oblique and for 80 and 100 mm spacing from parallel over perpendicular to oblique.

A relationship between the foliation orientation and the cutting forces can be confirmed as well as a relationship between the penetration and the forces. The rock types with oblique foliation direction seem to have the lowest and those with perpendicular foliation direction most of the time the highest normal forces.

The spacing has an influence on the cutting forces, but it has to be said that the forces do not increase linearly with increasing spacing.

### **5.2 Sieve Analysis**

It turns out that the sieved samples of calcareous mica schist have a higher percentage of fine grains (<1.19 mm) than those of augen gneiss. This may be related with the higher brittleness and lower cutability of augen gneiss. The sieve samples of schistose gneiss contain more fine grains than augen gneiss but less than calcareous mica schist for the spacing-penetration combinations 60-7.6 and 100-7.6. They contain more fine grains than calcareous mica schist for the spacing-penetration combinations 60-5.1 and 80-7.6.

It can be determined that for all rock types the sieved samples became finer grained with a higher percentage of grains having a particle size of <1.19 mm with decreasing spacing.

An apparent influence of the foliation direction on the particle sizes of the sieve samples cannot be seen. Only for calcareous mica schist can it be said

that the sieve samples of the rock cubes with perpendicular foliation direction are always finer grained than the samples from all the other foliation directions.

The influence of the rock type on the particle sizes can be confirmed as well as the influence of the spacing for all rock types and foliation directions, whereas the foliation direction do not seem to have an consistent influence on the grading curves. Augen gneiss has most of the time a coarser grain distribution curve and a lower content of fine grains than calcareous mica schist, which may be a result of the higher brittleness of augen gneiss. Schistose gneiss always has a higher content of fine grains than augen gneiss and sometimes also a higher content than calcareous mica schist.

### **5.3 Specific Energy**

The specific energy decreases with increasing spacing and penetration and usually increases with increasing percentage of fine grains (<1.19 mm).

The influence of the foliation direction on the specific energy can also be confirmed for both calcareous mica schist and augen gneiss. For calcareous mica schist, the specific energy decreases from perpendicular over massive and oblique to parallel foliation direction. For augen gneiss, it decreases from perpendicular over oblique to parallel foliation direction.

### **5.4 Aspect Ratios**

Spacing and penetration show no notable influence on aspect ratios for all rock types and foliation directions, whereas the rock types and foliation directions have an apparent influence on the percentage of non-cubic grains. Calcareous mica schist with parallel and perpendicular foliation direction has a lower percentage of non-cubic grains than with the other foliation directions. In contrast augen gneiss with parallel and perpendicular foliation direction has a higher percentage of non-cubic grains than with oblique foliation direction.

The percentage of non-cubic grains for calcareous mica schist is over 45% for parallel foliation direction, over 50% for perpendicular foliation direction, over 85% for oblique foliation direction, and over 80% for massive rock.

The percentage of non-cubic grains for augen gneiss is over 75% for parallel foliation direction, over 65% for perpendicular foliation direction, over 55% for oblique foliation direction.

The percentage of non-cubic grains for schistose gneiss is over 60% for oblique foliation direction.

## 6 List of Tables

Table 1: Ranges for rock and cutting parameters used in the equations (from [1]) .....	7
Table 2: Factors for the base equation of Gehring (from [4]) .....	11
Table 3: Rock types and the orientations of their foliation to the cutting direction .....	17
Table 4: Average values and standard deviation of rock parameters of calcareous mica schist (modified after [6]) .....	18
Table 5: Average values and standard deviation of rock parameter of augen gneiss (modified after [6]) .....	19
Table 6: Average values and standard deviation of rock parameter of schistose gneiss (modified after [6]) .....	20
Table 7: Cutting program for Block 2 .....	22
Table 8: Cutting program for Block 1 .....	23
Table 9: Cutting program for Block 3 .....	23
Table 10: Cutting program for Block 4 .....	23
Table 11: Average and maximum forces ordered by foliation direction, spacing and penetration for calcareous mica schist.....	30
Table 12: Average and maximum forces ordered by foliation direction, spacing and penetration for augen gneiss.....	32
Table 13: Average and maximum forces ordered by spacing and penetration for schistose gneiss .....	33
Table 14: Specific energy and fine grains for all rock types and foliation directions.....	56
Table 15: Aspect ratios of calcareous mica schist ordered by foliation direction, spacing and penetration.....	59
Table 16: Aspect ratios of augen gneiss ordered by foliation direction, spacing and penetration.....	62
Table 17: Aspect ratios of schistose gneiss ordered by spacing and penetration .....	64

## 7 List of Figures

Figure 1: Breakout process on a single cutter (from [2]) .....	4
Figure 2: Chip formation on a multiple cutter (from [2]) .....	5
Figure 3: Forces on disc cutter (from [2]) .....	5
Figure 4: Geometrical relationship between the penetration and the interacting angle $\varphi$ (from [1]).....	6
Figure 5: Penetration per cutter head revolution by gross thrust per cutter disc (from [3]).....	8
Figure 6: Phases of chip formation (modified after [4]) .....	9
Figure 7: LCM at the EMI, Colorado School of Mines .....	14
Figure 8: (A) LCM layout, (B) three dimensional forces acting on a conical pick cutter, (C) sample nomenclature (from [5]).....	15
Figure 9: Cutter penetration spacers in place.....	16
Figure 10: Cut rock cubes .....	17
Figure 11: Rock cubes of calcareous mica schist with perpendicular, parallel, oblique and massive foliation direction.....	18
Figure 12: Rock cubes of augen gneiss with perpendicular, parallel and oblique foliation direction .....	19
Figure 13: Rock cube of schistose gneiss with oblique foliation direction ..	20
Figure 14: Four boxes with rock cubes.....	21
Figure 15: Rock cubes placed in the metal box lined with plastic sheeting	21
Figure 16: Metal boxes filled with concrete .....	22
Figure 17: Block 1 with 60 mm spacing.....	24
Figure 18: Block 1 with 80 mm spacing.....	25
Figure 19: Block 1 with 100 mm spacing.....	26
Figure 20: Layout of the calibration configuration.....	27
Figure 21: Area between squares for schistose gneiss, series MUL02, pass 08, spacing 60 mm and penetration 7.6 mm .....	29

## 8 List of Diagrams

Diagram 1: Zone of critical cutter thrust for a 17-inch disc cutter (modified after [4]) .....	10
Diagram 2: Penetration $p_{200}$ (for $F_N=200$ kN) as a function of the uniaxial compressive strength (from [4]) .....	11
Diagram 3: Normal, drag and side force of a cut on calcareous mica schist with oblique foliation direction .....	28
Diagram 4: Average normal forces of calcareous mica schist .....	31
Diagram 5: Average normal forces of augen gneiss .....	32
Diagram 6: Average normal forces of schistose gneiss .....	33
Diagram 7: Sieve analysis of all rock types with oblique foliation direction, a spacing of 60 mm and a penetration of 5.1 mm .....	34
Diagram 8: Sieve analysis of calcareous mica schist and augen gneiss with parallel foliation direction, a spacing of 60 mm and a penetration of 5.1 mm .....	35
Diagram 9: Sieve analysis of calcareous mica schist and augen gneiss with perpendicular foliation direction, a spacing of 60 mm and a penetration of 5.1 mm.....	35
Diagram 10: Sieve analysis of all rock types with oblique foliation direction, a spacing of 60 mm and a penetration of 7.6 mm .....	36
Diagram 11: Sieve analysis of calcareous mica schist and augen gneiss with parallel foliation direction, a spacing of 60 mm and a penetration of 7.6 mm .....	36
Diagram 12: Sieve analysis of calcareous mica schist and augen gneiss with perpendicular foliation direction, a spacing of 60 mm and a penetration of 7.6 mm.....	37
Diagram 13: Sieve analysis of all rock types with oblique foliation direction, a spacing of 80 mm and a penetration of 7.6 mm .....	38
Diagram 14: Sieve analysis of calcareous mica schist and augen gneiss with parallel foliation direction, a spacing of 80 mm and a penetration of 7.6 mm .....	38
Diagram 15: Sieve analysis of calcareous mica schist and augen gneiss with perpendicular foliation direction, a spacing of 80 mm and a penetration of 7.6 mm.....	39
Diagram 16: Sieve analysis of all rock types with oblique foliation direction, a spacing of 100 mm and a penetration of 7.6 mm.....	40
Diagram 17: Sieve analysis of calcareous mica schist and augen gneiss with parallel foliation direction, a spacing of 100 mm and a penetration of 7.6 mm .....	40

Diagram 18: Sieve analysis of calcareous mica schist and augen gneiss with perpendicular foliation direction, a spacing of 100 mm and a penetration of 7.6 mm.....	41
Diagram 19: Sieve analysis of calcareous mica schist with a spacing of 60 mm and a penetration of 5.1 mm.....	42
Diagram 20: Sieve analysis of calcareous mica schist with a spacing of 60 mm and a penetration of 7.6 mm.....	43
Diagram 21: Sieve analysis of calcareous mica schist with a spacing of 80 mm and a penetration 7.6 mm .....	44
Diagram 22: Sieve analysis of calcareous mica schist with a spacing of 100 mm and a penetration of 7.6 mm.....	45
Diagram 23: Sieve analysis of calcareous mica schist with massive foliation .....	46
Diagram 24: Sieve analysis of calcareous mica schist with oblique foliation direction .....	46
Diagram 25: Sieve analysis of calcareous mica schist with parallel foliation direction .....	47
Diagram 26: Sieve analysis of calcareous mica schist with perpendicular foliation direction .....	48
Diagram 27: Sieve analysis of augen gneiss with a spacing of 60 mm and a penetration of 5.1 mm.....	49
Diagram 28: Sieve analysis of augen gneiss with a spacing of 80 mm and a penetration of 7.6 mm.....	50
Diagram 29: Sieve analysis of augen gneiss with a spacing of 80 mm and a penetration of 7.6 mm.....	50
Diagram 30: Sieve analysis of augen gneiss with a spacing of 100 mm and a penetration of 7.6 mm .....	51
Diagram 31: Sieve analysis of augen gneiss with oblique foliation direction .....	52
Diagram 32: Sieve analysis of augen gneiss with parallel foliation direction .....	52
Diagram 33: Sieve analysis of augen gneiss with perpendicular foliation direction .....	53
Diagram 34: Sieve analysis of oblique schistose gneiss with a spacing-penetration combination .....	54
Diagram 35: Specific energy by spacing-penetration ratio for all rock types .....	55
Diagram 36: Specific energy by the percentage of grains with a particle size <1.19 mm for all rock types .....	55
Diagram 37: Aspect ratio diagram.....	58

Diagram 38: Aspect ratios of sample KGSm-P6-C7+8-60-5 by particle size .....	60
Diagram 39: Aspect ratios of sample KGSm-P7-C7+8-60-7.5 by particle size .....	60
Diagram 40: Aspect ratios of sample KGSm-P13-C6-80-7.5 by particle size .....	61
Diagram 41: Aspect ratios of sample KGSm-P20-C6-100-7.5 by particle size .....	61
Diagram 42: Aspect ratios of sample AGper-P3-C7+8-60-5 by particle size .....	62
Diagram 43: Aspect ratios of sample AGper-P9-C7+8-60-7.5 by particle size .....	63
Diagram 44: Aspect ratios of sample AGper-P13-C6-80-7.5 by particle size .....	63
Diagram 45: Aspect ratios of sample AGper-P20-C6-100-7.5 by particle size .....	64
Diagram 46: Aspect ratios of sample SGo-P3-C2+3-60-5 by particle size .	65
Diagram 47: Aspect ratios of sample SGo-P7-C2+3-60-7.5 by particle size .....	65
Diagram 48: Aspect ratios of sample SGo-P13-C2-80-7.5 by particle size.	66
Diagram 49: Aspect ratios of sample SGo-P20-C2-100-7.5 by particle size	66



## 9 Bibliography

- [1] Rostami J., Ozdemir L. (1993): *A New Model for Performance Prediction of Hard Rock TBMs*. Rapid Excavation and Tunneling Conference (RETC) Proceedings 1993; Boston; pp 793-809
- [2] Ozdemir L.: *CSM Computer Model for TBM Performance Prediction*. [http://emi.mines.edu/papers/seminar/08\\_02\\_machine\\_performance\\_assessment\\_and\\_costing.pdf](http://emi.mines.edu/papers/seminar/08_02_machine_performance_assessment_and_costing.pdf); 25.03.2012
- [3] Amund B. (1998): *Hard Rock Tunnel Boring*. Doctor thesis at NTNU
- [4] Gehring K. (1995): *Leistungs- und Verschleißprognosen im maschinellen Tunnelbau*. Felsbau 13 (1995) Nr. 6; pp 439-448
- [5] Cigla M., Ozdemir L. (2000): *Computer Modeling For Improved Production of Mechanical Excavators*. Society for Mining, Metallurgy and Exploration (SME) Annual Meeting 2000; Salt Lake City
- [6] Lassnig K., Entacher M., Biermeier F., Galler R., Ebner F. (2012): *Decrease of Schmidt hammer hardness controlled by schistosity orientation of metamorphic rocks after loading with TBM disc cutters*. Int J Rock Mech Min Sci 2012; under review

## Appendix A – Sieve Analysis

The following tables contain the results of the sieve analysis of the individual sieve samples. They are ordered by rock type, foliation direction, and spacing-penetration combination.

### Calcareous Mica Schist

	Pass 3	Pass 4	Pass 5	Pass 6	Average
Sieve Size	Cumulative passed	Cumulative passed	Cumulative passed	Cumulative passed	Cumulative passed
mm	%	%	%	%	%
88.90	100.00	100.00	100.00	100.00	100.00
45.00	100.00	100.00	100.00	100.00	100.00
32.00	100.00	93.18	72.97	91.20	89.34
16.00	64.36	57.06	62.85	63.21	61.87
9.51	46.43	50.83	52.45	48.59	49.58
4.00	38.94	37.51	39.29	35.65	37.85
2.00	30.58	28.71	30.68	27.26	29.31
1.19	26.49	24.73	26.61	23.39	25.31
0.00	0.00	0.00	0.00	0.00	0.00

**Foliation direction: parallel, spacing: 60 mm, penetration: 5.1 mm**

	Pass 7	Pass 8	Pass 9	Pass 10	Average
Sieve Size	Cumulative passed	Cumulative passed	Cumulative passed	Cumulative passed	Cumulative passed
mm	%	%	%	%	%
88.90	100.00	100.00	100.00	100.00	100.00
45.00	100.00	100.00	100.00	100.00	100.00
32.00	84.98	94.85	100.00	100.00	94.96
16.00	58.66	67.90	75.59	71.31	68.36
9.51	49.12	55.63	60.65	60.94	56.59
4.00	35.46	39.80	43.60	44.04	40.73
2.00	27.56	30.77	34.09	35.08	31.87
1.19	23.83	26.56	29.66	30.60	27.66
0.00	0.00	0.00	0.00	0.00	0.00

**Foliation direction: parallel, spacing: 60 mm, penetration: 7.6 mm**

	Pass 13	Pass 14	Pass 15	Pass 16	Average
Sieve Size	Cumulative passed	Cumulative passed	Cumulative passed	Cumulative passed	Cumulative passed
mm	%	%	%	%	%
88.90	100.00	100.00	100.00	100.00	100.00
45.00	86.09	100.00	78.68	74.43	84.80
32.00	79.40	82.40	78.68	74.43	78.73
16.00	60.66	59.85	62.77	58.45	60.43
9.51	46.63	44.89	48.33	49.51	47.34
4.00	33.65	30.91	31.86	35.06	32.87
2.00	26.05	23.40	23.88	27.49	25.20
1.19	22.39	20.00	20.44	24.06	21.72
0.00	0.00	0.00	0.00	0.00	0.00

**Foliation direction: parallel, spacing: 80 mm, penetration: 7.6 mm**

	Pass 19	Pass 20	Pass 21	Pass 22	Average
Sieve Size	Cumulative passed	Cumulative passed	Cumulative passed	Cumulative passed	Cumulative passed
mm	%	%	%	%	%
88.90	100.00	100.00	100.00	100.00	100.00
45.00	56.46	44.69	78.25	75.50	63.73
32.00	49.26	39.55	73.09	55.42	54.33
16.00	41.09	23.50	55.41	52.18	43.05
9.51	31.64	18.15	43.93	41.11	33.71
4.00	20.92	13.32	31.50	29.80	23.89
2.00	15.24	10.63	24.85	23.24	18.49
1.19	13.11	9.42	21.91	20.15	16.15
0.00	0.00	0.00	0.00	0.00	0.00

**Foliation direction: parallel, spacing: 100 mm, penetration: 7.6 mm**

	Pass 3	Pass 4	Pass 5	Pass 6	Average
Sieve Size	Cumulative passed	Cumulative passed	Cumulative passed	Cumulative passed	Cumulative passed
mm	%	%	%	%	%
88.90	100.00	100.00	100.00	100.00	100.00
45.00	100.00	100.00	100.00	100.00	100.00
32.00	100.00	100.00	94.77	100.00	98.69
16.00	83.77	84.68	83.56	84.59	84.15
9.51	68.24	66.89	66.05	62.88	66.02
4.00	44.87	44.33	46.87	42.62	44.67
2.00	33.72	34.57	37.04	33.16	34.62
1.19	29.10	30.18	32.59	29.15	30.26
0.00	0.00	0.00	0.00	0.00	0.00

**Foliation direction: perpendicular, spacing: 60 mm, penetration: 5.1 mm**

	Pass 7	Pass 8	Pass 9	Pass 10	Average
Sieve Size	Cumulative passed	Cumulative passed	Cumulative passed	Cumulative passed	Cumulative passed
mm	%	%	%	%	%
88.90	100.00	100.00	100.00	100.00	100.00
45.00	100.00	100.00	100.00	100.00	100.00
32.00	100.00	96.82	100.00	97.30	98.53
16.00	87.31	82.76	84.35	83.02	84.36
9.51	67.10	61.03	68.10	64.62	65.21
4.00	46.03	41.17	46.46	43.78	44.36
2.00	36.31	31.80	36.33	34.33	34.69
1.19	31.82	27.78	32.02	30.06	30.42
0.00	0.00	0.00	0.00	0.00	0.00

**Foliation direction: perpendicular, spacing: 60 mm, penetration: 7.6 mm**

	Pass 13	Pass 14	Pass 15	Pass 16	Average
Sieve Size	Cumulative passed	Cumulative passed	Cumulative passed	Cumulative passed	Cumulative passed
mm	%	%	%	%	%
88.90	100.00	100.00	100.00	100.00	100.00
45.00	100.00	100.00	100.00	100.00	100.00
32.00	94.25	93.27	92.43	100.00	94.99
16.00	75.34	73.63	62.39	62.84	68.55
9.51	60.49	55.00	49.97	41.41	51.72
4.00	40.87	35.13	34.35	28.98	34.83
2.00	32.07	27.25	27.26	22.66	27.31
1.19	28.11	23.87	23.97	19.74	23.92
0.00	0.00	0.00	0.00	0.00	0.00

**Foliation direction: perpendicular, spacing: 80 mm, penetration: 7.6 mm**

	Pass 19	Pass 20	Pass 21	Pass 22	Average
Sieve Size	Cumulative passed	Cumulative passed	Cumulative passed	Cumulative passed	Cumulative passed
mm	%	%	%	%	%
88.90	100.00	100.00	100.00	100.00	100.00
45.00	100.00	92.20	100.00	100.00	98.05
32.00	79.63	73.24	100.00	100.00	88.22
16.00	50.51	47.08	64.82	63.97	56.60
9.51	37.31	34.09	48.40	45.75	41.39
4.00	24.02	22.16	33.79	32.73	28.18
2.00	18.59	17.46	27.01	26.30	22.34
1.19	16.29	15.35	23.81	23.35	19.70
0.00	0.00	0.00	0.00	0.00	0.00

**Foliation direction: perpendicular, spacing: 100 mm, penetration: 7.6 mm**

	Pass 3	Pass 4	Pass 5	Pass 6	Average
Sieve Size	Cumulative passed	Cumulative passed	Cumulative passed	Cumulative passed	Cumulative passed
mm	%	%	%	%	%
88.90	100.00	100.00	100.00	100.00	100.00
45.00	100.00	100.00	100.00	100.00	100.00
32.00	96.88	85.13	90.78	80.78	88.39
16.00	78.11	69.15	71.91	59.05	69.55
9.51	67.06	53.40	59.34	47.41	56.80
4.00	46.41	37.47	42.51	33.00	39.85
2.00	35.43	29.24	32.81	25.88	30.84
1.19	30.69	25.43	28.49	22.68	26.82
0.00	0.00	0.00	0.00	0.00	0.00

**Foliation direction: oblique, spacing: 60 mm, penetration: 5.1 mm**

	Pass 7	Pass 8	Pass 9	Pass 10	Average
Sieve Size	Cumulative passed	Cumulative passed	Cumulative passed	Cumulative passed	Cumulative passed
mm	%	%	%	%	%
88.90	100.00	100.00	100.00	100.00	100.00
45.00	100.00	100.00	100.00	100.00	100.00
32.00	86.16	96.71	83.42	81.14	86.86
16.00	72.33	73.79	65.24	61.67	68.26
9.51	56.47	59.89	51.48	49.66	54.37
4.00	40.67	43.97	36.76	35.67	39.27
2.00	31.68	34.65	28.20	27.71	30.56
1.19	27.51	30.17	24.39	24.07	26.54
0.00	0.00	0.00	0.00	0.00	0.00

**Foliation direction: oblique, spacing: 60 mm, penetration: 7.6 mm**

	Pass 13	Pass 14	Pass 15	Pass 16	Average
Sieve Size	Cumulative passed	Cumulative passed	Cumulative passed	Cumulative passed	Cumulative passed
mm	%	%	%	%	%
88.90	100.00	100.00	100.00	100.00	100.00
45.00	100.00	89.25	72.97	100.00	90.55
32.00	63.94	54.62	59.94	76.31	63.70
16.00	52.75	46.73	47.37	49.99	49.21
9.51	44.44	36.64	38.99	40.52	40.15
4.00	32.86	25.84	28.33	28.57	28.90
2.00	26.10	20.02	22.01	21.85	22.50
1.19	22.89	17.39	18.91	18.73	19.48
0.00	0.00	0.00	0.00	0.00	0.00

**Foliation direction: oblique, spacing: 80 mm, penetration: 7.6 mm**

	P19	P20	P21	P22	Average
Sieve Size	Cumulative passed	Cumulative passed	Cumulative passed	Cumulative passed	Cumulative passed
mm	%	%	%	%	%
88.90	100.00	100.00	100.00	100.00	100.00
45.00	49.04	76.39	100.00	74.56	75.00
32.00	33.27	55.98	91.07	58.90	59.80
16.00	27.31	42.90	69.06	48.48	46.94
9.51	22.51	36.73	54.61	40.38	38.56
4.00	16.25	27.59	41.46	30.10	28.85
2.00	12.74	21.99	32.17	23.79	22.67
1.19	11.18	19.27	27.84	20.87	19.79
0.00	0.00	0.00	0.00	0.00	0.00

**Foliation direction: oblique, spacing: 100 mm, penetration: 7.6 mm**

	Pass 2	Pass 3	Pass 4	Pass 5	Pass 6	Average
Sieve Size	Cumulative passed	Cumulative passed	Cumulative passed	Cumulative passed	Cumulative passed	Cumulative passed
mm	%	%	%	%	%	%
88.90	100.00	100.00	100.00	100.00	100.00	100.00
45.00	100.00	100.00	84.98	100.00	100.00	97.00
32.00	86.88	95.31	75.25	100.00	85.79	88.65
16.00	73.18	74.32	53.58	67.85	70.90	67.97
9.51	59.18	58.26	43.01	52.97	54.54	53.59
4.00	39.26	41.85	29.47	36.81	38.76	37.23
2.00	29.93	32.47	22.72	28.78	30.10	28.80
1.19	25.49	27.99	19.69	24.90	26.18	24.85
0.00	0.00	0.00	0.00	0.00	0.00	0.00

**Foliation direction: massive, spacing: 60 mm, penetration: 5.1 mm**

	Pass 7	Pass 8	Pass 9	Pass 10	Average
Sieve Size	Cumulative passed	Cumulative passed	Cumulative passed	Cumulative passed	Cumulative passed
mm	%	%	%	%	%
88.90	100.00	100.00	100.00	100.00	100.00
45.00	90.20	100.00	100.00	100.00	97.55
32.00	85.21	87.73	90.91	92.21	89.01
16.00	59.28	68.06	62.97	66.36	64.17
9.51	45.44	52.51	48.88	53.34	50.04
4.00	30.95	37.20	33.02	36.90	34.52
2.00	23.78	28.88	25.46	28.46	26.64
1.19	20.57	24.85	21.93	24.46	22.95
0.00	0.00	0.00	0.00	0.00	0.00

**Foliation direction: massive, spacing: 60 mm, penetration: 7.6 mm**

	Pass 13	Pass 14	Pass 15	Pass 17	Average
Sieve Size	Cumulative passed	Cumulative passed	Cumulative passed	Cumulative passed	Cumulative passed
mm	%	%	%	%	%
88.90	100.00	100.00	100.00	100.00	100.00
45.00	100.00	86.41	100.00	100.00	96.60
32.00	80.13	77.89	92.63	100.00	87.66
16.00	51.93	51.53	54.10	72.62	57.55
9.51	41.37	39.65	39.43	49.07	42.38
4.00	30.40	27.44	28.75	32.23	29.70
2.00	24.09	21.15	22.68	24.38	23.08
1.19	20.97	18.25	19.47	20.82	19.88
0.00	0.00	0.00	0.00	0.00	0.00

**Foliation direction: massive, spacing: 80 mm, penetration: 7.6 mm**

	Pass 20	Pass 21	Average
Sieve Size	Cumulative passed	Cumulative passed	Cumulative passed
mm	%	%	%
88.90	100.00	100.00	100.00
45.00	46.38	53.31	49.85
32.00	46.38	36.90	41.64
16.00	32.74	27.18	29.96
9.51	25.08	19.82	22.45
4.00	17.52	14.12	15.82
2.00	13.51	10.78	12.14
1.19	11.69	9.26	10.47
0.00	0.00	0.00	0.00

**Foliation direction: massive, spacing: 100 mm, penetration: 7.6 mm**

## Augen Gneiss

	Pass 3	Pass 4	Pass 5	Pass 6	Average
Sieve Size	Cumulative passed	Cumulative passed	Cumulative passed	Cumulative passed	Cumulative passed
mm	%	%	%	%	%
88.90	100.00	100.00	100.00	100.00	100.00
45.00	89.19	100.00	100.00	100.00	97.30
32.00	65.61	70.42	100.00	90.46	81.62
16.00	42.99	39.68	67.07	54.92	51.16
9.51	31.47	32.65	44.78	42.45	37.84
4.00	20.12	22.18	30.47	30.69	25.86
2.00	14.78	16.60	22.74	23.69	19.45
1.19	12.30	13.84	19.15	19.95	16.31
0.00	0.00	0.00	0.00	0.00	0.00

**Foliation direction: parallel, spacing: 60 mm, penetration: 5.1 mm**

	Pass 7	Pass 8	Pass 9	Pass 10	Average
Sieve Size	Cumulative passed	Cumulative passed	Cumulative passed	Cumulative passed	Cumulative passed
mm	%	%	%	%	%
88.90	100.00	100.00	100.00	100.00	100.00
45.00	100.00	100.00	100.00	100.00	100.00
32.00	76.63	100.00	85.67	95.04	89.33
16.00	54.72	67.47	54.63	59.63	59.11
9.51	41.26	53.20	39.58	43.90	44.49
4.00	28.77	38.32	26.42	30.00	30.88
2.00	21.84	29.14	19.72	22.41	23.28
1.19	18.40	24.73	16.40	18.75	19.57
0.00	0.00	0.00	0.00	0.00	0.00

**Foliation direction: parallel, spacing: 60 mm, penetration: 7.6 mm**

	Pass 13	Pass 14	Pass 15	Pass 16	Average
Sieve Size	Cumulative passed	Cumulative passed	Cumulative passed	Cumulative passed	Cumulative passed
mm	%	%	%	%	%
88.90	100.00	100.00	100.00	100.00	100.00
45.00	100.00	80.45	90.61	100.00	92.77
32.00	73.70	73.11	71.43	79.08	74.33
16.00	56.23	48.52	48.74	53.59	51.77
9.51	45.18	35.19	36.26	40.65	39.32
4.00	30.29	26.00	25.35	31.80	28.36
2.00	23.11	20.28	19.23	24.98	21.90
1.19	19.60	17.19	16.27	21.53	18.65
0.00	0.00	0.00	0.00	0.00	0.00

**Foliation direction: parallel, spacing: 80 mm, penetration: 7.6 mm**

	Pass 19	Pass 20	Pass 21	Pass 22	Average
Sieve Size	Cumulative passed	Cumulative passed	Cumulative passed	Cumulative passed	Cumulative passed
mm	%	%	%	%	%
88.90	100.00	100.00	100.00	100.00	100.00
45.00	87.87	71.31	66.42	82.46	77.01
32.00	70.75	59.03	51.63	58.54	59.99
16.00	37.66	41.24	39.19	41.36	39.86
9.51	26.23	31.37	29.10	33.85	30.14
4.00	17.61	21.52	19.77	24.93	20.96
2.00	13.97	16.60	15.20	19.48	16.31
1.19	11.96	14.20	12.79	16.61	13.89
0.00	0.00	0.00	0.00	0.00	0.00

**Foliation direction: parallel, spacing: 100 mm, penetration: 7.6 mm**

	Pass 3	Pass 4	Pass 5	Pass 6	Average
Sieve Size	Cumulative passed	Cumulative passed	Cumulative passed	Cumulative passed	Cumulative passed
mm	%	%	%	%	%
88.90	100.00	100.00	100.00	100.00	100.00
45.00	100.00	100.00	100.00	100.00	100.00
32.00	72.36	94.40	89.87	100.00	89.16
16.00	45.39	58.02	64.78	67.38	58.89
9.51	35.14	48.67	50.71	52.55	46.77
4.00	24.04	34.72	34.10	36.88	32.43
2.00	18.29	26.62	25.37	27.95	24.56
1.19	15.45	22.52	21.23	23.70	20.73
0.00	0.00	0.00	0.00	0.00	0.00

**Foliation direction: perpendicular, spacing: 60 mm, penetration: 5.1 mm**

	Pass 7	Pass 8	Pass 9	Pass 10	Average
Sieve Size	Cumulative passed	Cumulative passed	Cumulative passed	Cumulative passed	Cumulative passed
mm	%	%	%	%	%
88.90	100.00	100.00	100.00	100.00	100.00
45.00	100.00	100.00	100.00	100.00	100.00
32.00	93.46	100.00	96.91	89.46	94.96
16.00	69.12	72.79	68.45	62.42	68.20
9.51	48.04	55.47	53.49	46.75	50.94
4.00	32.03	35.20	35.46	31.98	33.67
2.00	23.32	25.35	26.10	23.31	24.52
1.19	19.42	21.15	21.72	19.33	20.41
0.00	0.00	0.00	0.00	0.00	0.00

**Foliation direction: perpendicular, spacing: 60 mm, penetration: 7.6 mm**

	Pass 13	Pass 14	Pass 15	Pass 16	Average
Sieve Size	Cumulative passed	Cumulative passed	Cumulative passed	Cumulative passed	Cumulative passed
mm	%	%	%	%	%
88.90	100.00	100.00	100.00	100.00	100.00
45.00	90.03	100.00	100.00	92.10	95.53
32.00	73.96	90.90	78.38	69.16	78.10
16.00	59.64	53.63	66.53	40.69	55.12
9.51	39.14	39.46	48.26	27.23	38.52
4.00	26.08	25.36	34.69	19.32	26.36
2.00	19.11	19.24	27.11	14.26	19.93
1.19	15.88	16.15	23.29	12.00	16.83
0.00	0.00	0.00	0.00	0.00	0.00

**Foliation direction: perpendicular, spacing: 80 mm, penetration: 7.6 mm**

	Pass 19	Pass 20	Pass 21	Pass 22	Average
Sieve Size	Cumulative passed	Cumulative passed	Cumulative passed	Cumulative passed	Cumulative passed
mm	%	%	%	%	%
88.90	100.00	100.00	100.00	100.00	100.00
45.00	100.00	55.40	77.69	89.35	80.61
32.00	85.51	52.57	64.83	64.50	66.85
16.00	51.15	31.25	39.79	36.43	39.65
9.51	33.39	22.26	26.93	27.88	27.61
4.00	21.46	14.68	16.80	18.70	17.91
2.00	16.17	10.79	12.59	14.37	13.48
1.19	13.67	9.03	10.60	12.20	11.37
0.00	0.00	0.00	0.00	0.00	0.00

**Foliation direction: perpendicular, spacing: 100 mm, penetration: 7.6 mm**

	Pass 3	Pass 4	Pass 5	Pass 6	Average
Sieve Size	Cumulative passed	Cumulative passed	Cumulative passed	Cumulative passed	Cumulative passed
mm	%	%	%	%	%
88.90	100.00	100.00	100.00	100.00	100.00
45.00	100.00	100.00	100.00	100.00	100.00
32.00	100.00	94.69	97.54	88.41	95.16
16.00	69.78	75.23	70.56	61.31	69.22
9.51	51.38	58.32	53.11	45.29	52.02
4.00	33.79	39.98	35.05	29.60	34.61
2.00	24.71	29.68	25.51	21.45	25.33
1.19	20.58	24.85	8.97	17.65	18.01
0.00	0.00	0.00	0.00	0.00	0.00

**Foliation direction: oblique, spacing: 60 mm, penetration: 5.1 mm**

	Pass 7	Pass 8	Pass 9	Pass 10	Average
Sieve Size	Cumulative passed	Cumulative passed	Cumulative passed	Cumulative passed	Cumulative passed
mm	%	%	%	%	%
88.90	100.00	100.00	100.00	100.00	100.00
45.00	100.00	100.00	100.00	100.00	100.00
32.00	82.10	100.00	95.85	90.58	92.13
16.00	62.85	77.74	72.18	62.88	68.91
9.51	46.13	58.86	54.59	48.61	52.04
4.00	30.74	38.66	36.86	32.32	34.64
2.00	22.34	28.29	27.11	24.04	25.45
1.19	18.46	23.39	22.60	20.13	21.14
0.00	0.00	0.00	0.00	0.00	0.00

**Foliation direction: oblique, spacing: 60 mm, penetration: 7.6 mm**

	Pass 13	Pass 14	Pass 15	Pass 16	Average
Sieve Size	Cumulative passed	Cumulative passed	Cumulative passed	Cumulative passed	Cumulative passed
mm	%	%	%	%	%
88.90	100.00	100.00	100.00	100.00	100.00
45.00	100.00	73.06	100.00	77.65	87.68
32.00	90.58	62.64	77.99	66.45	74.42
16.00	62.88	48.44	50.74	51.51	53.39
9.51	48.61	37.61	38.53	40.43	41.29
4.00	32.32	26.01	24.18	29.12	27.91
2.00	24.04	19.78	17.51	22.18	20.88
1.19	20.13	16.75	14.46	18.55	17.47
0.00	0.00	0.00	0.00	0.00	0.00

**Foliation direction: oblique, spacing: 80 mm, penetration: 7.6 mm**



	Pass 19	Pass 20	Pass 21	Pass 22	Average
Sieve Size	Cumulative passed	Cumulative passed	Cumulative passed	Cumulative passed	Cumulative passed
mm	%	%	%	%	%
88.90	100.00	100.00	100.00	100.00	100.00
45.00	81.78	50.40	100.00	79.44	77.90
32.00	72.96	45.90	71.61	69.76	65.06
16.00	51.81	32.46	45.90	41.17	42.83
9.51	34.37	22.80	35.41	27.71	30.07
4.00	23.00	15.36	24.70	18.22	20.32
2.00	17.20	11.53	19.23	13.54	15.37
1.19	14.50	9.67	16.53	11.40	13.02
0.00	0.00	0.00	0.00	0.00	0.00

**Foliation direction: oblique, spacing: 100 mm, penetration: 7.6 mm**

### Schistose Gneiss

	Pass 2	Pass 3	Pass 4	Pass 5	Pass 6	Average
Sieve Size	Cumulative passed	Cumulative passed	Cumulative passed	Cumulative passed	Cumulative passed	Cumulative passed
mm	%	%	%	%	%	%
88.90	100.00	100.00	100.00	100.00	100.00	100.00
45.00	100.00	100.00	100.00	100.00	100.00	100.00
32.00	89.29	100.00	92.13	85.67	93.46	92.11
16.00	64.96	69.36	69.18	62.77	71.35	67.52
9.51	41.33	57.01	58.16	52.71	59.02	53.64
4.00	28.45	44.50	45.22	43.26	46.89	41.66
2.00	22.75	37.71	38.27	36.87	39.30	34.98
1.19	19.99	33.71	34.19	32.82	34.92	31.13
0.00	0.00	0.00	0.00	0.00	0.00	0.00

**Foliation direction: oblique, spacing: 60 mm, penetration: 5.1 mm**

	Pass 7	Pass 8	Pass 9	Pass 10	Average
Sieve Size	Cumulative passed	Cumulative passed	Cumulative passed	Cumulative passed	Cumulative passed
mm	%	%	%	%	%
88.90	100.00	100.00	100.00	100.00	100.00
45.00	100.00	100.00	73.17	100.00	93.29
32.00	83.49	85.52	65.13	86.47	80.15
16.00	58.79	59.85	47.10	58.47	56.05
9.51	49.97	45.35	37.94	45.71	44.74
4.00	37.63	35.39	29.11	35.46	34.40
2.00	31.08	29.28	24.09	29.26	28.42
1.19	27.47	25.79	21.33	25.73	25.08
0.00	0.00	0.00	0.00	0.00	0.00

**Foliation direction: oblique, spacing: 60 mm, penetration: 7.6 mm**

	Pass 13	Pass 14	Pass 15	Pass 16	Pass 17	Average
Sieve Size	Cumulative passed	Cumulative passed	Cumulative passed	Cumulative passed	Cumulative passed	Cumulative passed
mm	%	%	%	%	%	%
88.90	100.00	100.00	100.00	100.00	100.00	100.00
45.00	86.90	88.60	61.70	75.91	59.07	74.43
32.00	76.70	75.18	57.44	75.91	51.81	67.41
16.00	54.58	54.43	46.70	47.86	47.39	50.19
9.51	46.89	42.40	36.61	37.57	38.00	40.29
4.00	36.27	31.95	28.45	28.83	30.18	31.14
2.00	30.04	26.30	23.78	24.13	25.02	25.85
1.19	26.54	23.32	20.96	21.48	22.05	22.87
0.00	0.00	0.00	0.00	0.00	0.00	0.00

**Foliation direction: oblique, spacing: 80 mm, penetration: 7.6 mm**

Sieve Size	Pass 20	Pass 21	Average
mm	Cumulative passed	Cumulative passed	Cumulative passed
	%	%	%
88.90	100.00	100.00	100.00
45.00	57.47	67.85	62.66
32.00	57.47	48.29	52.88
16.00	42.08	32.38	37.23
9.51	33.98	24.46	29.22
4.00	26.73	18.07	22.40
2.00	22.23	14.58	18.41
1.19	19.63	12.80	16.22
0.00	0.00	0.00	0.00

**Foliation direction: oblique, spacing: 100 mm, penetration: 7.6 mm**

**Appendix B- Aspect Ratios** The following tables show the results of aspect ratio analysis ordered by rock type, foliation direction, pass, spacing and penetration. They include the mass of cubic and non-cubic grains as well as their percentage for each measured sieve size.

### Calcareous Mica Schist

Sieve Size	Mass cubic	Percentage cubic	Mass non-cubic	Percentage non-cubic
mm	g	M-%	g	M-%
16	33.39	85.44	5.69	14.56
9,51	3.91	19.87	15.77	80.13
gesamt	37.3	63.48	21.46	36.52

**Foliation direction: parallel, pass: 3, spacing: 60 mm, penetration: 5.1 mm**

Sieve Size	Mass cubic	Percentage cubic	Mass non-cubic	Percentage non-cubic
mm	g	M-%	g	M-%
32	0	0.00	45.1	100.00
16	19.1	8.03	218.72	91.97
9.51	9.74	23.65	31.44	76.35
gesamt	28.84	8.90	295.26	91.10

**Foliation direction: parallel, pass: 4, spacing: 60 mm, penetration: 5.1 mm**

Sieve Size	Mass cubic	Percentage cubic	Mass non-cubic	Percentage non-cubic
mm	g	M-%	g	M-%
32	50.62	18.73	219.61	81.27
16	10.8	10.74	89.73	89.26
9.51	12.07	21.15	45	78.85
gesamt	73.49	17.18	354.34	82.82

**Foliation direction: parallel, pass: 5, spacing: 60 mm, penetration: 5.1 mm**

Sieve Size	Mass cubic	Percentage cubic	Mass non-cubic	Percentage non-cubic
mm	g	M-%	g	M-%
32	47.77	57.69	35.04	42.31
16	118.93	45.16	144.45	54.84
9.51	34.65	46.97	39.12	53.03
gesamt	201.35	47.95	218.61	52.05

**Foliation direction: parallel, pass: 6, spacing: 60 mm, penetration: 5.1 mm**

Sieve Size	Mass cubic	Percentage cubic	Mass non-cubic	Percentage non-cubic
mm	g	M-%	g	M-%
32	0	0.00	251.45	100.00
16	177.98	49.22	183.59	50.78
9.51	45.19	44.56	56.22	55.44
gesamt	223.17	31.24	491.26	68.76

**Foliation direction: parallel, pass: 7, spacing: 60 mm, penetration: 7.6 mm**

Sieve	Mass	Percentage	Mass	Percentage
-------	------	------------	------	------------

Size	cubic	cubic	non-cubic	non-cubic
mm	g	M-%	g	M-%
32	0	0.00	68.53	100.00
16	310.28	86.04	50.35	13.96
9.51	30.24	37.50	50.39	62.50
gesamt	340.52	66.80	169.27	33.20

**Foliation direction: parallel, pass: 8, spacing: 60 mm, penetration: 7.6 mm**

Sieve Size	Mass cubic	Percentage cubic	Mass non-cubic	Percentage non-cubic
mm	g	M-%	g	M-%
16	145.56	44.36	182.59	55.64
9.51	48.89	55.98	38.45	44.02
gesamt	194.45	46.80	221.04	53.20

**Foliation direction: parallel, pass: 9, spacing: 60 mm, penetration: 7.6 mm**

Sieve Size	Mass cubic	Percentage cubic	Mass non-cubic	Percentage non-cubic
mm	g	M-%	g	M-%
16	161.72	43.98	206.01	56.02
9.51	35.48	40.71	51.67	59.29
gesamt	197.2	43.35	257.68	56.65

**Foliation direction: parallel, pass: 10, spacing: 60 mm, penetration: 7.6 mm**

Sieve Size	Mass cubic	Percentage cubic	Mass non-cubic	Percentage non-cubic
mm	g	M-%	g	M-%
45	0	0.00	112.64	100.00
32	0	0.00	54.23	100.00
16	114.01	75.05	37.91	24.95
9.51	45.46	53.71	39.18	46.29
gesamt	159.47	39.53	243.96	60.47

**Foliation direction: parallel, pass: 13, spacing: 80 mm, penetration: 7.6 mm**

Sieve Size	Mass cubic	Percentage cubic	Mass non-cubic	Percentage non-cubic
mm	g	M-%	g	M-%
32	88.21	100.00	0	0.00
16	69.66	28.93	171.14	71.07
9.51	45.49	52.26	41.55	47.74
gesamt	203.36	48.88	212.69	51.12

**Foliation direction: parallel, pass: 14, spacing: 80 mm, penetration: 7.6 mm**

Sieve Size	Mass cubic	Percentage cubic	Mass non-cubic	Percentage non-cubic
mm	g	M-%	g	M-%
45	0	0.00	145.09	100.00
16	52.29	33.03	106	66.97
9.51	46.49	57.22	34.76	42.78
gesamt	98.78	25.68	285.85	74.32

**Foliation direction: parallel, pass: 15, spacing: 80 mm, penetration: 7.6 mm**

Sieve	Mass	Percentage	Mass	Percentage
-------	------	------------	------	------------

Size	cubic	cubic	non-cubic	non-cubic
mm	g	M-%	g	M-%
32	207.16	100.00	0	0.00
16	57.05	44.11	72.29	55.89
9.51	25.3	39.32	39.05	60.68
gesamt	289.51	72.22	111.34	27.78

**Foliation direction: parallel, pass: 16, spacing: 80 mm, penetration: 7.6 mm**

Sieve Size	Mass cubic	Percentage cubic	Mass non-cubic	Percentage non-cubic
mm	g	M-%	g	M-%
45	0	0.00	632.15	100.00
32	104.58	100.00	0	0.00
16	48	40.70	69.95	59.30
9.51	30.2	44.61	37.5	55.39
gesamt	182.78	19.82	739.6	80.18

**Foliation direction: parallel, pass: 19, spacing: 100 mm, penetration: 7.6 mm**

Sieve Size	Mass cubic	Percentage cubic	Mass non-cubic	Percentage non-cubic
mm	g	M-%	g	M-%
45	1826	100.00	0	0.00
32	128.38	75.74	41.12	24.26
16	269.99	50.97	259.72	49.03
9.51	57.07	69.44	25.12	30.56
gesamt	2281.44	87.50	325.96	12.50

**Foliation direction: parallel, pass: 20, spacing: 100 mm, penetration: 7.6 mm**

Sieve Size	Mass cubic	Percentage cubic	Mass non-cubic	Percentage non-cubic
mm	g	M-%	g	M-%
45	0	0.00	201.74	100.00
32	0	0.00	47.78	100.00
16	43.41	26.53	120.2	73.47
9.51	22.79	32.90	46.49	67.10
gesamt	66.2	13.72	416.21	86.28

**Foliation direction: parallel, pass: 21, spacing: 100 mm, penetration: 7.6 mm**

Sieve Size	Mass cubic	Percentage cubic	Mass non-cubic	Percentage non-cubic
mm	g	M-%	g	M-%
45	165.65	100.00	0	0.00
32	135.83	100.00	0	0.00
16	21.95	100.00	0	0.00
9.51	53.06	73.36	19.27	26.64
gesamt	376.49	95.13	19.27	4.87

**Foliation direction: parallel, pass: 22, spacing: 100 mm, penetration: 7.6 mm**

Sieve Size	Mass cubic	Percentage cubic	Mass non-cubic	Percentage non-cubic
mm	g	M-%	g	M-%
16	50.71	32.53	105.19	67.47
9.51	12.35	19.47	51.07	80.53
gesamt	63.06	28.75	156.26	71.25

**Foliation direction: perpendicular, pass: 3, spacing: 60 mm, penetration: 5.1 mm**

Sieve Size	Mass cubic	Percentage cubic	Mass non-cubic	Percentage non-cubic
mm	g	M-%	g	M-%
16	46.14	27.71	120.38	72.29
9.51	30.45	34.27	58.4	65.73
gesamt	76.59	29.99	178.78	70.01

**Foliation direction: perpendicular, pass: 4, spacing: 60 mm, penetration: 5.1 mm**

Sieve Size	Mass cubic	Percentage cubic	Mass non-cubic	Percentage non-cubic
mm	g	M-%	g	M-%
32	0	0.00	45.3	100.00
16	69.6	72.92	25.85	27.08
9.51	80.77	91.23	7.76	8.77
gesamt	150.37	65.58	78.91	34.42

**Foliation direction: perpendicular, pass: 5, spacing: 60 mm, penetration: 5.1 mm**

Sieve Size	Mass cubic	Percentage cubic	Mass non-cubic	Percentage non-cubic
mm	g	M-%	g	M-%
16	69.91	47.27	77.98	52.73
9.51	52.52	53.83	45.04	46.17
gesamt	122.43	49.88	123.02	50.12

**Foliation direction: perpendicular, pass: 6, spacing: 60 mm, penetration: 5.1 mm**

Sieve Size	Mass cubic	Percentage cubic	Mass non-cubic	Percentage non-cubic
mm	g	M-%	g	M-%
16	128.61	68.18	60.03	31.82
9.51	45.14	46.36	52.22	53.64
gesamt	173.75	60.75	112.25	39.25

**Foliation direction: perpendicular, pass: 7, spacing: 60 mm, penetration: 7.6 mm**

Sieve Size	Mass cubic	Percentage cubic	Mass non-cubic	Percentage non-cubic
mm	g	M-%	g	M-%
32	52.24	100.00	0	0.00
16	158.16	68.43	72.98	31.57
9.51	35.05	28.23	89.09	71.77
gesamt	245.45	60.23	162.07	39.77

**Foliation direction: perpendicular, pass: 8, spacing: 60 mm, penetration: 7.6 mm**

Sieve Size	Mass cubic	Percentage cubic	Mass non-cubic	Percentage non-cubic
mm	g	M-%	g	M-%
16	103.54	25.19	307.51	74.81
9.51	10	10.77	82.84	89.23
gesamt	113.54	22.53	390.35	77.47

**Foliation direction: perpendicular, pass: 9, spacing: 60 mm, penetration: 7.6 mm**

Sieve Size	Mass cubic	Percentage cubic	Mass non-cubic	Percentage non-cubic
mm	g	M-%	g	M-%
32	0	0.00	39.22	100.00
16	69.02	33.33	138.08	66.67
9.51	23.77	18.55	104.36	81.45
gesamt	92.79	24.78	281.66	75.22

**Foliation direction: perpendicular, pass: 10, spacing: 60 mm, penetration: 7.6 mm**

Sieve Size	Mass cubic	Percentage cubic	Mass non-cubic	Percentage non-cubic
mm	g	M-%	g	M-%
32	0	0.00	40.91	100.00
16	46.51	34.56	88.08	65.44
9.51	29.78	38.15	48.29	61.85
gesamt	76.29	30.09	177.28	69.91

**Foliation direction: perpendicular, pass: 13, spacing: 80 mm, penetration: 7.6 mm**

Sieve Size	Mass cubic	Percentage cubic	Mass non-cubic	Percentage non-cubic
mm	g	M-%	g	M-%
32	0	0.00	59.62	100.00
16	62.79	36.05	111.38	63.95
9.51	66.28	70.39	27.88	29.61
gesamt	129.07	39.36	198.88	60.64

**Foliation direction: perpendicular, pass: 14, spacing: 80 mm, penetration: 7.6 mm**

Sieve Size	Mass cubic	Percentage cubic	Mass non-cubic	Percentage non-cubic
mm	g	M-%	g	M-%
16	123.29	55.29	99.7	44.71
9.51	21.34	29.18	51.78	70.82
gesamt	144.63	48.84	151.48	51.16

**Foliation direction: perpendicular, pass: 15, spacing: 80 mm, penetration: 7.6 mm**

Sieve Size	Mass cubic	Percentage cubic	Mass non-cubic	Percentage non-cubic
mm	g	M-%	g	M-%
32	0	0.00	56.27	100.00
16	151.61	47.36	168.48	52.64
9.51	57.22	57.50	42.29	42.50
gesamt	208.83	43.88	267.04	56.12

**Foliation direction: perpendicular, pass: 16, spacing: 80 mm, penetration: 7.6 mm**

Sieve Size	Mass cubic	Percentage cubic	Mass non-cubic	Percentage non-cubic
mm	g	M-%	g	M-%
32	215.29	55.42	173.19	44.58
16	222.78	59.76	150.01	40.24
9.51	35.24	47.24	39.36	52.76
gesamt	473.31	56.62	362.56	43.38

**Foliation direction: perpendicular, pass: 19, spacing: 100 mm, penetration: 7.6 mm**

Sieve Size	Mass cubic	Percentage cubic	Mass non-cubic	Percentage non-cubic
mm	g	M-%	g	M-%
45	138.69	100.00	0	0.00
32	102.67	30.47	234.33	69.53
16	209.88	55.60	167.58	44.40
9.51	44.62	63.18	26	36.82
gesamt	495.86	53.68	427.91	46.32

**Foliation direction: perpendicular, pass: 20, spacing: 100 mm, penetration: 7.6 mm**

Sieve Size	Mass cubic	Percentage cubic	Mass non-cubic	Percentage non-cubic
mm	g	M-%	g	M-%
16	133.73	40.31	198.02	59.69

9.51	36.94	47.04	41.59	52.96
gesamt	170.67	41.60	239.61	58.40

**Foliation direction: perpendicular, pass: 21, spacing: 100 mm, penetration: 7.6 mm**

Sieve Size	Mass cubic	Percentage cubic	Mass non-cubic	Percentage non-cubic
mm	g	M-%	g	M-%
16	159.8	49.50	163.01	50.50
9.51	45.43	51.63	42.56	48.37
gesamt	205.23	49.96	205.57	50.04

**Foliation direction: perpendicular, pass: 22, spacing: 100 mm, penetration: 7.6 mm**

Sieve Size	Mass cubic	Percentage cubic	Mass non-cubic	Percentage non-cubic
mm	g	M-%	g	M-%
32	0.00	0.00	78.17	100.00
16	8.09	8.80	83.86	91.20
9.51	5.46	8.24	60.78	91.76
gesamt	13.55	5.73	222.81	94.27

**Foliation direction: oblique, pass: 3, spacing: 60 mm, penetration: 5.1 mm**

Sieve Size	Mass cubic	Percentage cubic	Mass non-cubic	Percentage non-cubic
mm	g	M-%	g	M-%
32	0.00	0.00	24.66	100.00
16	0.00	0.00	245.82	100.00
9.51	32.44	44.30	40.79	55.70
gesamt	32.44	9.44	311.27	90.56

**Foliation direction: oblique, pass: 4, spacing: 60 mm, penetration: 5.1 mm**

Sieve Size	Mass cubic	Percentage cubic	Mass non-cubic	Percentage non-cubic
mm	g	M-%	g	M-%
32	0	0.00	57.9	100.00
16	14.65	7.76	174.03	92.24
9.51	38.85	39.78	58.8	60.22
gesamt	53.5	15.54	290.73	84.46

**Foliation direction: oblique, pass: 5, spacing: 60 mm, penetration: 5.1 mm**

Sieve Size	Mass cubic	Percentage cubic	Mass non-cubic	Percentage non-cubic
mm	g	M-%	g	M-%
32	0	0.00	184.9	100.00
16	78.66	26.52	217.94	73.48
9.51	7.4	11.30	58.11	88.70
gesamt	86.06	15.73	460.95	84.27

**Foliation direction: oblique, pass: 6, spacing: 60 mm, penetration: 5.1 mm**

Sieve Size	Mass cubic	Percentage cubic	Mass non-cubic	Percentage non-cubic
mm	g	M-%	g	M-%
32	0	0.00	191.13	100.00
16	25.14	11.33	196.75	88.67
9.51	27.73	36.09	49.11	63.91
gesamt	52.87	10.79	436.99	89.21

**Foliation direction: oblique, pass: 7, spacing: 60 mm, penetration: 7.6 mm**



Sieve Size	Mass cubic	Percentage cubic	Mass non-cubic	Percentage non-cubic
mm	g	M-%	g	M-%
16	13.17	4.40	286.31	95.60
9.51	19.84	20.14	78.69	79.86
gesamt	33.01	8.29	365	91.71

**Foliation direction: oblique, pass: 8, spacing: 60 mm, penetration: 7.6 mm**

Sieve Size	Mass cubic	Percentage cubic	Mass non-cubic	Percentage non-cubic
mm	g	M-%	g	M-%
32	0	0.00	144.84	100.00
16	75.62	16.84	373.31	83.16
9.51	18.56	18.84	79.96	81.16
gesamt	94.18	13.60	598.11	86.40

**Foliation direction: oblique, pass: 9, spacing: 60 mm, penetration: 7.6 mm**

Sieve Size	Mass cubic	Percentage cubic	Mass non-cubic	Percentage non-cubic
mm	g	M-%	g	M-%
32	57.85	18.30	258.22	81.70
16	67.93	21.00	255.48	79.00
9.51	0	0.00	90.77	100.00
gesamt	125.78	17.22	604.47	82.78

**Foliation direction: oblique, pass: 10, spacing: 60 mm, penetration: 7.6 mm**

Sieve Size	Mass cubic	Percentage cubic	Mass non-cubic	Percentage non-cubic
mm	g	M-%	g	M-%
32	0	0.00	324.81	100.00
16	14.87	15.12	83.49	84.88
9.51	27.46	37.04	46.67	62.96
gesamt	42.33	8.51	454.97	91.49

**Foliation direction: oblique, pass: 13, spacing: 80 mm, penetration: 7.6 mm**

Sieve Size	Mass cubic	Percentage cubic	Mass non-cubic	Percentage non-cubic
mm	g	M-%	g	M-%
45	0	0.00	117.52	100.00
32	0	0.00	339.52	100.00
16	79.67	67.59	38.21	32.41
9.51	30.07	36.33	52.69	63.67
gesamt	109.74	16.69	547.94	83.31

**Foliation direction: oblique, pass: 14, spacing: 80 mm, penetration: 7.6 mm**

Sieve Size	Mass cubic	Percentage cubic	Mass non-cubic	Percentage non-cubic
mm	g	M-%	g	M-%
45	113.24	31.40	247.34	68.60
32	0	0.00	216.77	100.00
16	0	0.00	100.19	100.00
9.51	5.45	5.53	93.17	94.47
gesamt	118.69	15.29	657.47	84.71

**Foliation direction: oblique, pass: 15, spacing: 80 mm, penetration: 7.6 mm**

Sieve Size	Mass cubic	Percentage cubic	Mass non-cubic	Percentage non-cubic
mm	g	M-%	g	M-%
32	0	0.00	252.25	100.00
16	66.36	23.02	221.94	76.98
9.51	18.06	25.23	53.51	74.77
gesamt	84.42	13.79	527.7	86.21

**Foliation direction: oblique, pass: 16, spacing: 80 mm, penetration: 7.6 mm**

Sieve Size	Mass cubic	Percentage cubic	Mass non-cubic	Percentage non-cubic
mm	g	M-%	g	M-%
45	0	0.00	1260	100.00
32	63.18	21.39	232.24	78.61
16	61.67	26.10	174.59	73.90
9.51	14.11	23.65	45.56	76.35
gesamt	138.96	7.51	1712.39	92.49

**Foliation direction: oblique, pass: 19, spacing: 100 mm, penetration: 7.6 mm**

Sieve Size	Mass cubic	Percentage cubic	Mass non-cubic	Percentage non-cubic
mm	g	M-%	g	M-%
45	0.00	0.00	272.25	100.00
32	41.32	26.23	116.2	73.77
16	36	17.94	164.62	82.06
9.51	22.24	27.85	57.61	72.15
gesamt	99.56	14.02	610.68	85.98

**Foliation direction: oblique, pass: 20, spacing: 100 mm, penetration: 7.6 mm**

Sieve Size	Mass cubic	Percentage cubic	Mass non-cubic	Percentage non-cubic
mm	g	M-%	g	M-%
32	0	0.00	121.92	100.00
16	26.81	16.11	139.62	83.89
9.51	14.81	17.37	70.45	82.63
gesamt	41.62	11.14	331.99	88.86

**Foliation direction: oblique, pass: 21, spacing: 100 mm, penetration: 7.6 mm**

Sieve Size	Mass cubic	Percentage cubic	Mass non-cubic	Percentage non-cubic
mm	g	M-%	g	M-%
45	0	0.00	303.98	100.00
32	0	0.00	167.23	100.00
16	0	0.00	118.61	100.00
9.51	0	0.00	76.95	100.00
gesamt	0	0.00	666.77	100.00

**Foliation direction: oblique, pass: 22, spacing: 100 mm, penetration: 7.6 mm**

Sieve Size	Mass cubic	Percentage cubic	Mass non-cubic	Percentage non-cubic
mm	g	M-%	g	M-%
32	0.00	0.00	40.28	100.00
16	0.00	0.00	179.99	100.00
9.51	0.00	0.00	89.23	100.00
gesamt	0.00	0.00	309.50	100.00

**Foliation direction: massive, pass: 3, spacing: 60 mm, penetration: 5.1 mm**

Sieve Size	Mass cubic	Percentage cubic	Mass non-cubic	Percentage non-cubic
mm	g	M-%	g	M-%
45	0.00	0.00	193.10	100.00
32	0.00	0.00	125.07	100.00
16	0.00	0.00	278.57	100.00
9.51	5.27	5.74	86.57	94.26
gesamt	5.27	0.77	683.31	99.23

**Foliation direction: massive, pass: 4, spacing: 60 mm, penetration: 5.1 mm**

Sieve Size	Mass cubic	Percentage cubic	Mass non-cubic	Percentage non-cubic
mm	g	M-%	g	M-%
16	100.42	26.99	271.60	73.01
9.51	7.31	8.33	80.40	91.67
gesamt	107.73	23.43	352.00	76.57

**Foliation direction: massive, pass: 5, spacing: 60 mm, penetration: 5.1 mm**

Sieve Size	Mass cubic	Percentage cubic	Mass non-cubic	Percentage non-cubic
mm	g	M-%	g	M-%
32	0.00	0.00	140.94	100.00
16	26.04	17.63	121.70	82.37
9.51	3.96	5.03	74.83	94.97
gesamt	30.00	8.16	337.47	91.84

**Foliation direction: massive, pass: 6, spacing: 60 mm, penetration: 5.1 mm**

Sieve Size	Mass cubic	Percentage cubic	Mass non-cubic	Percentage non-cubic
mm	g	M-%	g	M-%
45	0.00	0.00	161.42	100.00
32	0.00	0.00	82.10	100.00
16	33.95	8.79	352.25	91.21
9.51	12.76	12.96	85.68	87.04
gesamt	46.71	6.41	681.45	93.59

**Foliation direction: massive, pass: 7, spacing: 60 mm, penetration: 7.6 mm**

Sieve Size	Mass cubic	Percentage cubic	Mass non-cubic	Percentage non-cubic
mm	g	M-%	g	M-%
32	0.00	0.00	178.43	100.00
16	20.74	7.25	265.18	92.75
9.51	6.56	6.19	99.47	93.81
gesamt	27.30	4.79	543.08	95.21

**Foliation direction: massive, pass: 8, spacing: 60 mm, penetration: 7.6 mm**

Sieve Size	Mass cubic	Percentage cubic	Mass non-cubic	Percentage non-cubic
mm	g	M-%	g	M-%
32	0.00	0.00	165.90	100.00
16	10.42	2.91	348.25	97.09
9.51	3.79	3.71	98.28	96.29
gesamt	14.21	2.27	612.43	97.73

**Foliation direction: massive, pass: 9, spacing: 60 mm, penetration: 7.6 mm**

Sieve Size	Mass cubic	Percentage cubic	Mass non-cubic	Percentage non-cubic
mm	g	M-%	g	M-%
32	0.00	0.00	119.93	100.00
16	36.42	12.06	265.47	87.94
9.51	10.62	10.41	91.41	89.59
gesamt	47.04	8.98	476.81	91.02

**Foliation direction: massive, pass: 10, spacing: 60 mm, penetration: 7.6 mm**

Sieve Size	Mass cubic	Percentage cubic	Mass non-cubic	Percentage non-cubic
mm	g	M-%	g	M-%
32	0.00	0.00	232.67	100.00
16	12.71	3.85	317.42	96.15
9.51	26.79	29.86	62.92	70.14
gesamt	39.50	6.05	613.01	93.95

**Foliation direction: massive, pass: 13, spacing: 80 mm, penetration: 7.6 mm**

Sieve Size	Mass cubic	Percentage cubic	Mass non-cubic	Percentage non-cubic
mm	g	M-%	g	M-%
45	0.00	0.00	209.50	100.00
32	80.07	60.98	51.24	39.02
16	161.12	40.13	240.38	59.87
9.51	13.64	14.90	77.89	85.10
gesamt	254.83	30.56	579.01	69.44

**Foliation direction: massive, pass: 14, spacing: 80 mm, penetration: 7.6 mm**

Sieve Size	Mass cubic	Percentage cubic	Mass non-cubic	Percentage non-cubic
mm	g	M-%	g	M-%
32	0.00	0.00	61.20	100.00
16	76.77	24.00	243.17	76.00
9.51	41.27	47.28	46.01	52.72
gesamt	118.04	25.20	350.38	74.80

**Foliation direction: massive, pass: 15, spacing: 80 mm, penetration: 7.6 mm**

Sieve Size	Mass cubic	Percentage cubic	Mass non-cubic	Percentage non-cubic
mm	g	M-%	g	M-%
45	0.00	0.00	570.81	100.00
16	76.45	25.75	220.47	74.25
9.51	29.66	36.25	52.17	63.75
gesamt	106.11	11.17	843.45	88.83

**Foliation direction: massive, pass: 16, spacing: 80 mm, penetration: 7.6 mm**

Sieve Size	Mass cubic	Percentage cubic	Mass non-cubic	Percentage non-cubic
mm	g	M-%	g	M-%
16	33.21	17.67	154.69	82.33
9.51	31.82	31.79	68.28	68.21
gesamt	65.03	22.58	222.97	77.42

**Foliation direction: massive, pass: 17, spacing: 80 mm, penetration: 7.6 mm**

Sieve Size	Mass cubic	Percentage cubic	Mass non-cubic	Percentage non-cubic
mm	g	M-%	g	M-%
45	163.33	17.15	788.79	82.85
16	112.50	46.47	129.57	53.53
9.51	25.88	30.66	58.53	69.34
gesamt	301.71	23.60	976.89	76.40

**Foliation direction: massive, pass: 20, spacing: 100 mm, penetration: 7.6 mm**

Sieve Size	Mass cubic	Percentage cubic	Mass non-cubic	Percentage non-cubic
mm	g	M-%	g	M-%
45	0.00	0.00	1075.80	100.00
32	49.44	13.07	328.74	86.93
16	99.70	44.50	124.34	55.50
9.51	51.56	60.70	33.38	39.30
gesamt	200.70	11.38	1562.26	88.62

**Foliation direction: massive, pass: 21, spacing: 100 mm, penetration: 7.6 mm**

## Augen Gneiss

Sieve Size	Mass cubic	Percentage cubic	Mass non-cubic	Percentage non-cubic
mm	g	M-%	g	M-%
45	0	0.00	129.15	100.00
32	41.56	14.76	240.02	85.24
16	79.75	30.45	182.18	69.55
9.51	41.98	50.17	41.69	49.83
gesamt	163.29	21.59	593.04	78.41

**Foliation direction: parallel, pass: 3, spacing: 60 mm, penetration: 5.1 mm**

Sieve Size	Mass cubic	Percentage cubic	Mass non-cubic	Percentage non-cubic
mm	g	M-%	g	M-%
32	0.00	0.00	238.83	100.00
16	46.90	18.90	201.19	81.10
9.51	8.82	17.45	41.73	82.55
gesamt	55.72	10.37	481.75	89.63

**Foliation direction: parallel, pass: 4, spacing: 60 mm, penetration: 5.1 mm**

Sieve Size	Mass cubic	Percentage cubic	Mass non-cubic	Percentage non-cubic
mm	g	M-%	g	M-%
16	109.77	37.11	186.05	62.89
9.51	16.81	18.93	72.00	81.07
gesamt	126.58	32.91	258.05	67.09

**Foliation direction: parallel, pass: 5, spacing: 60 mm, penetration: 5.1 mm**

Sieve Size	Mass cubic	Percentage cubic	Mass non-cubic	Percentage non-cubic
mm	g	M-%	g	M-%
32	0.00	0.00	65.21	100.00
16	54.02	22.38	187.33	77.62
9.51	37.10	58.78	26.02	41.22
gesamt	91.12	24.65	278.56	75.35

**Foliation direction: parallel, pass: 6, spacing: 60 mm, penetration: 5.1 mm**

Sieve Size	Mass cubic	Percentage cubic	Mass non-cubic	Percentage non-cubic
mm	g	M-%	g	M-%
32	43.07	15.03	243.52	84.97
16	9.08	3.82	228.58	96.18
9.51	26.25	34.78	49.22	65.22
gesamt	78.40	13.07	521.32	86.93

**Foliation direction: parallel, pass: 7, spacing: 60 mm, penetration: 7.6 mm**

Sieve Size	Mass cubic	Percentage cubic	Mass non-cubic	Percentage non-cubic
mm	g	M-%	g	M-%
16	0.00	0.00	261.85	100.00
9.51	5.39	7.93	62.57	92.07
gesamt	5.39	1.63	324.42	98.37

**Foliation direction: parallel, pass: 8, spacing: 60 mm, penetration: 7.6 mm**

Sieve Size	Mass cubic	Percentage cubic	Mass non-cubic	Percentage non-cubic
mm	g	M-%	g	M-%
32	0.00	0.00	177.36	100.00
16	178.18	53.33	155.93	46.67
9.51	17.65	20.55	68.23	79.45
gesamt	195.83	32.78	401.52	67.22

**Foliation direction: parallel, pass: 9, spacing: 60 mm, penetration: 7.6 mm**

Sieve Size	Mass cubic	Percentage cubic	Mass non-cubic	Percentage non-cubic
mm	g	M-%	g	M-%
32	0.00	0.00	53.46	100.00
16	107.17	29.14	260.63	70.86
9.51	12.44	17.48	58.74	82.52
gesamt	119.61	24.29	372.83	75.71

**Foliation direction: parallel, pass: 10, spacing: 60 mm, penetration: 7.6 mm**

Sieve Size	Mass cubic	Percentage cubic	Mass non-cubic	Percentage non-cubic
mm	g	M-%	g	M-%
32		0.00	165.32	100.00
16	37.25	33.91	72.59	66.09
9.51	12.09	19.77	49.05	80.23
gesamt	49.34	14.67	286.96	85.33

**Foliation direction: parallel, pass: 13, spacing: 80 mm, penetration: 7.6 mm**

Sieve Size	Mass cubic	Percentage cubic	Mass non-cubic	Percentage non-cubic
mm	g	M-%	g	M-%
45	0.00	0.00	116.49	100.00
32	0.00	0.00	43.77	100.00
16	0.00	0.00	146.52	100.00
9.51	10.62	14.73	61.47	85.27
gesamt	10.62	2.80	368.25	97.20

**Foliation direction: parallel, pass: 14, spacing: 80 mm, penetration: 7.6 mm**

Sieve Size	Mass cubic	Percentage cubic	Mass non-cubic	Percentage non-cubic
mm	g	M-%	g	M-%
45	0.00	0.00	85.91	100.00
32		0.00	175.79	100.00
16	56.43	27.14	151.48	72.86
9.51	18.57	22.74	63.11	77.26
gesamt	75.00	13.60	476.29	86.40

**Foliation direction: parallel, pass: 15, spacing: 80 mm, penetration: 7.6 mm**

Sieve Size	Mass cubic	Percentage cubic	Mass non-cubic	Percentage non-cubic
mm	g	M-%	g	M-%
32	0.00	0.00	113.46	100.00
16	48.31	34.58	91.38	65.42
9.51	5.12	9.28	50.06	90.72
gesamt	53.43	17.33	254.90	82.67

**Foliation direction: parallel, pass: 16, spacing: 80 mm, penetration: 7.6 mm**

Sieve Size	Mass cubic	Percentage cubic	Mass non-cubic	Percentage non-cubic
mm	g	M-%	g	M-%
45	0.00	0.00	212.72	100.00
32	106.15	34.29	203.40	65.71
16	161.54	32.35	337.80	67.65
9.51	13.93	22.50	47.98	77.50
gesamt	281.62	25.99	801.90	74.01

**Foliation direction: parallel, pass: 19, spacing: 100 mm, penetration: 7.6 mm**

Sieve Size	Mass cubic	Percentage cubic	Mass non-cubic	Percentage non-cubic
mm	g	M-%	g	M-%
45	250.76	59.29	172.21	40.71
32	0.00	0.00	180.06	100.00
16	78.18	29.79	184.29	70.21
9.51	26.23	40.63	38.33	59.37
gesamt	355.17	38.19	574.89	61.81

**Foliation direction: parallel, pass: 20, spacing: 100 mm, penetration: 7.6 mm**

Sieve Size	Mass cubic	Percentage cubic	Mass non-cubic	Percentage non-cubic
mm	g	M-%	g	M-%
45	0.00	0.00	274.19	100.00
32	0.00	0.00	121.38	100.00
16	0.00	0.00	102.17	100.00
9.51	15.97	22.91	53.75	77.09
gesamt	15.97	2.81	551.49	97.19

**Foliation direction: parallel, pass: 21, spacing: 100 mm, penetration: 7.6 mm**

Sieve Size	Mass cubic	Percentage cubic	Mass non-cubic	Percentage non-cubic
mm	g	M-%	g	M-%
45	0.00	0.00	150.36	100.00
32	0.00	0.00	204.98	100.00
16	39.68	26.94	107.62	73.06
9.51	9.72	20.96	36.66	79.04
gesamt	49.40	9.00	499.62	91.00

**Foliation direction: parallel, pass: 22, spacing: 100 mm, penetration: 7.6 mm**

Sieve Size	Mass cubic	Percentage cubic	Mass non-cubic	Percentage non-cubic
mm	g	M-%	g	M-%
32.00	0.00	0.00	276.52	100.00
16.00	23.29	8.63	246.72	91.37
9.51	8.19	11.41	63.58	88.59
gesamt	31.48	5.09	586.82	94.91

**Foliation direction: perpendicular, pass: 3, spacing: 60 mm, penetration: 5.1 mm**

Sieve Size	Mass cubic	Percentage cubic	Mass non-cubic	Percentage non-cubic
mm	g	M-%	g	M-%
32.00	0.00	0.00	39.87	100.00
16.00	72.64	28.01	186.73	71.99
9.51	4.53	7.92	52.65	92.08
gesamt	77.17	21.65	279.25	78.35

**Foliation direction: perpendicular, pass: 4, spacing: 60 mm, penetration: 5.1 mm**

Sieve Size	Mass cubic	Percentage cubic	Mass non-cubic	Percentage non-cubic
mm	g	M-%	g	M-%
32.00	0.00	0.00	78.24	100.00
16.00	71.32	36.77	122.64	63.23
9.51	35.53	41.80	49.47	58.20
gesamt	106.85	29.91	250.35	70.09

**Foliation direction: perpendicular, pass: 5, spacing: 60 mm, penetration: 5.1 mm**

Sieve Size	Mass cubic	Percentage cubic	Mass non-cubic	Percentage non-cubic
mm	g	M-%	g	M-%
16.00	62.49	27.11	167.98	72.89
9.51	30.49	35.34	55.79	64.66
gesamt	92.98	29.35	223.77	70.65

**Foliation direction: perpendicular, pass: 6, spacing: 60 mm, penetration: 5.1 mm**

Sieve Size	Mass cubic	Percentage cubic	Mass non-cubic	Percentage non-cubic
mm	g	M-%	g	M-%
32.00	104.18	100.00	0.00	0.00
16.00	115.49	39.35	177.97	60.65
9.51	36.00	40.46	52.97	59.54
gesamt	255.67	52.54	230.94	47.46

**Foliation direction: perpendicular, pass: 7, spacing: 60 mm, penetration: 7.6 mm**

Sieve Size	Mass cubic	Percentage cubic	Mass non-cubic	Percentage non-cubic
mm	g	M-%	g	M-%
16.00	103.86	35.38	189.72	64.62
9.51	33.84	41.50	47.71	58.50
gesamt	137.70	36.71	237.43	63.29

**Foliation direction: perpendicular, pass: 8, spacing: 60 mm, penetration: 7.6 mm**



Sieve Size	Mass cubic	Percentage cubic	Mass non-cubic	Percentage non-cubic
mm	g	M-%	g	M-%
32.00	0.00	0.00	32.94	100.00
16.00	68.25	24.15	214.32	75.85
9.51	11.55	15.14	64.75	84.86
gesamt	79.80	20.37	312.01	79.63

**Foliation direction: perpendicular, pass: 9, spacing: 60 mm, penetration: 7.6 mm**

Sieve Size	Mass cubic	Percentage cubic	Mass non-cubic	Percentage non-cubic
mm	g	M-%	g	M-%
32.00	0.00	0.00	120.38	100.00
16.00	106.46	34.45	202.61	65.55
9.51	24.87	30.69	56.16	69.31
gesamt	131.33	25.73	379.15	74.27

**Foliation direction: perpendicular, pass: 10, spacing: 60 mm, penetration: 7.6 mm**

Sieve Size	Mass cubic	Percentage cubic	Mass non-cubic	Percentage non-cubic
mm	g	M-%	g	M-%
45.00	0.00	0.00	88.67	100.00
32.00	0.00	0.00	142.94	100.00
16.00	16.10	12.83	109.41	87.17
9.51	25.13	27.84	65.15	72.16
gesamt	41.23	9.22	406.17	90.78

**Foliation direction: perpendicular, pass: 13, spacing: 80 mm, penetration: 7.6 mm**

Sieve Size	Mass cubic	Percentage cubic	Mass non-cubic	Percentage non-cubic
mm	g	M-%	g	M-%
32.00	0.00	0.00	67.77	100.00
16.00	99.49	35.83	178.18	64.17
9.51	25.27	32.31	52.94	67.69
gesamt	124.76	29.45	298.89	70.55

**Foliation direction: perpendicular, pass: 14, spacing: 80 mm, penetration: 7.6 mm**

Sieve Size	Mass cubic	Percentage cubic	Mass non-cubic	Percentage non-cubic
mm	g	M-%	g	M-%
32.00	66.31	68.54	30.44	31.46
16.00	17.82	33.60	35.22	66.40
9.51	14.28	20.64	54.89	79.36
gesamt	98.41	44.94	120.55	55.06

**Foliation direction: perpendicular, pass: 15, spacing: 80 mm, penetration: 7.6 mm**

Sieve Size	Mass cubic	Percentage cubic	Mass non-cubic	Percentage non-cubic
mm	g	M-%	g	M-%
45.00	0.00	0.00	85.35	100.00
32.00	72.62	29.30	175.27	70.70
16.00	77.46	25.68	224.17	74.32
9.51	21.46	25.81	61.67	74.19
gesamt	171.54	23.89	546.46	76.11

**Foliation direction: perpendicular, pass: 16, spacing: 80 mm, penetration: 7.6 mm**

Sieve Size	Mass cubic	Percentage cubic	Mass non-cubic	Percentage non-cubic
mm	g	M-%	g	M-%
32.00	69.25	56.79	52.68	43.21
16.00	63.76	22.06	225.26	77.94
9.51	33.73	46.35	39.04	53.65
gesamt	166.74	34.47	316.98	65.53

**Foliation direction: perpendicular, pass: 19, spacing: 100 mm, penetration: 7.6 mm**

Sieve Size	Mass cubic	Percentage cubic	Mass non-cubic	Percentage non-cubic
mm	g	M-%	g	M-%
45.00	0.00	0.00	743.00	100.00
32.00	0.00	0.00	47.09	100.00
16.00	138.57	46.79	157.58	53.21
9.51	33.47	49.29	34.43	50.71
gesamt	172.04	14.91	982.10	85.09

**Foliation direction: perpendicular, pass: 20, spacing: 100 mm, penetration: 7.6 mm**

Sieve Size	Mass cubic	Percentage cubic	Mass non-cubic	Percentage non-cubic
mm	g	M-%	g	M-%
45.00	211.02	70.69	87.48	29.31
32.00	0.00	0.00	172.35	100.00
16.00	103.79	31.79	222.73	68.21
9.51	18.10	23.14	60.11	76.86
gesamt	332.91	38.02	542.67	61.98

**Foliation direction: perpendicular, pass: 21, spacing: 100 mm, penetration: 7.6 mm**

Sieve Size	Mass cubic	Percentage cubic	Mass non-cubic	Percentage non-cubic
mm	g	M-%	g	M-%
45.00	0.00	0.00	105.49	100.00
32.00	43.59	17.71	202.61	82.29
16.00	112.17	41.75	156.49	58.25
9.51	13.69	19.69	55.83	80.31
gesamt	169.45	24.56	520.42	75.44

**Foliation direction: perpendicular, pass: 22, spacing: 100 mm, penetration: 7.6 mm**

Sieve Size	Mass cubic	Percentage cubic	Mass non-cubic	Percentage non-cubic
mm	g	M-%	g	M-%
16	100.49	55.40	80.89	44.60
9.51	8.70	11.54	66.68	88.46
gesamt	109.19	42.53	147.57	57.47

**Foliation direction: oblique, pass: 3, spacing: 60 mm, penetration: 5.1 mm**

Sieve Size	Mass cubic	Percentage cubic	Mass non-cubic	Percentage non-cubic
mm	g	M-%	g	M-%
32	0.00	0.00	43.56	100.00
16	33.57	21.85	120.06	78.15
9.51	22.27	33.59	44.03	66.41
gesamt	55.84	21.19	207.65	78.81

**Foliation direction: oblique, pass: 4, spacing: 60 mm, penetration: 5.1 mm**

Sieve Size	Mass cubic	Percentage cubic	Mass non-cubic	Percentage non-cubic
mm	g	M-%	g	M-%
32	0.00	0.00	31.69	100.00
16	81.40	28.55	203.69	71.45
9.51	54.19	64.27	30.12	35.73
gesamt	135.59	33.81	265.50	66.19

**Foliation direction: oblique, pass: 5, spacing: 60 mm, penetration: 5.1 mm**

Sieve Size	Mass cubic	Percentage cubic	Mass non-cubic	Percentage non-cubic
mm	g	M-%	g	M-%
32	50.02	50.62	48.79	49.38
16	6.10	2.64	224.68	97.36
9.51	22.80	30.32	52.39	69.68
gesamt	78.92	19.50	325.86	80.50

**Foliation direction: oblique, pass: 6, spacing: 60 mm, penetration: 5.1 mm**

Sieve Size	Mass cubic	Percentage cubic	Mass non-cubic	Percentage non-cubic
mm	g	M-%	g	M-%
32	0.00	0.00	305.84	100.00
16	113.86	38.93	178.60	61.07
9.51	9.71	11.39	75.54	88.61
gesamt	123.57	18.08	559.98	81.92

**Foliation direction: oblique, pass: 7, spacing: 60 mm, penetration: 7.6 mm**

Sieve Size	Mass cubic	Percentage cubic	Mass non-cubic	Percentage non-cubic
mm	g	M-%	g	M-%
16	140.27	72.19	54.03	27.81
9.51	30.85	45.71	36.64	54.29
gesamt	171.12	65.37	90.67	34.63

**Foliation direction: oblique, pass: 8, spacing: 60 mm, penetration: 7.6 mm**

Sieve Size	Mass cubic	Percentage cubic	Mass non-cubic	Percentage non-cubic
mm	g	M-%	g	M-%
32	0.00	0.00	55.97	100.00
16	48.35	15.88	256.04	84.12
9.51	28.67	29.09	69.87	70.91
gesamt	77.02	16.78	381.88	83.22

**Foliation direction: oblique, pass: 9, spacing: 60 mm, penetration: 7.6 mm**

Sieve Size	Mass cubic	Percentage cubic	Mass non-cubic	Percentage non-cubic
mm	g	M-%	g	M-%
32	0.00	0.00	130.43	100.00
16	74.05	21.21	275.16	78.79
9.51	29.82	33.15	60.13	66.85
gesamt	103.87	18.24	465.72	81.76

**Foliation direction: oblique, pass: 10, spacing: 60 mm, penetration: 7.6 mm**

Sieve Size	Mass cubic	Percentage cubic	Mass non-cubic	Percentage non-cubic
mm	g	M-%	g	M-%
45	0.00	0.00	147.05	100.00
16	80.52	28.06	206.41	71.94
9.51	34.02	35.27	62.44	64.73
gesamt	114.54	21.59	415.90	78.41

**Foliation direction: oblique, pass: 13, spacing: 80 mm, penetration: 7.6 mm**

Sieve Size	Mass cubic	Percentage cubic	Mass non-cubic	Percentage non-cubic
mm	g	M-%	g	M-%
45	310.04	100.00	0.00	0.00
32	0.00	0.00	119.87	100.00
16	62.95	42.38	85.57	57.62
9.51	26.46	33.28	53.04	66.72
gesamt	399.45	60.71	258.48	39.29

**Foliation direction: oblique, pass: 14, spacing: 80 mm, penetration: 7.6 mm**

Sieve Size	Mass cubic	Percentage cubic	Mass non-cubic	Percentage non-cubic
mm	g	M-%	g	M-%
32	188.39	67.15	92.15	32.85
16	270.19	77.78	77.20	22.22
9.51	36.45	42.85	48.61	57.15
gesamt	495.03	69.43	217.96	30.57

**Foliation direction: oblique, pass: 15, spacing: 80 mm, penetration: 7.6 mm**

Sieve Size	Mass cubic	Percentage cubic	Mass non-cubic	Percentage non-cubic
mm	g	M-%	g	M-%
45	0.00	0.00	150.77	100.00
32	76.12	100.00	0.00	0.00
16	0.00	0.00	101.59	100.00
9.51	16.48	28.86	40.63	71.14
gesamt	92.60	24.02	292.99	75.98

**Foliation direction: oblique, pass: 16, spacing: 80 mm, penetration: 7.6 mm**

Sieve Size	Mass cubic	Percentage cubic	Mass non-cubic	Percentage non-cubic
mm	g	M-%	g	M-%
45	0.00	0.00	311.10	100.00
32	150.46	100.00	0.00	0.00
16	101.98	30.82	228.92	69.18
9.51	59.97	66.51	30.20	33.49
gesamt	312.41	35.40	570.22	64.60

**Foliation direction: oblique, pass: 19, spacing: 100 mm, penetration: 7.6 mm**

Sieve Size	Mass cubic	Percentage cubic	Mass non-cubic	Percentage non-cubic
mm	g	M-%	g	M-%
45	0.00	0.00	779.11	100.00
32	0.00	0.00	70.96	100.00
16	36.84	17.34	175.65	82.66
9.51	4.55	6.33	67.33	93.67
gesamt	41.39	3.65	1093.05	96.35

**Foliation direction: oblique, pass: 20, spacing: 100 mm, penetration: 7.6 mm**

Sieve Size	Mass cubic	Percentage cubic	Mass non-cubic	Percentage non-cubic
mm	g	M-%	g	M-%
32	0.00	0.00	282.59	100.00
16	10.16	3.98	245.31	96.02
9.51	18.56	29.01	45.42	70.99
gesamt	28.72	4.77	573.32	95.23

**Foliation direction: oblique, pass: 21, spacing: 100 mm, penetration: 7.6 mm**

Sieve Size	Mass cubic	Percentage cubic	Mass non-cubic	Percentage non-cubic
mm	g	M-%	g	M-%
45	78.86	23.08	262.86	76.92
32	61.87	38.05	100.74	61.95
16	71.98	18.37	319.81	81.63
9.51	18.55	26.01	52.77	73.99
gesamt	231.26	23.90	736.18	76.10

**Foliation direction: oblique, pass: 22, spacing: 100 mm, penetration: 7.6 mm**

## Schistose Gneiss

Sieve Size	Mass cubic	Percentage cubic	Mass non-cubic	Percentage non-cubic
mm	g	M-%	g	M-%
16	28.81	11.76	216.14	88.24
9.51	12.69	15.87	67.28	84.13
gesamt	41.50	12.77	283.42	87.23

**Foliation direction: oblique, pass: 3, spacing: 60 mm, penetration: 5.1 mm**

Sieve Size	Mass cubic	Percentage cubic	Mass non-cubic	Percentage non-cubic
mm	g	M-%	g	M-%
32	0.00	0.00	86.84	100.00
16	36.41	14.41	216.26	85.59
9.51	23.72	29.15	57.65	70.85
gesamt	60.13	14.29	360.75	85.71

**Foliation direction: oblique, pass: 4, spacing: 60 mm, penetration: 5.1 mm**

Sieve Size	Mass cubic	Percentage cubic	Mass non-cubic	Percentage non-cubic
mm	g	M-%	g	M-%
32	54.19	28.63	135.10	71.37
16	63.49	20.99	238.93	79.01
9.51	16.46	21.68	59.48	78.32
gesamt	134.14	23.63	433.51	76.37

**Foliation direction: oblique, pass: 5, spacing: 60 mm, penetration: 5.1 mm**

Sieve Size	Mass cubic	Percentage cubic	Mass non-cubic	Percentage non-cubic
mm	g	M-%	g	M-%
32	0.00	0.00	72.81	100.00
16	69.66	28.31	176.39	71.69
9.51	22.32	26.92	60.60	73.08
gesamt	91.98	22.89	309.80	77.11

**Foliation direction: oblique, pass: 6, spacing: 60 mm, penetration: 5.1 mm**

Sieve Size	Mass cubic	Mass-% cubic	Mass non-cubic	Mass-% non-cubic
mm	g	M-%	g	M-%
32	0.00	0.00	286.60	100.00
16	70.98	17.80	327.81	82.20
9.51	36.33	41.85	50.49	58.15
gesamt	107.31	13.90	664.90	86.10

**Foliation direction: oblique, pass: 7, spacing: 60 mm, penetration: 7.6 mm**

Sieve Size	Mass cubic	Mass-% cubic	Mass non-cubic	Mass-% non-cubic
mm	g	M-%	g	M-%
32	83.27	30.15	192.96	69.85
16	84.42	18.61	369.21	81.39
9.51	29.74	29.45	71.25	70.55
gesamt	197.43	23.76	633.42	76.24

**Foliation direction: oblique, pass: 8, spacing: 60 mm, penetration: 7.6 mm**

Sieve Size	Mass cubic	Mass-% cubic	Mass non-cubic	Mass-% non-cubic
mm	g	M-%	g	M-%
45	0.00	0.00	598.24	100.00
32	0.00	0.00	179.35	100.00
16	87.58	22.59	300.19	77.41
9.51	41.87	43.86	53.59	56.14
gesamt	129.45	10.27	1131.37	89.73

**Foliation direction: oblique, pass: 9, spacing: 60 mm, penetration: 7.6 mm**

Sieve Size	Mass cubic	Mass-% cubic	Mass non-cubic	Mass-% non-cubic
mm	g	M-%	g	M-%
32	106.83	41.51	150.51	58.49
16	153.54	37.29	258.24	62.71
9.51	33.25	32.06	70.46	67.94
gesamt	293.62	37.99	479.21	62.01

**Foliation direction: oblique, pass: 10, spacing: 60 mm, penetration: 7.6 mm**

Sieve Size	Mass cubic	Mass-% cubic	Mass non-cubic	Mass-% non-cubic
mm	g	M-%	g	M-%
45	0.00	0.00	214.81	100.00
32	112.11	67.03	55.14	32.97
16	101.41	30.62	229.78	69.38
9.51	47.41	57.15	35.54	42.85
gesamt	260.93	32.77	535.27	67.23

**Foliation direction: oblique, pass: 13, spacing: 80 mm, penetration: 7.6 mm**

Sieve Size	Mass cubic	Mass-% cubic	Mass non-cubic	Mass-% non-cubic
mm	g	M-%	g	M-%
45	0.00	0.00	129.58	100.00
32	50.47	33.08	102.09	66.92
16	115.97	49.17	119.89	50.83
9.51	50.03	61.15	31.79	38.85
gesamt	216.47	36.09	383.35	63.91

**Foliation direction: oblique, pass: 14, spacing: 80 mm, penetration: 7.6 mm**

## Appendix B- Aspect Ratios

---

Sieve Size	Mass cubic	Mass-% cubic	Mass non-cubic	Mass-% non-cubic
mm	g	M-%	g	M-%
45	0.00	0.00	525.11	100.00
32	58.58	100.00	0.00	0.00
16	53.94	36.62	93.34	63.38
9.51	41.03	40.98	59.10	59.02
gesamt	153.55	18.48	677.55	81.52

**Foliation direction: oblique, pass: 15, spacing: 80 mm, penetration: 7.6 mm**

Sieve Size	Mass cubic	Mass-% cubic	Mass non-cubic	Mass-% non-cubic
mm	g	M-%	g	M-%
45	125.43	37.78	206.55	62.22
16	274.67	71.92	107.25	28.08
9.51	31.49	36.68	54.37	63.32
gesamt	431.59	53.96	368.17	46.04

**Foliation direction: oblique, pass: 16, spacing: 80 mm, penetration: 7.6 mm**

Sieve Size	Mass cubic	Mass-% cubic	Mass non-cubic	Mass-% non-cubic
mm	g	M-%	g	M-%
45	0.00	0.00	372.95	100.00
32	0.00	0.00	66.14	100.00
16	11.83	29.33	28.50	70.67
9.51	27.69	39.82	41.84	60.18
gesamt	39.52	7.20	509.43	92.80

**Foliation direction: oblique, pass: 17, spacing: 80 mm, penetration: 7.6 mm**

Sieve Size	Mass cubic	Mass-% cubic	Mass non-cubic	Mass-% non-cubic
mm	g	M-%	g	M-%
45	0.00	0.00	486.69	100.00
16	71.42	40.56	104.66	59.44
9.51	33.79	44.42	42.28	55.58
gesamt	105.21	14.24	633.63	85.76

**Foliation direction: oblique, pass: 20, spacing: 100 mm, penetration: 7.6 mm**

Sieve Size	Mass cubic	Mass-% cubic	Mass non-cubic	Mass-% non-cubic
mm	g	M-%	g	M-%
45	598.51	69.54	262.16	30.46
32	241.30	46.06	282.55	53.94
16	293.38	68.88	132.55	31.12
9.51	74.16	79.87	18.69	20.13
gesamt	1207.35	63.43	695.95	36.57

**Foliation direction: oblique, pass: 21, spacing: 100 mm, penetration: 7.6 mm**